

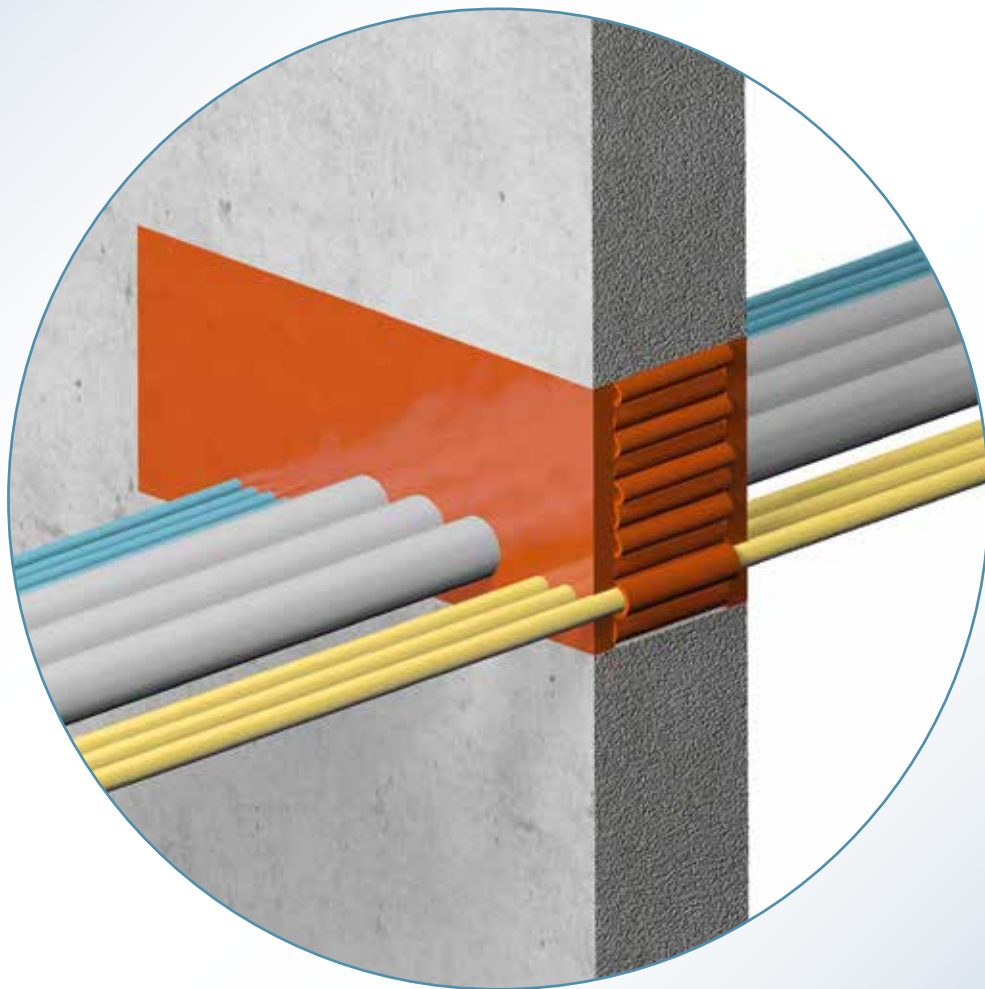

# INSTALLATION INSTRUCTIONS NOFIRNO<sup>®</sup> SEALING SYSTEM (NOFIRNO<sup>®</sup> SLEEVES/SEALANT) FOR (MULTI-) CABLE TRANSITS



**NO FIRNO<sup>®</sup>**



# SEALING VALLEY

KNOWLEDGE TRANSFER, EDUCATION AND TRAINING

Beele campus 45.000 m<sup>2</sup>  
Ready 2020/2021



- A: Reception, Education Center, Workshops, Video Conferences
- B: Demonstration, Training and Installation
- C: R&D center, Testing Facilities
- D: Pilot plant for new developments
- E: Production Plant phase 1 and 2
- F: Park with amphitheater and food forest 15.000 m<sup>2</sup>

<b>Copyright</b>	: BEELE Engineering BV, Aalten, the Netherlands. Proprietary rights on all drawings and technical data released in this brochure. © 1997-2022
<b>Edition</b>	: January 2022
<b>Note</b>	: No part of this publication may be reproduced without explicit written approval of BEELE Engineering BV.
<b>Research &amp; Development</b>	: BEELE Engineering BV, Aalten, the Netherlands.
<b>Note</b>	: The manufacturer reserves the right to make dimensional and design modifications without prior notification.
©	: ACTIFOAM, AQUASTOP, BEEBLOCK, BEELE, BEELE WE CARE, BEESEAL, CET-A-SIL, CONDUCTION, CONTROLFIL, CRUSHER, CSD, DYNATITE, FIRAQUA, FIRSTO, FISSIC, FIWA, FYLLOFYS, FYLLOFOAM, GLANDMOD, LEAXEAL, NOFIRNO, RISE, SEALING VALLEY, S, SLIPSIL, Ranges SLIPSIL plugs are registered trade marks of BEELE Engineering.
<b>brochure code</b>	: installation NOFIRNO cable/construction

## INSTALLATION INSTRUCTIONS FOR NOFIRNO® MULTI-CABLE TRANSIT SEALING SYSTEM



Not only for standard cellulose fires, but also for applications with highest fire and tightness ratings (up to HC and Jet Fires) the NOFIRNO® sealing system is used. The NOFIRNO® multi-cable transit sealing system is composed of NOFIRNO® insert (cable) sleeves in 29 different sizes, NOFIRNO® (multi-) filler sleeves in 5 different sizes and NOFIRNO® sealant.

The use of NOFIRNO® multi-filler sleeves contributes to ease of installation.

## INSTALLATION INSTRUCTIONS FOR NOFIRNO® MULTI-CABLE TRANSIT SEALING SYSTEM

### PRODUCT INFORMATION SEALANT

01) colour	red brown
02) specific gravity	1.40 ± 0.03 g/cm <sup>3</sup>
03) curing of top layer	0.5 - 1 hour depending on temperature and air humidity
04) service temperature	-50 °C up to +180 °C
05) tensile strength	1.5 MPa
06) elongation at break	200%
07) hardness	45 Shore A
08) elastic deformation	approx. 50%
09) resistance	UV, Ozone, arctic conditions
10) ageing	more than 20 years
11) supplied in	310 ml cartridges
12) storage	to be stored cool and dry min/max temperature = +5/+30° C
13) storage life	guaranteed 6 months; when applied later than 6 months after date of manufacturing, curing and adhesive properties have to be checked before application

article number 50.0107



*NOFIRNO® is absolutely HALOGEN FREE with zero VOC (volatiles organic compounds) according to TÜV report 89206405-01. Furthermore NOFIRNO® has a low smoke index and a high oxygen index (ISO 4589-2: 1996), and low flame spread characteristics according to IMO Resolution A.653(16). NOFIRNO® is a paste-like compound which is simple to use. NOFIRNO® has a balanced viscosity and can be applied overhead.*

blue



article number 50.0108

black



article number 50.0109

white



article number 50.0110

grey



article number 50.0111

## INSTALLATION INSTRUCTIONS FOR NOFIRNO® MULTI-CABLE TRANSIT SEALING SYSTEM

### NOFIRNO® CABLE INSERT SLEEVES



NOFIRNO® cable insert sleeves are used to separate cables inside the conduit opening. This allows for ease of application of the NOFIRNO® sealant in between and around the ducted cables.

The NOFIRNO® cable sleeves are available in 29 sizes and in lengths of 60, 80, 110, 130, 140, 160 and 210 mm. The NOFIRNO® cable insert sleeves are split lengthwise and can therefore be placed around the cables in front of the conduit opening.

## INSTALLATION INSTRUCTIONS FOR NOFIRNO® MULTI-CABLE TRANSIT SEALING SYSTEM

### NOFIRNO® CABLE INSERT SLEEVES

NOFIRNO® sleeve	cable diameter	sleeve length	article number	sleeve length	article number	sleeve length	article number	sleeve length	article number
12/6	5 - 7	60 <small>all dimensions in mm</small>	50.1000	80 <small>all dimensions in mm</small>	50.1240	110 <small>all dimensions in mm</small>	50.1040	130 <small>all dimensions in mm</small>	50.1200
14/8	7 - 9		50.1001		50.1241		50.1041		50.1201
16/10	9 - 11		50.1002		50.1242		50.1042		50.1202
18/12	11 - 13		50.1003		50.1243		50.1043		50.1203
20/14	13 - 15		50.1004		50.1244		50.1044		50.1204
22/16	15 - 17		50.1005		50.1245		50.1045		50.1205
26/18	17 - 19		50.1006		50.1246		50.1046		50.1206
28/20	19 - 21		50.1007		50.1247		50.1047		50.1207
30/22	21 - 23		50.1008		50.1248		50.1048		50.1208
32/24	23 - 25		50.1009		50.1249		50.1049		50.1209
34/26	25 - 27		50.1010		50.1250		50.1050		50.1210
36/28	27 - 29		50.1011		50.1251		50.1051		50.1211
38/30	29 - 32		50.1012		50.1252		50.1052		50.1212
42/33	32 - 35		50.1013		50.1253		50.1053		50.1213
46/36	35 - 38		50.1014		50.1254		50.1054		50.1214
49/39	38 - 41		50.1015		50.1255		50.1055		50.1215
52/42	41 - 44		50.1016		50.1256		50.1056		50.1216
55/45	44 - 47		50.1017		50.1257		50.1057		50.1217
58/48	47 - 51		50.1018		50.1258		50.1058		50.1218
62/52	51 - 55		50.1019		50.1259		50.1059		50.1219
66/56	55 - 59		50.1020		50.1260		50.1060		50.1220
70/60	59 - 63		50.1021		50.1261		50.1061		50.1221
74/64	63 - 67		50.1022		50.1262		50.1062		50.1222
78/68	67 - 71		50.1023		50.1263		50.1063		50.1223
82/72	71 - 75		50.1024		50.1264		50.1064		50.1224
86/76	75 - 79		50.1025		50.1265		50.1065		50.1225
95/80	79 - 84		50.1026		50.1266		50.1066		50.1226
100/85	84 - 89		50.1027		50.1267		50.1067		50.1227
110/90	89 - 94		50.1028		50.1268		50.1068		50.1228
115/95	94 - 99		50.1029		50.1269		50.1069		50.1229
120/100	99 - 104	50.1030	50.1270	50.1070	50.1230				

NOFIRNO® sleeve	cable diameter	sleeve length	article number	sleeve length	article number	sleeve length	article number	sleeve length	article number
12/6	5 - 7	140 <small>all dimensions in mm</small>	50.1080	160 <small>all dimensions in mm</small>	50.1120	210 <small>all dimensions in mm</small>	50.1160		
14/8	7 - 9		50.1081		50.1121		50.1161		
16/10	9 - 11		50.1082		50.1122		50.1162		
18/12	11 - 13		50.1083		50.1123		50.1163		
20/14	13 - 15		50.1084		50.1124		50.1164		
22/16	15 - 17		50.1085		50.1125		50.1165		
26/18	17 - 19		50.1086		50.1126		50.1166		
28/20	19 - 21		50.1087		50.1127		50.1167		
30/22	21 - 23		50.1088		50.1128		50.1168		
32/24	23 - 25		50.1089		50.1129		50.1169		
34/26	25 - 27		50.1090		50.1130		50.1170		
36/28	27 - 29		50.1091		50.1131		50.1171		
38/30	29 - 32		50.1092		50.1132		50.1172		
42/33	32 - 35		50.1093		50.1133		50.1173		
46/36	35 - 38		50.1094		50.1134		50.1174		
49/39	38 - 41		50.1095		50.1135		50.1175		
52/42	41 - 44		50.1096		50.1136		50.1176		
55/45	44 - 47		50.1097		50.1137		50.1177		
58/48	47 - 51		50.1098		50.1138		50.1178		
62/52	51 - 55		50.1099		50.1139		50.1179		
66/56	55 - 59		50.1100		50.1140		50.1180		
70/60	59 - 63		50.1101		50.1141		50.1181		
74/64	63 - 67		50.1102		50.1142		50.1182		
78/68	67 - 71		50.1103		50.1143		50.1183		
82/72	71 - 75		50.1104		50.1144		50.1184		
86/76	75 - 79		50.1105		50.1145		50.1185		
95/80	79 - 84		50.1106		50.1146		50.1186		
100/85	84 - 89		50.1107		50.1147		50.1187		
110/90	89 - 94		50.1108		50.1148		50.1188		
115/95	94 - 99		50.1109		50.1149		50.1189		
120/100	99 - 104	50.1110	50.1150	50.1190					

## INSTALLATION INSTRUCTIONS FOR NOFIRNO® MULTI-CABLE TRANSIT SEALING SYSTEM

### NOFIRNO® MULTI-FILLER SLEEVES



Filler sleeves are not split lengthwise

Operating temperatures:  
-50 °C up to +180 °C

NOFIRNO® filler sleeves are supplied in multi-sets of 6, 8 and 10 sleeves, depending on the outer dimensions of the sleeves. Single sleeves or smaller sets of sleeves can be torn off easily. To tear off sleeves from the multi-set, the procedure is to do this backwards/forwards and not sideways. This is because of the strength of the intermediate rubber parts.

## INSTALLATION INSTRUCTIONS FOR NOFIRNO® MULTI-CABLE TRANSIT SEALING SYSTEM

### NOFIRNO® MULTI-FILLER SLEEVES

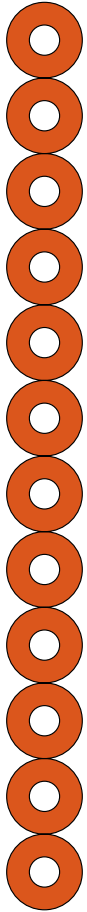

**NOFIRNO® Filler sleeve 10/4 multi 12**

- art. no. 50.0301 for 60 mm length
- art. no. 50.0361 for 80 mm length
- art. no. 50.0311 for 110 mm length
- art. no. 50.0351 for 130 mm length
- art. no. 50.0321 for 140 mm length
- art. no. 50.0331 for 160 mm length
- art. no. 50.0341 for 210 mm length

to be used for smaller conduit openings

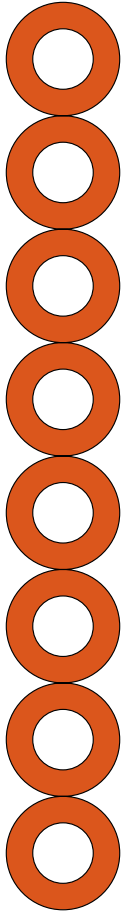

**NOFIRNO® Filler sleeve 15/8 multi 8**

- art. no. 50.0302 for 60 mm length
- art. no. 50.0362 for 80 mm length
- art. no. 50.0312 for 110 mm length
- art. no. 50.0352 for 130 mm length
- art. no. 50.0322 for 140 mm length
- art. no. 50.0332 for 160 mm length
- art. no. 50.0342 for 210 mm length

**NOFIRNO® Filler sleeve 20/12 multi 6**

- art. no. 50.0303 for 60 mm length
- art. no. 50.0363 for 80 mm length
- art. no. 50.0313 for 110 mm length
- art. no. 50.0353 for 130 mm length
- art. no. 50.0323 for 140 mm length
- art. no. 50.0333 for 160 mm length
- art. no. 50.0343 for 210 mm length

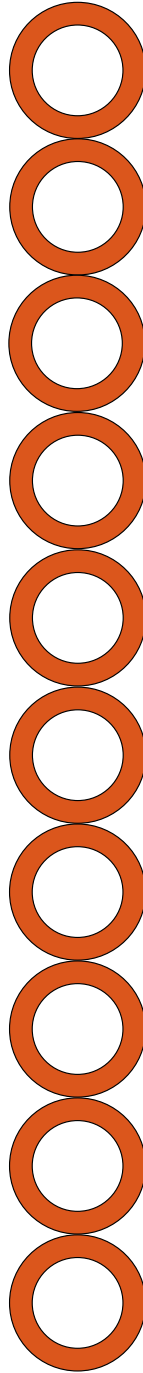

**NOFIRNO® Filler sleeve 18/12 multi 10**

- art. no. 80.5050 for 60 mm length
- art. no. 80.5056 for 80 mm length
- art. no. 80.5051 for 110 mm length
- art. no. 80.5055 for 130 mm length
- art. no. 80.5052 for 140 mm length
- art. no. 80.5053 for 160 mm length
- art. no. 80.5054 for 210 mm length

to be used for larger conduit openings

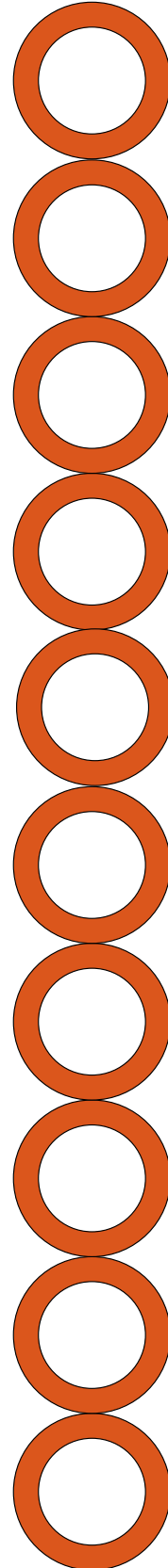

**NOFIRNO® Filler sleeve 22/15 multi 10**

- art. no. 80.5070 for 60 mm length
- art. no. 80.5076 for 80 mm length
- art. no. 80.5071 for 110 mm length
- art. no. 80.5075 for 130 mm length
- art. no. 80.5072 for 140 mm length
- art. no. 80.5073 for 160 mm length
- art. no. 80.5074 for 210 mm length

to be used for larger conduit openings

Filler sleeves are supplied non-split

Operating temperatures:  
-50 °C up to +180 °C

## INSTALLATION INSTRUCTIONS FOR NOFIRNO® MULTI-CABLE TRANSIT SEALING SYSTEM



The tools needed for the installation are an air blower (or a brush), a tie-wrap cutter, a cutter for the nozzles of the sealant cartridges, flat nose pliers to adjust the set of fillers, a filler set adjuster, a tool for pressing the sealant layer in between the cables, cloths for cleaning and compression of the sealant layer, a cable cleaner, a bucket with water and a professional sealant dispenser.

## INSTALLATION INSTRUCTIONS FOR NOFIRNO® MULTI-CABLE TRANSIT SEALING SYSTEM

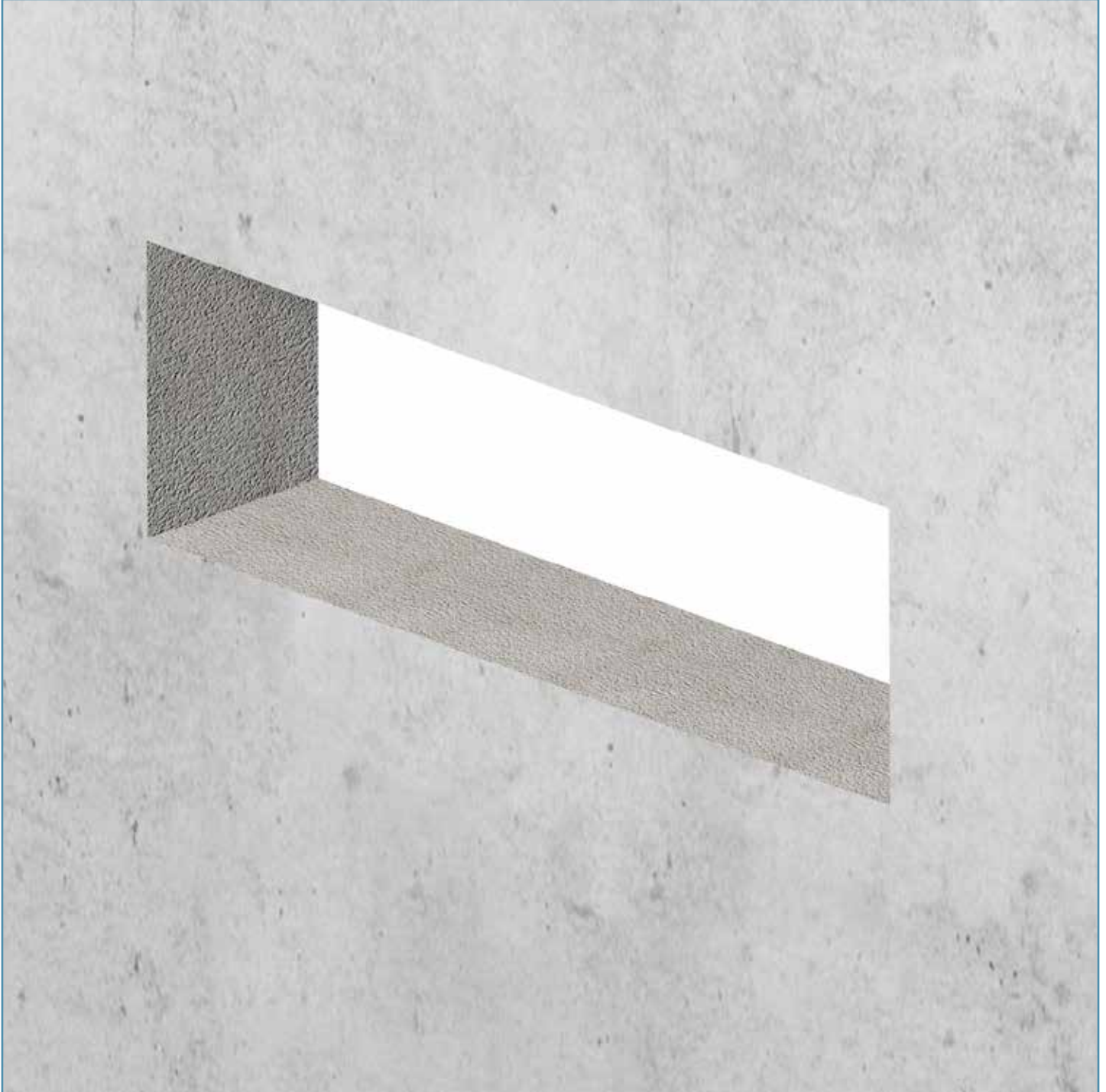

The conduit opening can be maximum size 600x600 mm or an equivalent of 3600 cm<sup>2</sup>. Wall thickness minimum 100 mm. No metal transit frames are required. Cable trays should not be passed through the conduit opening, in order to ensure maximum fire and tightness ratings.

## INSTALLATION INSTRUCTIONS FOR NO FIRNO® MULTI-CABLE TRANSIT SEALING SYSTEM

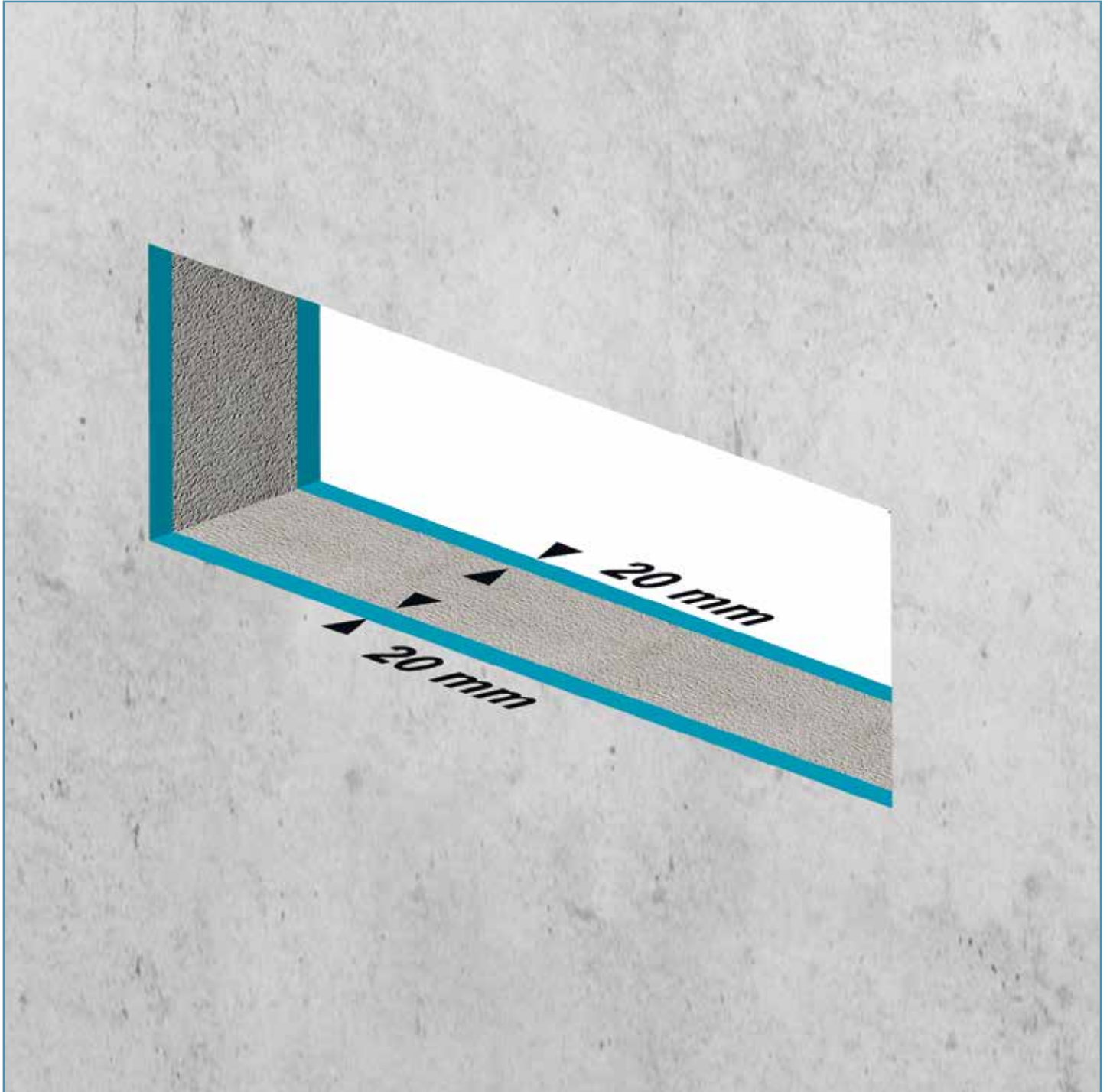

The NO FIRNO® sealing system is composed of cable and filler sleeves, and layers of sealant. The sleeves are the backing on which the sealant is going to be applied. A 20 mm thick layer of sealant is applied at both sides of the penetration. The NO FIRNO® cable and filler sleeves are 40 mm shorter in length than the depth of the conduit opening.

Note: for high rated watertight penetrations, the conduit opening should be either of a limited size or partitions should be placed inside the larger openings to divide the conduit into smaller sections.

## INSTALLATION INSTRUCTIONS FOR NOFIRNO® MULTI-CABLE TRANSIT SEALING SYSTEM

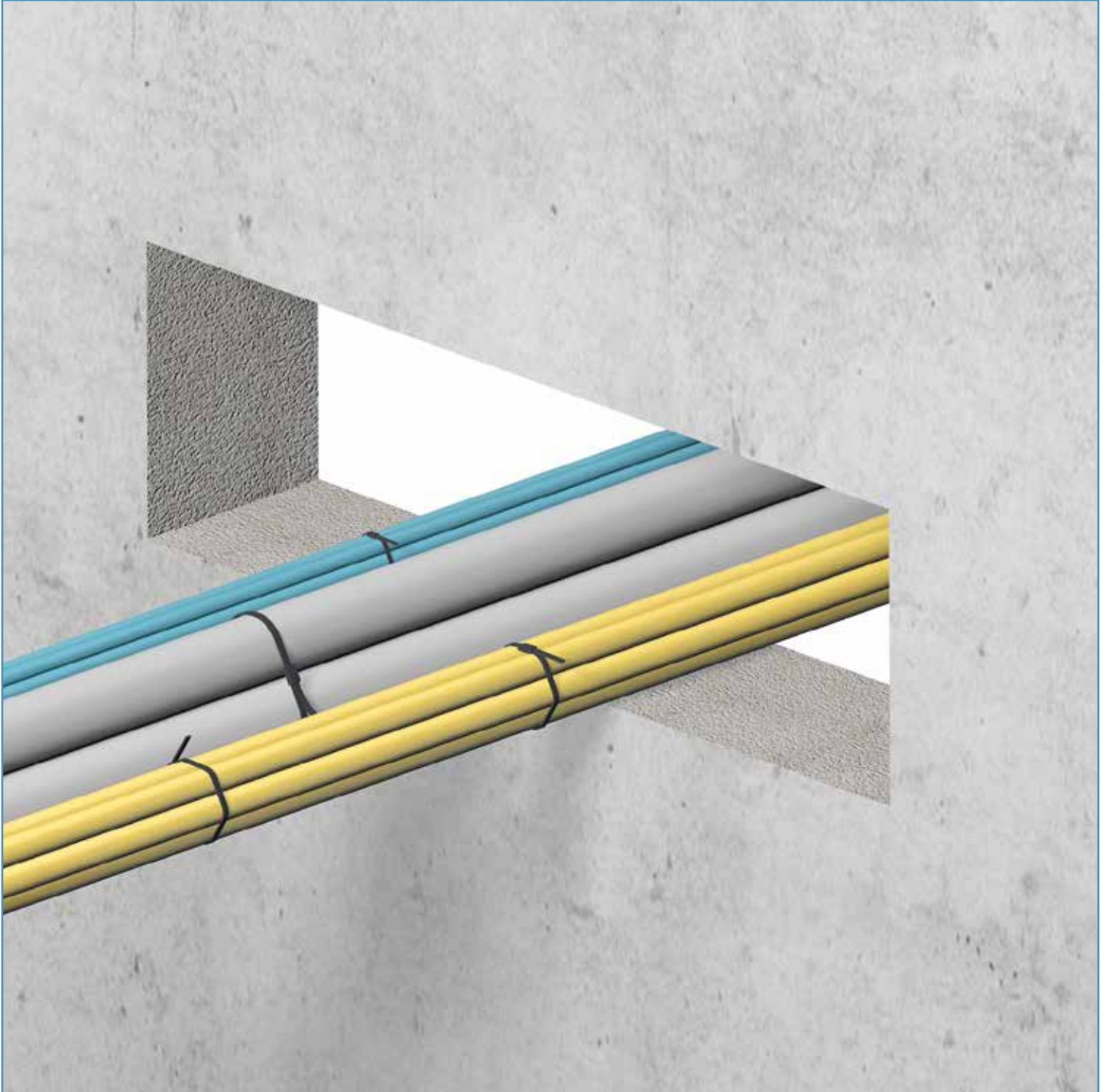

The cables can be ducted through the conduit opening in random order. It is most important that they are not pulled too tight so as not to hamper their separation when NOFIRNO® cable insert sleeves are inserted. Open conduits at site allow for pulling more cables through than planned. Sealing the multi-cable penetration will then be difficult or not possible at all. Tangled cable sets can make the installation of the sealing system extremely difficult. Ease of installation starts with organized pulling of the cables through the conduit openings.

## INSTALLATION INSTRUCTIONS FOR NOFIRNO® MULTI-CABLE TRANSIT SEALING SYSTEM

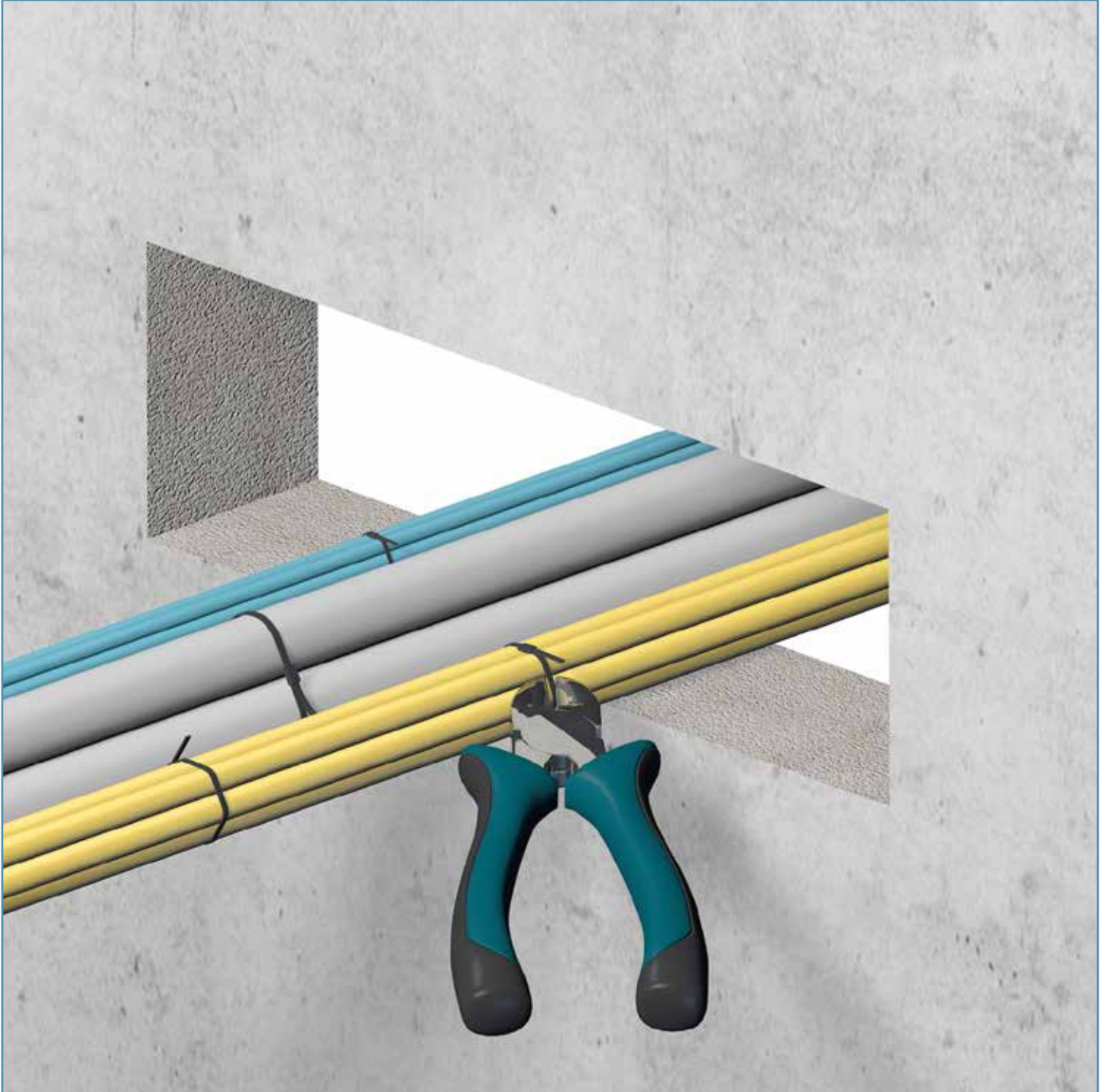

The cable tie-wraps have to be removed to create enough play in between the cables to enable cleaning of the cables and to allow insertion of the NOFIRNO® cable insert sleeves in a later stage.

## INSTALLATION INSTRUCTIONS FOR NOFIRNO® MULTI-CABLE TRANSIT SEALING SYSTEM

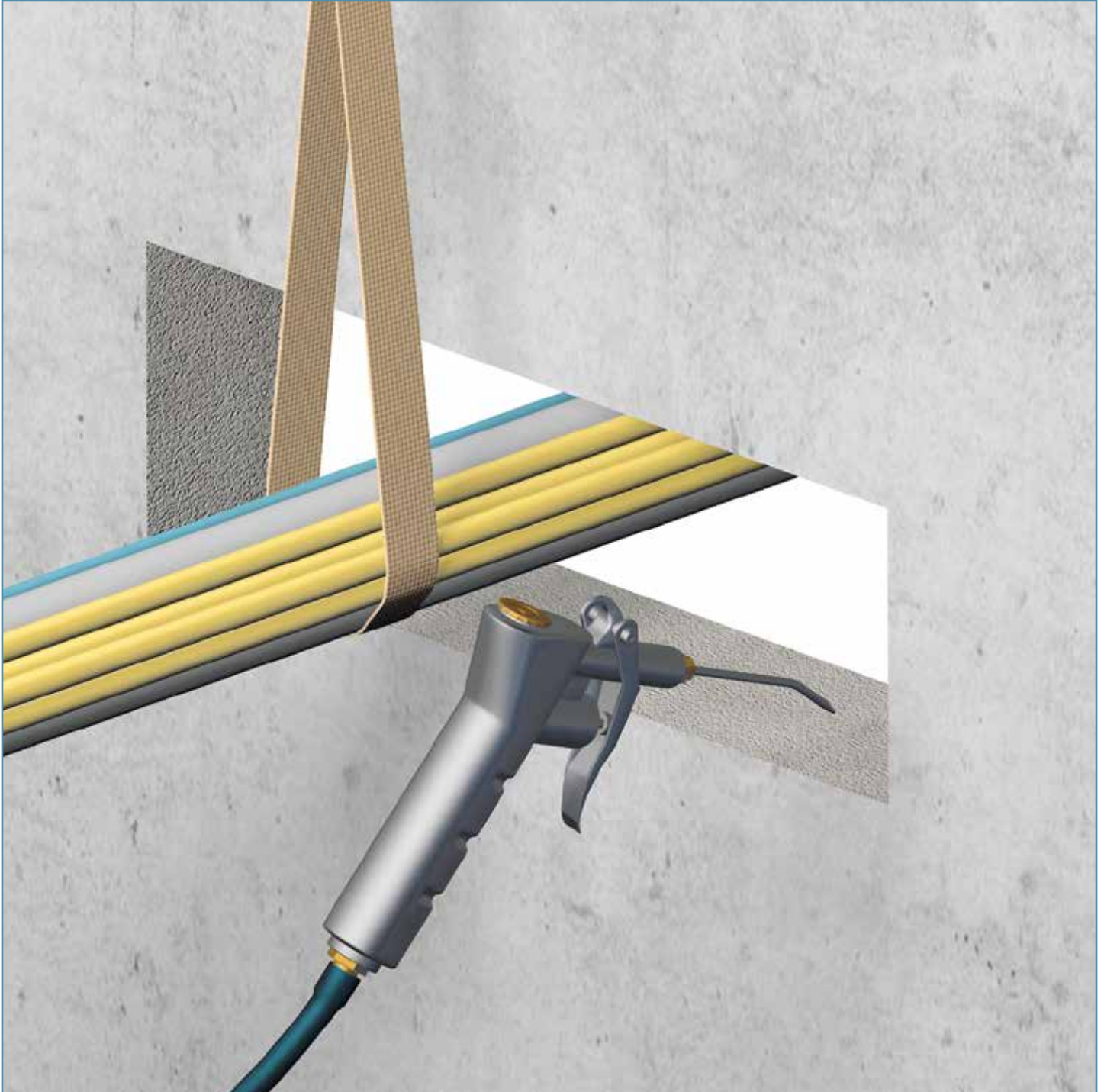

For adequate cleaning purposes (which is an important step), the cables could be lifted with a band to create sufficient access to the inner wall of the conduit opening. Before starting with the installation of the sealing system, remove any dust and other residues with a brush or by air blowing.

## INSTALLATION INSTRUCTIONS FOR NOFIRNO® MULTI-CABLE TRANSIT SEALING SYSTEM



Clean and dry the ducted cables thoroughly. Any moisture, dirt or oil residues will have a negative impact on the adhesive properties of the NOFIRNO® sealant to be applied after filling the conduit opening.

## INSTALLATION INSTRUCTIONS FOR NOFIRNO® MULTI-CABLE TRANSIT SEALING SYSTEM

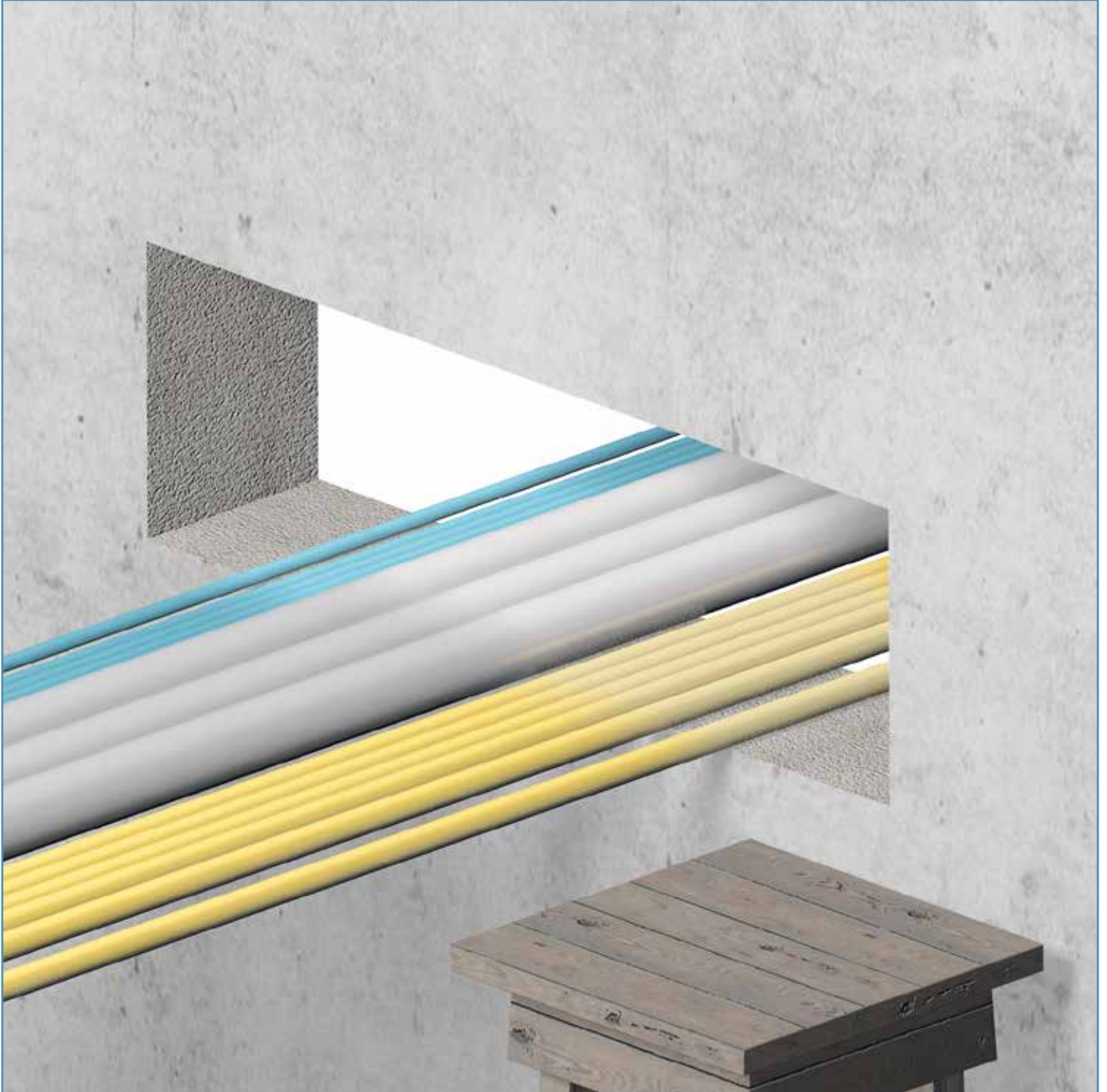

The cables have to be cleaned at the spot where the sealant is to be applied in a later stage. This means 20 mm at both sides of the transit. If feasible, it is of course easier to clean the cables over their full length inside the conduit opening.

## INSTALLATION INSTRUCTIONS FOR NOFIRNO® MULTI-CABLE TRANSIT SEALING SYSTEM

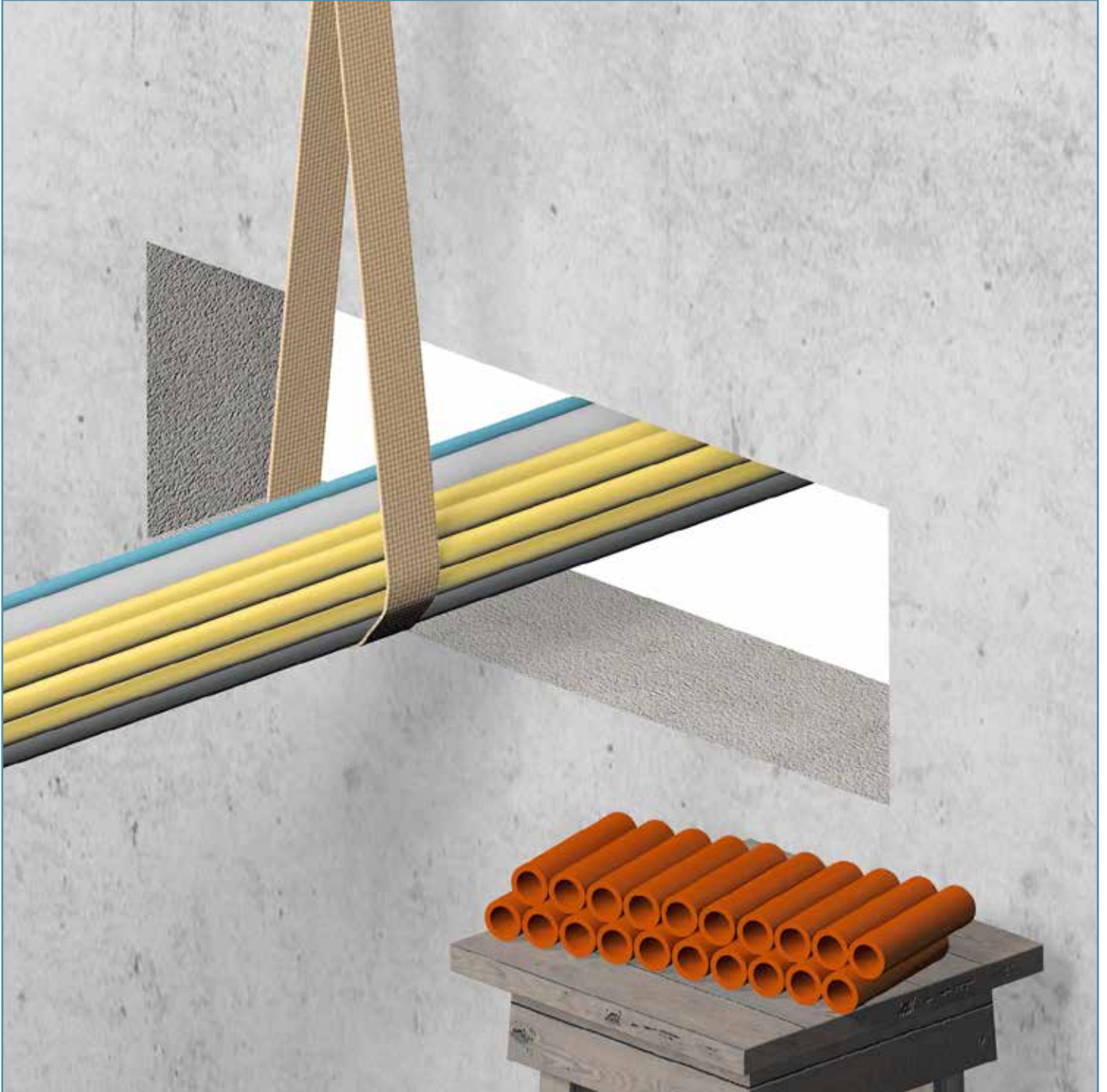

Although the system is tested with the cables separated from the wall of the conduit opening by the thickness of the NOFIRNO® cable insert sleeves, it is advisable to have a layer of NOFIRNO® multi-sleeves at the bottom of the conduit opening prior to spreading out the cables.

## INSTALLATION INSTRUCTIONS FOR NOFIRNO® MULTI-CABLE TRANSIT SEALING SYSTEM

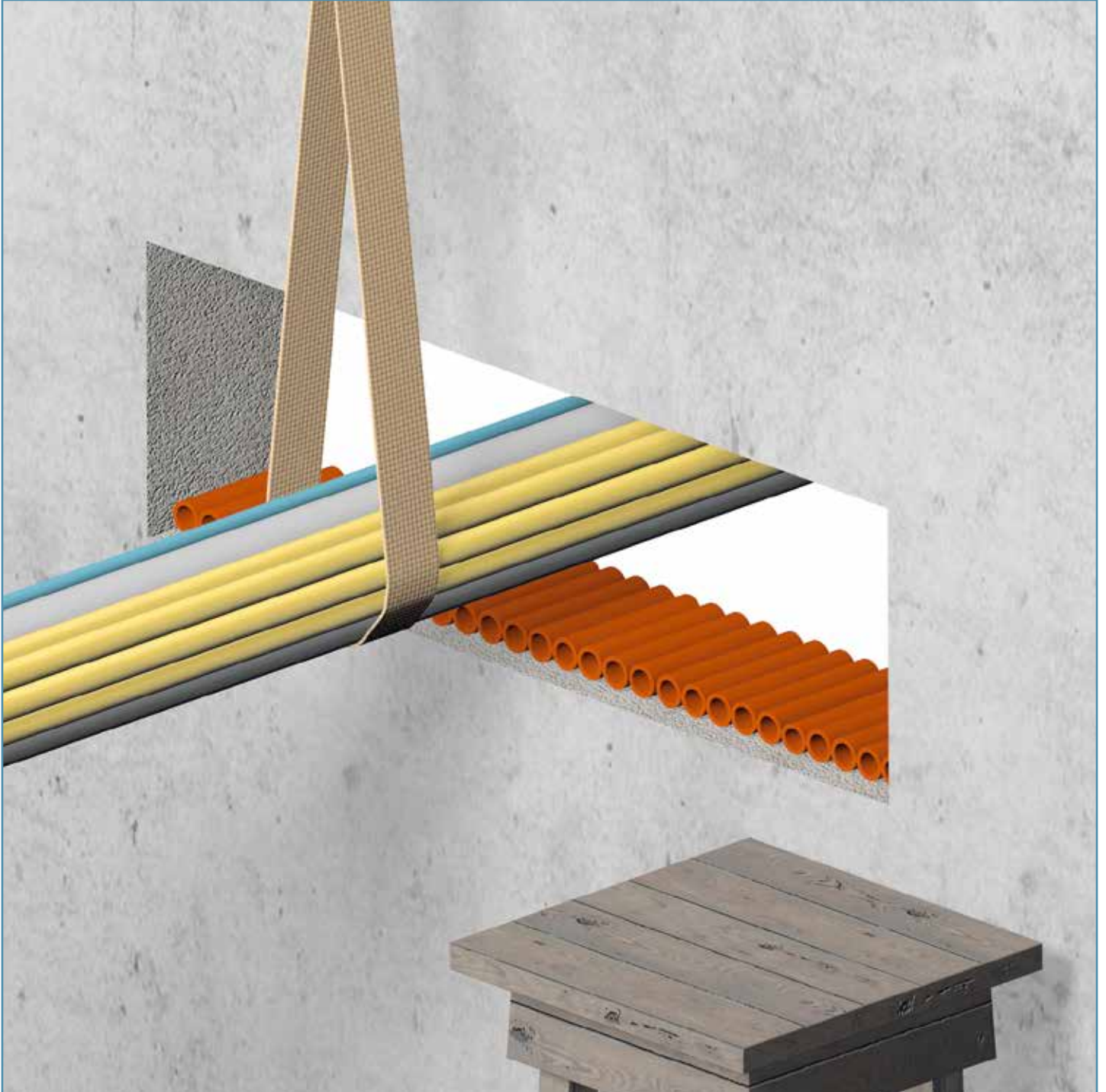

By lifting the cables, the set(s) of NOFIRNO® multi-filler sleeves can be easily placed inside the conduit opening.

## INSTALLATION INSTRUCTIONS FOR NOFIRNO® MULTI-CABLE TRANSIT SEALING SYSTEM

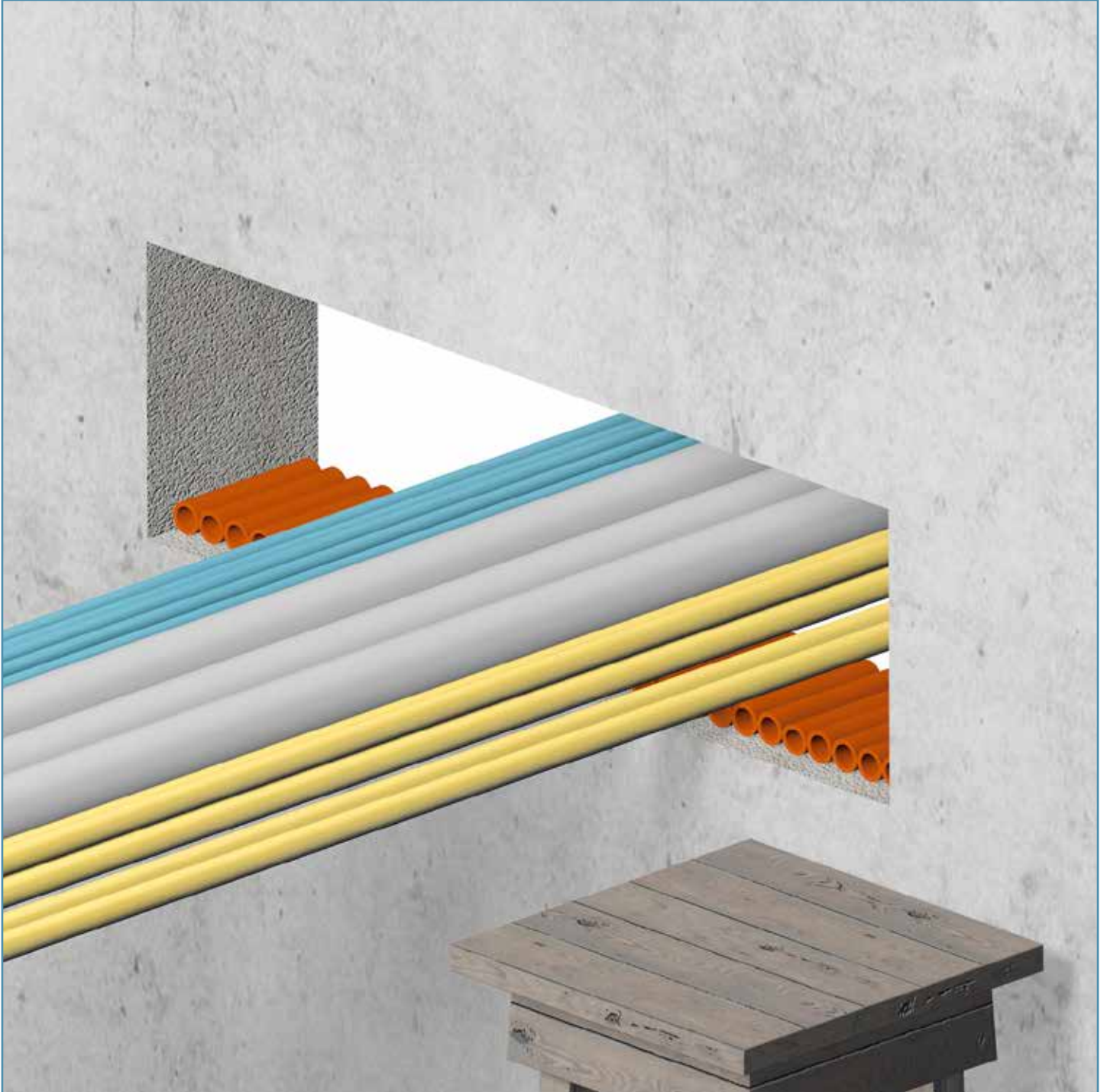

The cables are then separated as far as possible on top of the NOFIRNO® multi-filler sleeves. The application of the NOFIRNO® multi-filler sleeves underneath the cables makes the application of the sealant for final finishing at the bottom of the conduit opening not only easier but also more effective. NOFIRNO® multi-filler sleeves also prevent the cables from touching the concrete or brick wall, which can lead to shaving and damaging of the cables.

## INSTALLATION INSTRUCTIONS FOR NOFIRNO® MULTI-CABLE TRANSIT SEALING SYSTEM

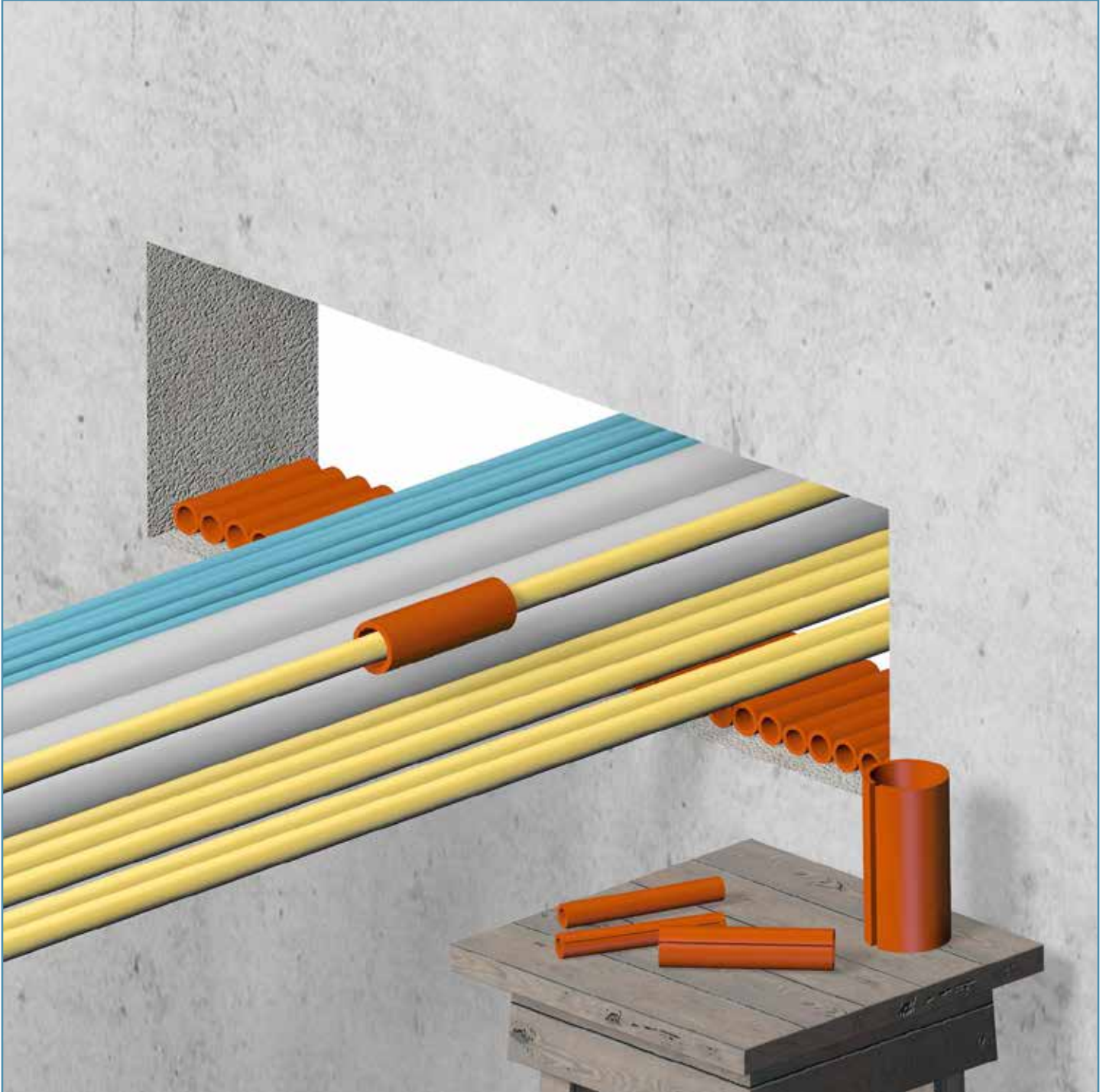

NOFIRNO® cable insert sleeves are separators and not precise filling parts. Applying oversized sleeves around the cables will reduce the filling capacity of the sealing system. Due to the fact that the NO-FIRNO® rubber is very endothermic and is fully protected by the NOFIRNO® sealant, this will not, however, have an influence on the fire rating as long the sleeves are not extremely oversized.

## INSTALLATION INSTRUCTIONS FOR NOFIRNO® MULTI-CABLE TRANSIT SEALING SYSTEM

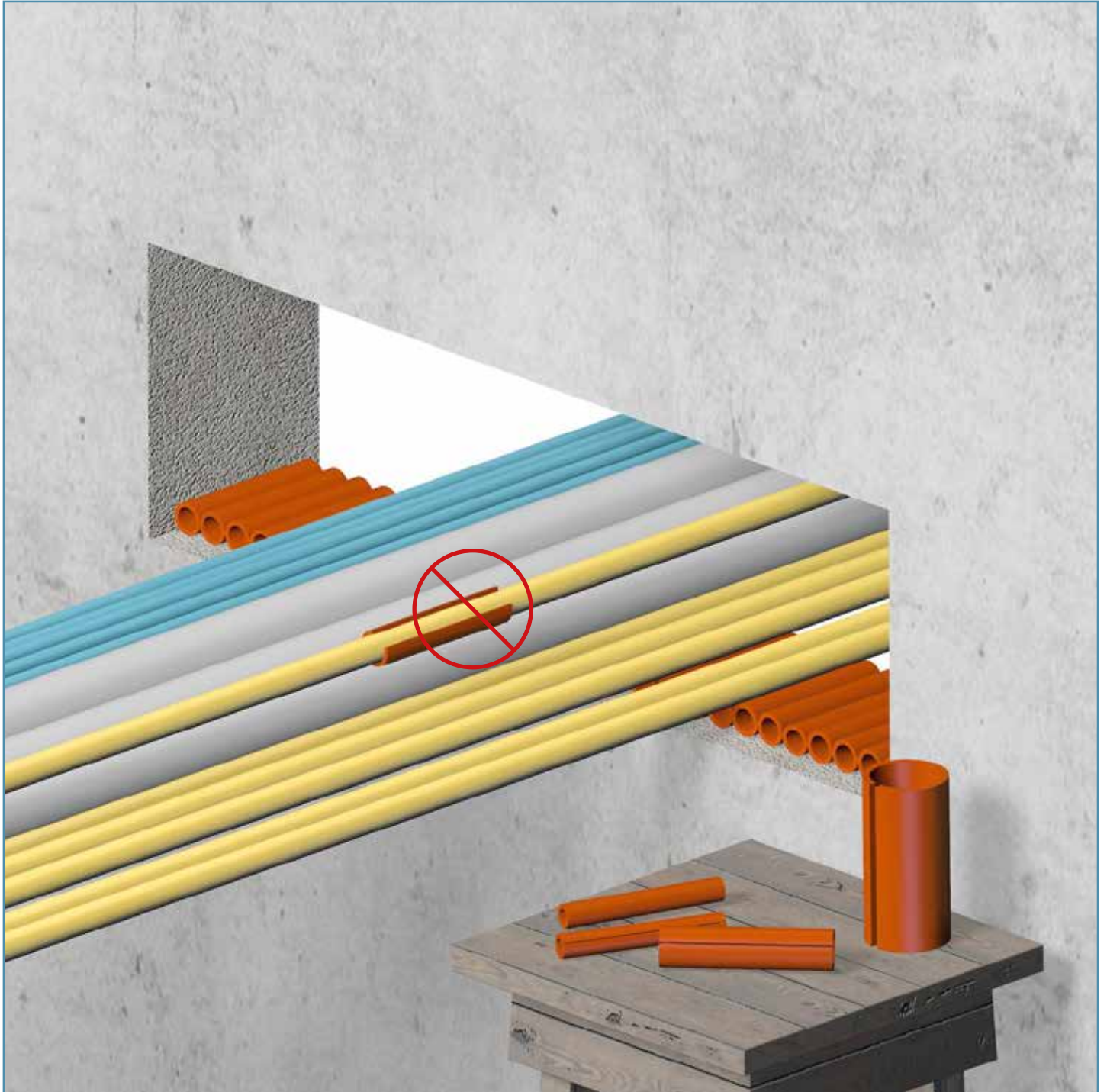

A precise fit of the NOFIRNO® cable sleeves around the cables is not required, however it is not allowed to use undersized cable sleeves leaving a larger open space around the cable. See the tables on page 4.

## INSTALLATION INSTRUCTIONS FOR NOFIRNO® MULTI-CABLE TRANSIT SEALING SYSTEM

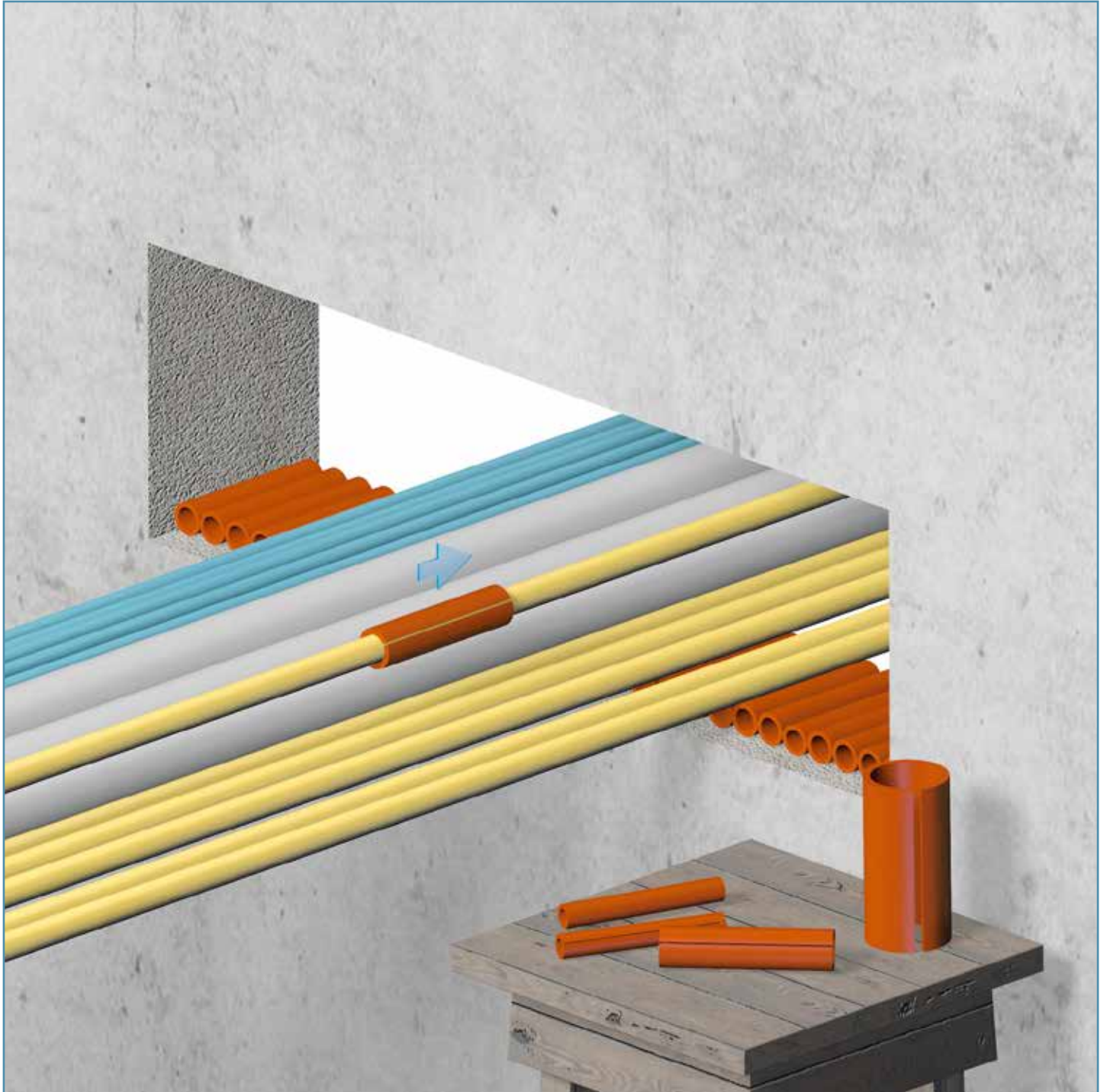

NOFIRNO® cable insert sleeves are applied around each cable. The cable insert sleeves are split lengthwise and can therefore be placed around the cables in front of the conduit opening.

## INSTALLATION INSTRUCTIONS FOR NOFIRNO® MULTI-CABLE TRANSIT SEALING SYSTEM

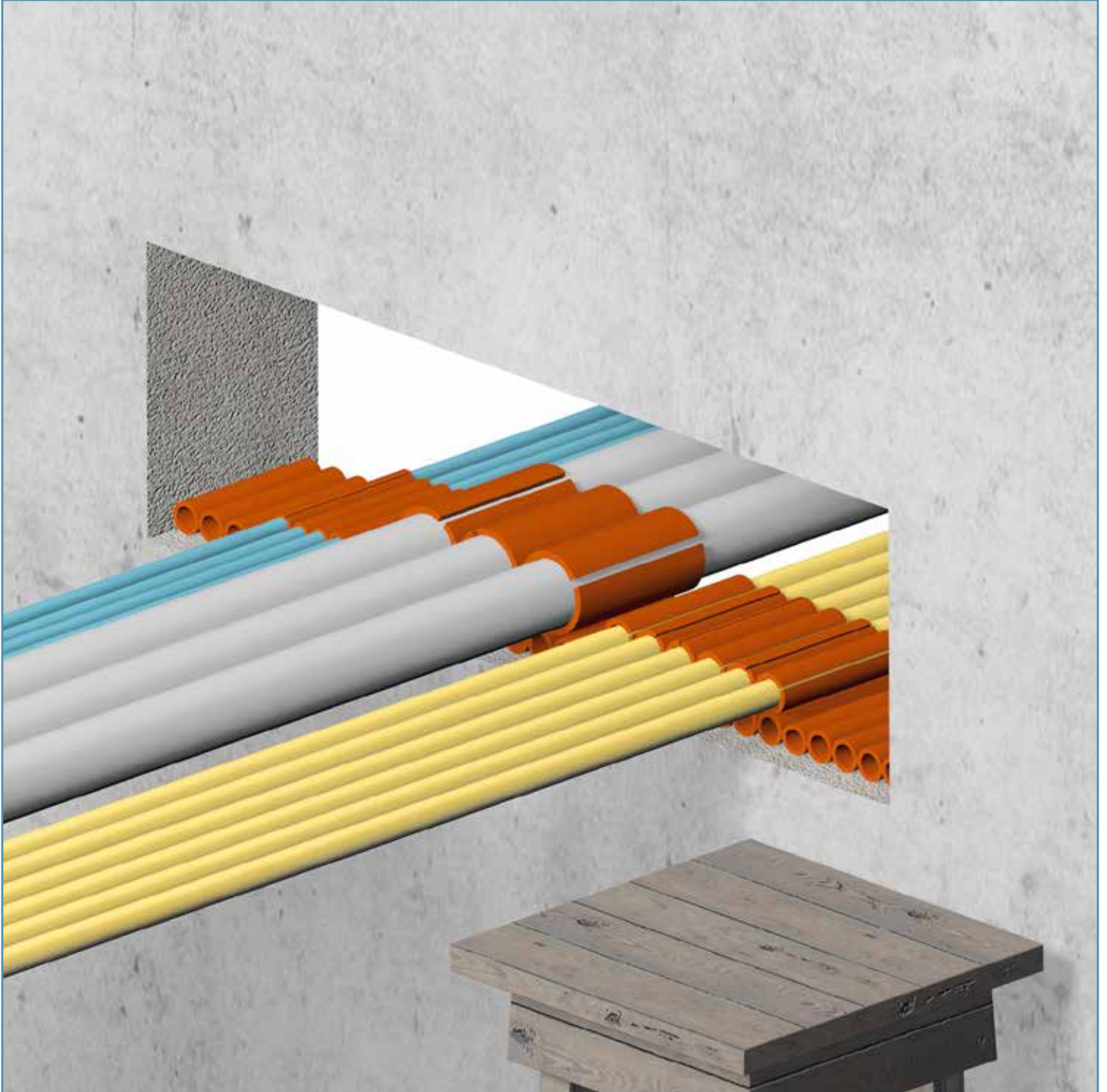

Push the cable insert sleeves into the conduit opening in such a way as to leave about 20 mm free space at the front and the back. At this stage, and certainly with a low filling rate of cables, the insertion does not have to be precise in this regard. Adjustment of the set of sleeves to the 20 mm recess can be carried out just before applying the sealant. However, with higher filling rates, it might be difficult to correct afterwards.

## INSTALLATION INSTRUCTIONS FOR NOFIRNO® MULTI-CABLE TRANSIT SEALING SYSTEM

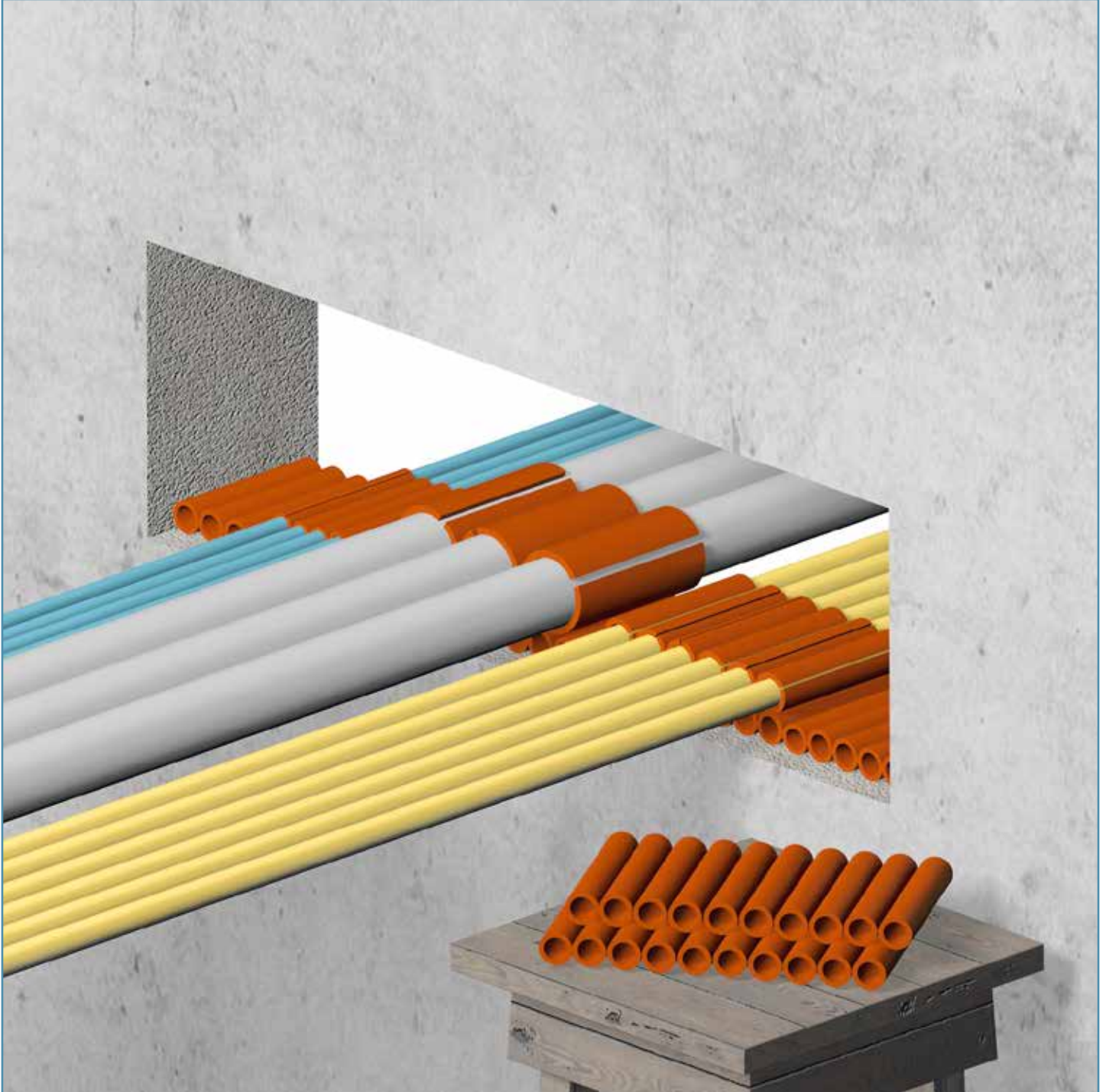

The remaining free space in the conduit opening is filled with NOFIRNO® filler sleeves type 18/12, 20/12 or 22/15 or a combination of these types. The smaller sleeves sizes 10/4 and 15/8 are used to fill smaller open spaces present in the complete set of filler sleeves. For ease of filling, the NOFIRNO® filler sleeves are supplied non-split. They are delivered also as multi-filler sleeves (multi-sets of 6, 8 and 10 sleeves) which is extremely helpful for filling larger empty spaces.

## INSTALLATION INSTRUCTIONS FOR NOFIRNO® MULTI-CABLE TRANSIT SEALING SYSTEM

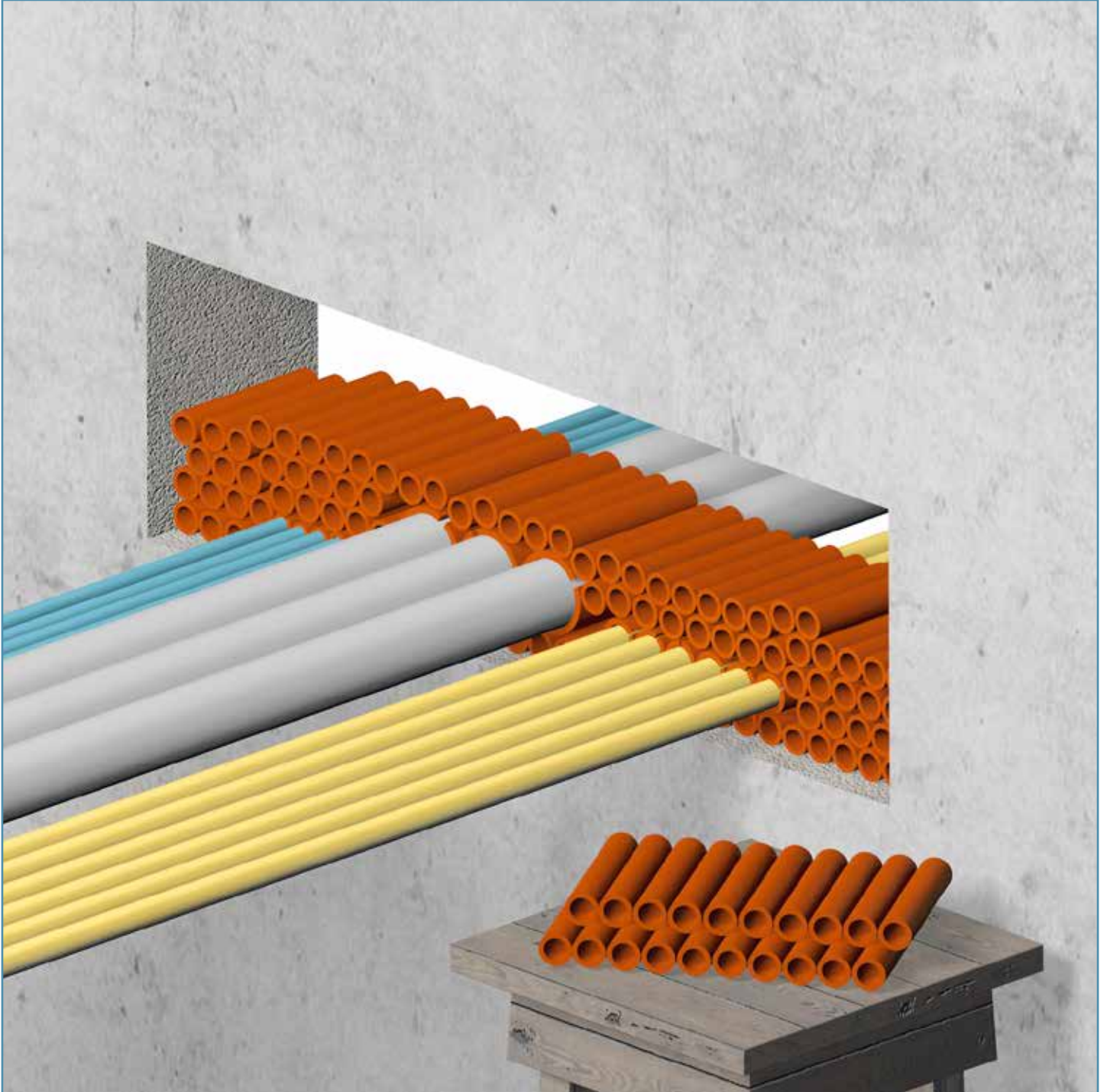

For later extensions, it is advisable to use NOFIRNO® single filler sleeves, since they are easier to remove when a new cable has to be ducted.

## INSTALLATION INSTRUCTIONS FOR NOFIRNO® MULTI-CABLE TRANSIT SEALING SYSTEM

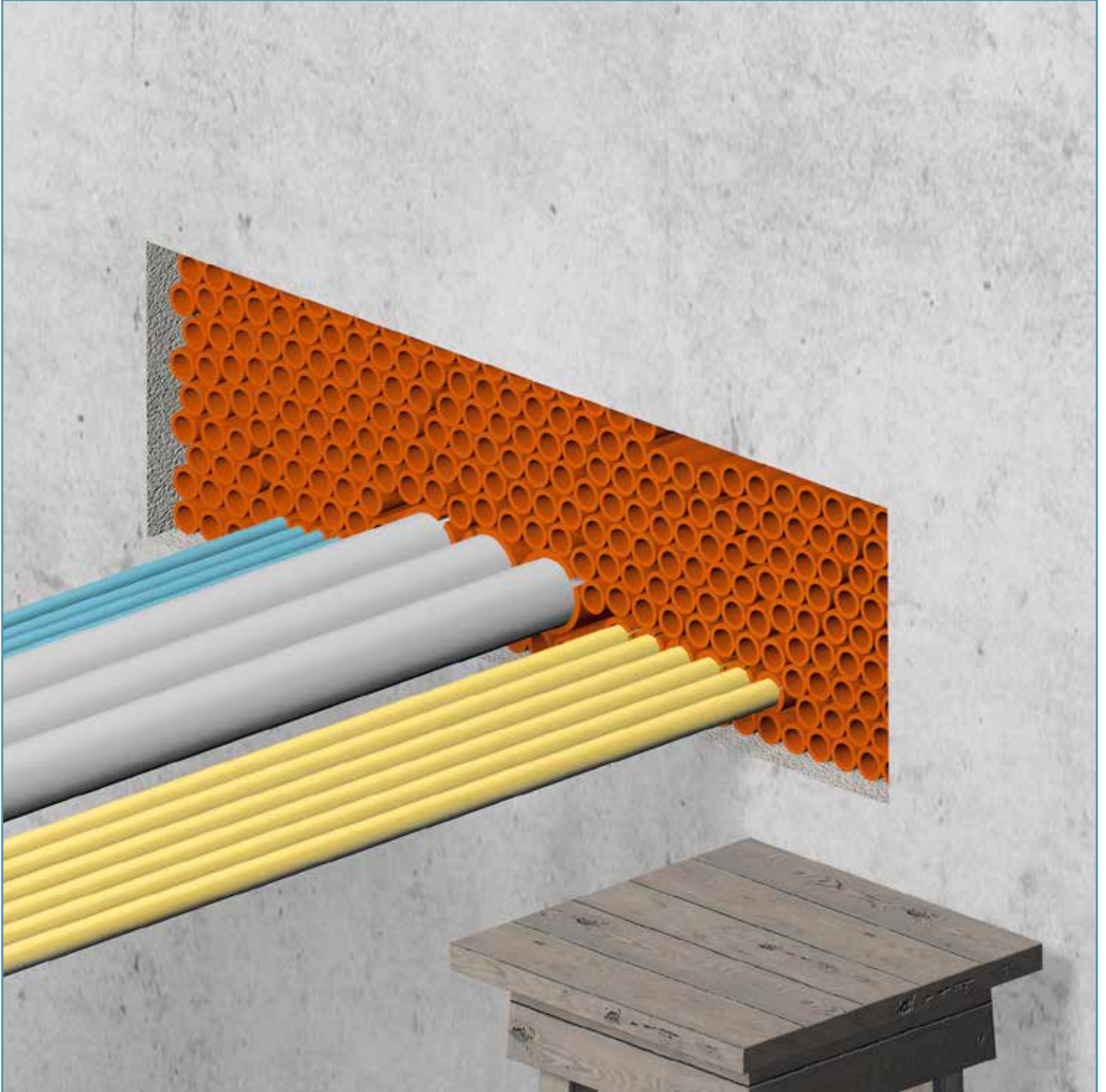

It is allowed to use one type of NOFIRNO® filler sleeves only or a mix of all types of NOFIRNO® filler sleeves.

## INSTALLATION INSTRUCTIONS FOR NOFIRNO® MULTI-CABLE TRANSIT SEALING SYSTEM

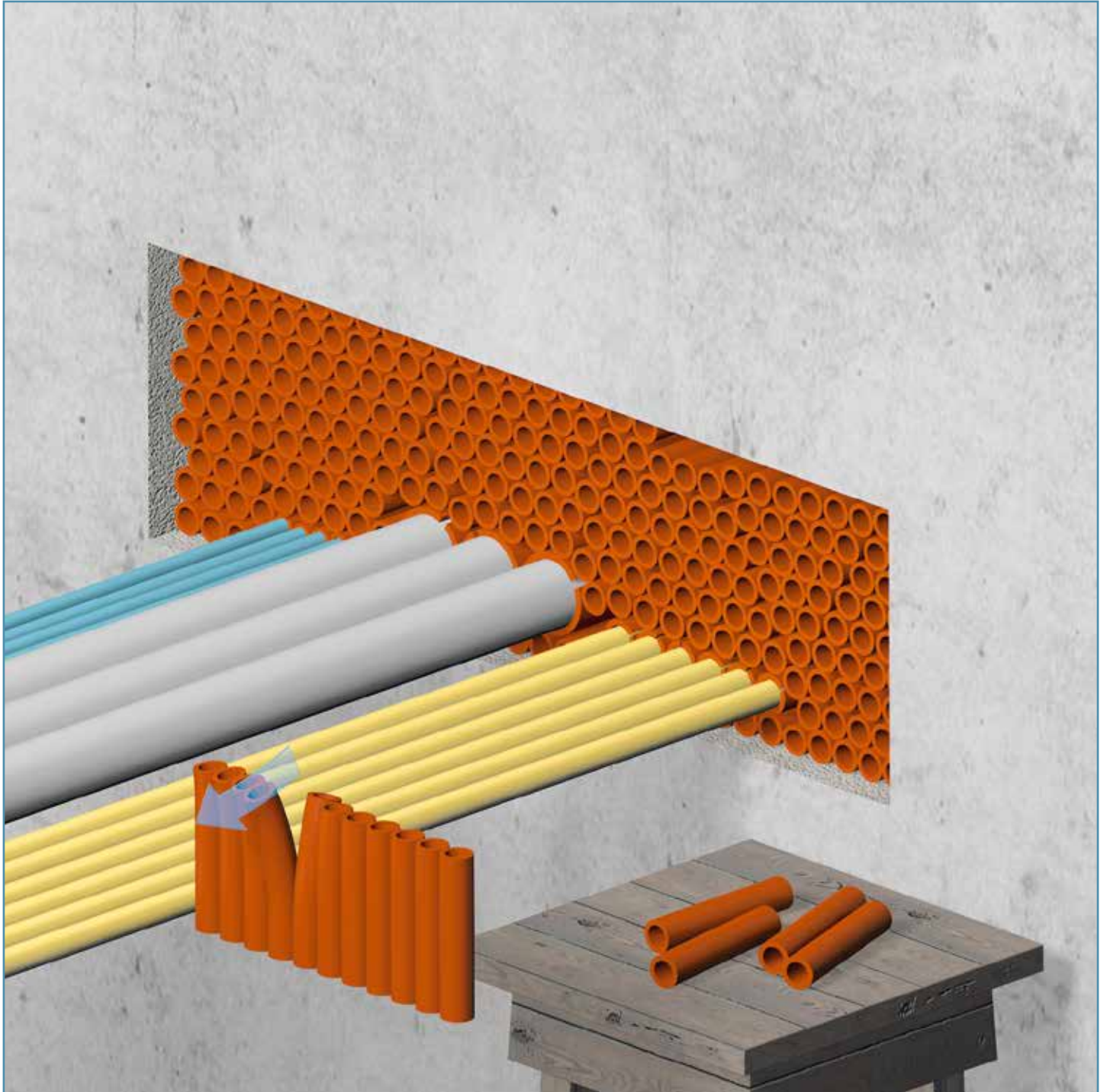

The smaller openings are now filled with parts of the sets of multi-filler sleeves. To tear off sleeves from the multi-set, the procedure is to do this backwards/forwards and not sideways. This is because of the strength of the intermediate rubber parts.

## INSTALLATION INSTRUCTIONS FOR NOFIRNO® MULTI-CABLE TRANSIT SEALING SYSTEM



With a flat nose pliers, NOFIRNO® single filler sleeves are inserted in the remaining smaller open spaces in the set of fillers. A very tight fit of the filling is vital to the performance of the sealing system.

## INSTALLATION INSTRUCTIONS FOR NOFIRNO® MULTI-CABLE TRANSIT SEALING SYSTEM

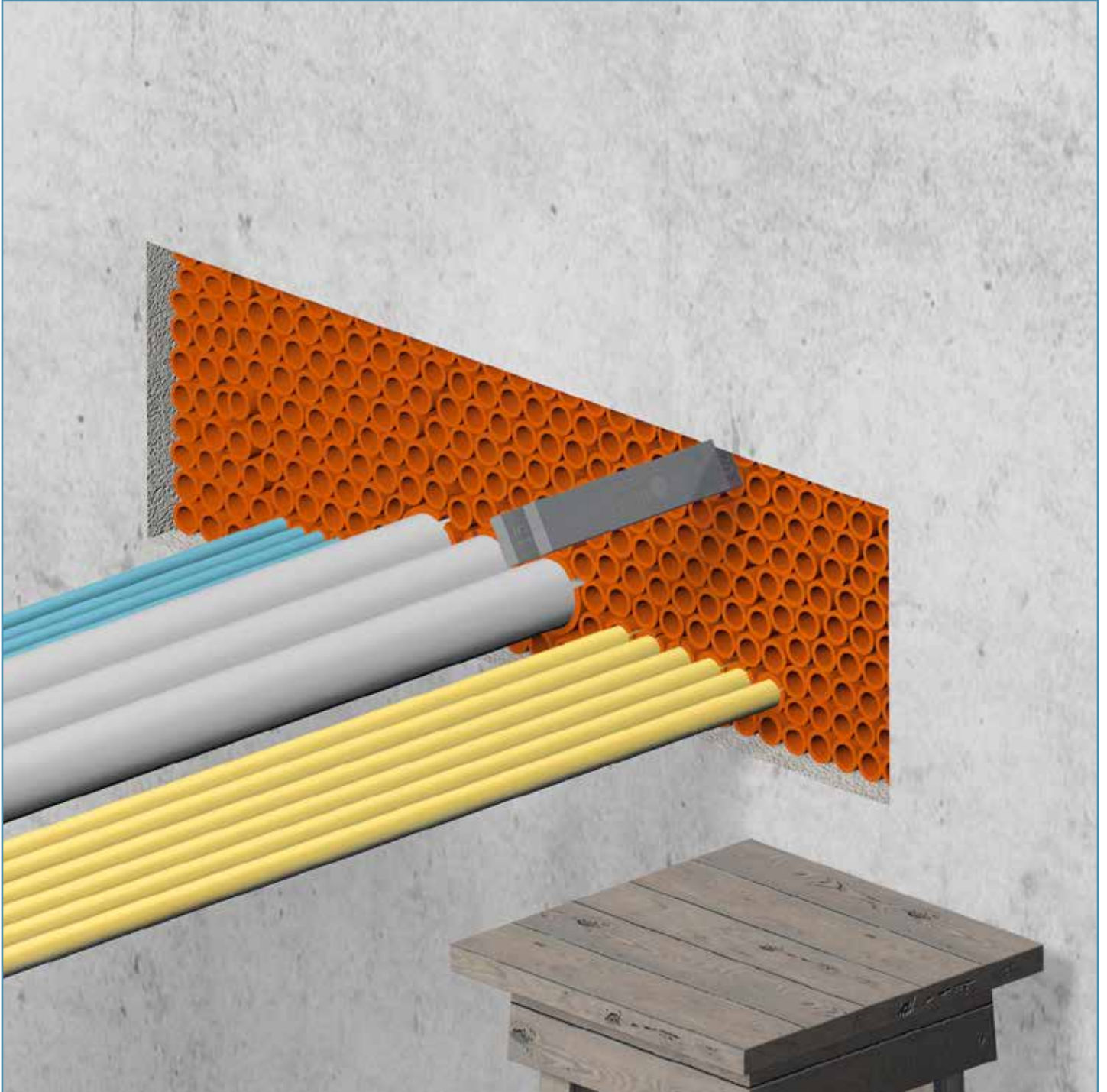

With the BEELE Engineering developed aluminum adjuster, the set of fillers can be adjusted to the required 20 mm recess inside the conduit opening. Use a plastic hammer to adjust the set of filler sleeves with the NOFIRNO® adjuster. A piece of wood can of course be used for this purpose as well.

## INSTALLATION INSTRUCTIONS FOR NOFIRNO® MULTI-CABLE TRANSIT SEALING SYSTEM



The filler set can be further adjusted with the aid of a flat nose pliers. Single filler sleeves sometimes might be inserted too deep and have to be pulled back.

A ca. 20 mm free space at the front and back of the sealing system (+/- 2 mm tolerance is acceptable) is a must to obtain optimum sealing capacity of the sealing system.

## INSTALLATION INSTRUCTIONS FOR NOFIRNO® MULTI-CABLE TRANSIT SEALING SYSTEM

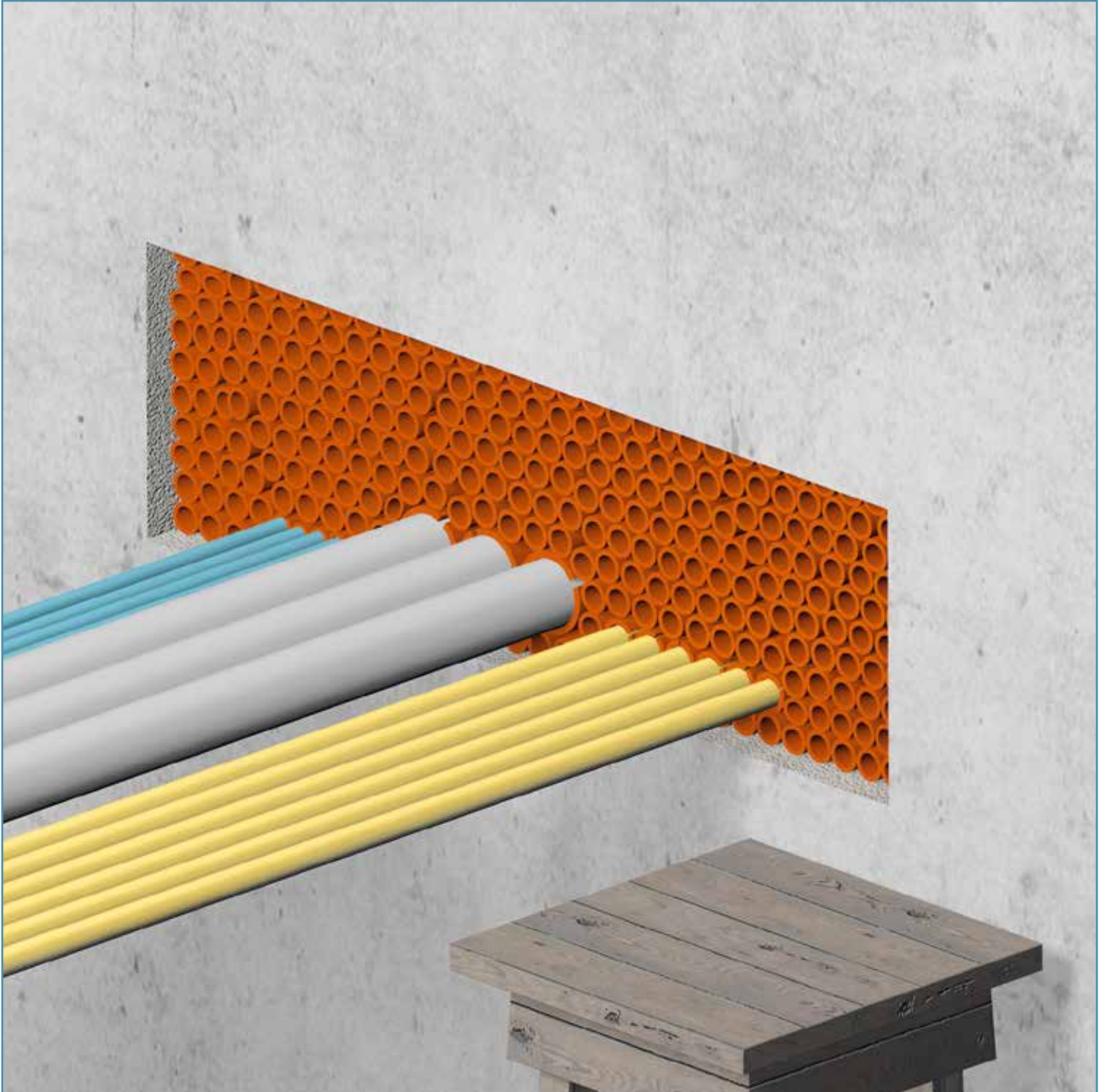

Before applying the NOFIRNO® sealant, it is advisable to perform a final check on the packing of the cable insert and filler sleeves. A tight fit of the whole set of sleeves is not only vital for the mechanical stability of the sealing system, but also for the fire stopping properties. A final check should therefore be a part of quality control.

## INSTALLATION INSTRUCTIONS FOR NOFIRNO® MULTI-CABLE TRANSIT SEALING SYSTEM

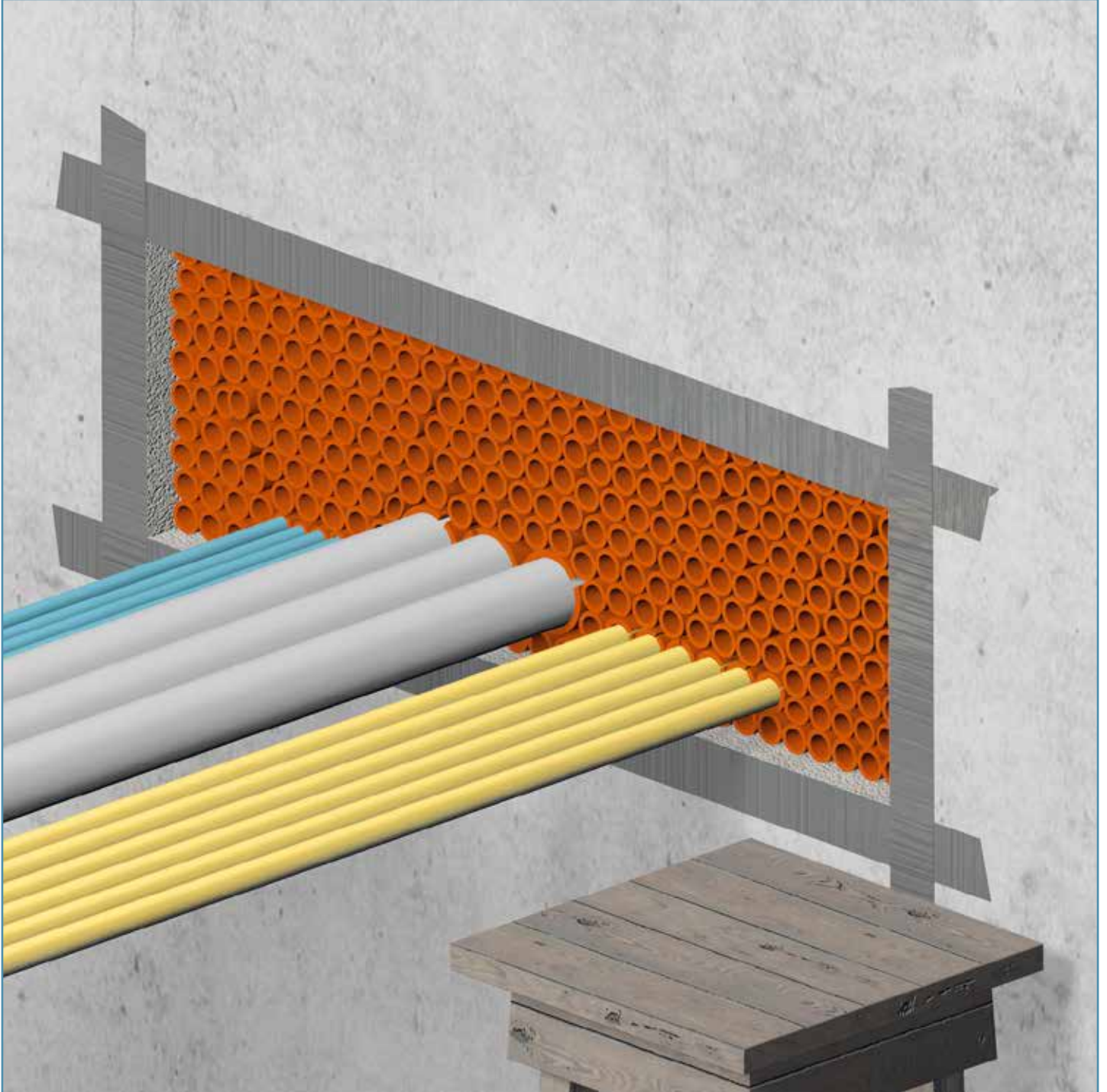

Before applying the NOFIRNO® sealant, it is advisable to tape the wall all around the conduit opening to keep the wall free from any sealant residues.

Clean and dry the inside wall of the conduit and the cables thoroughly, and remove any dirt, rust or oil residues before applying the sealant.

## INSTALLATION INSTRUCTIONS FOR NOFIRNO® MULTI-CABLE TRANSIT SEALING SYSTEM

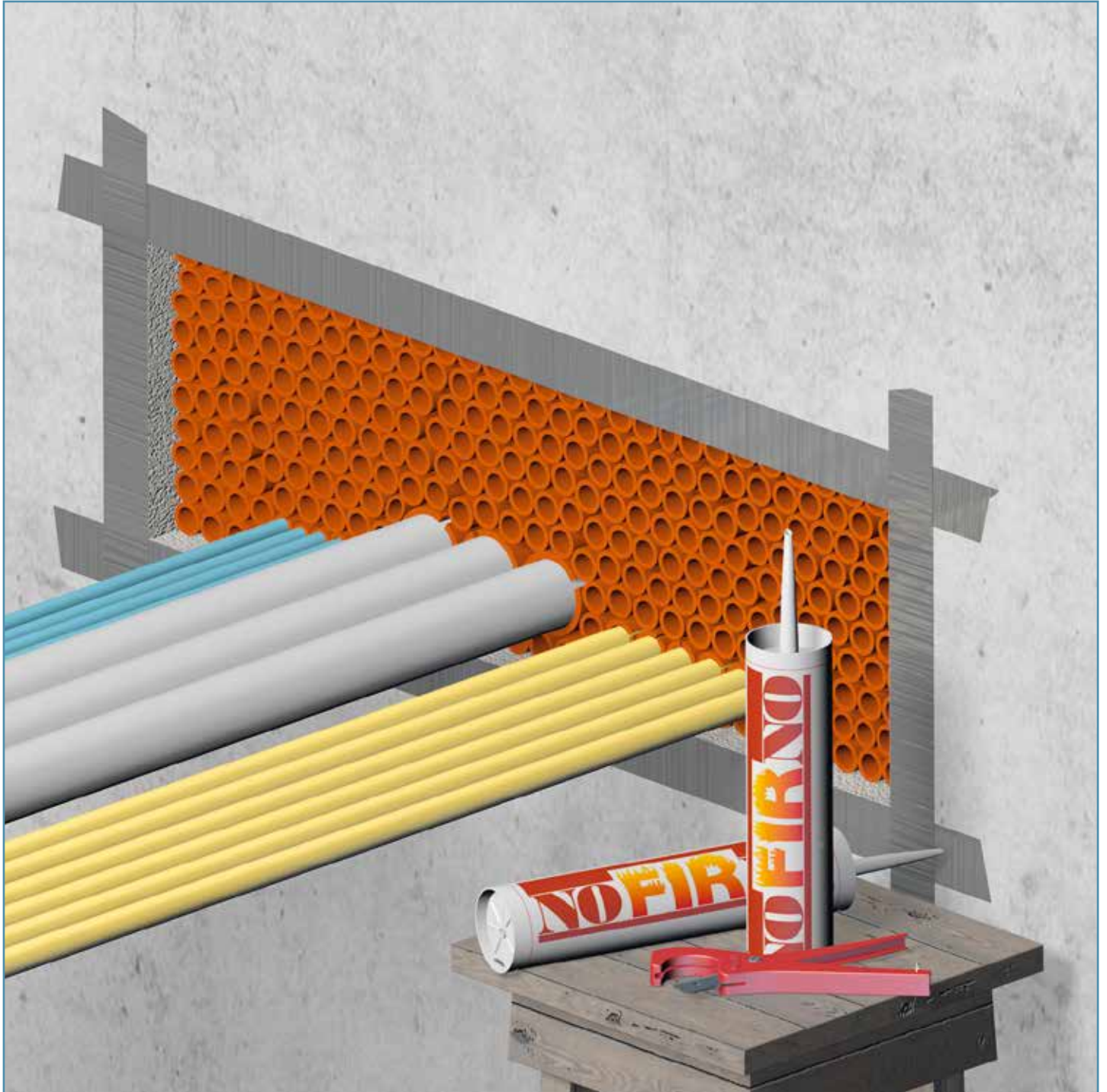

Final smoke, gas and watertight sealing of the NOFIRNO® multi-cable transits is achieved with the application of NOFIRNO® sealant. NOFIRNO® sealant has proven excellent performance with regard to mechanical and fire resistance requirements. The NOFIRNO® sealing system has been successfully exposed to severe pressure, shock and vibration tests.

## INSTALLATION INSTRUCTIONS FOR NOFIRNO® MULTI-CABLE TRANSIT SEALING SYSTEM



Cut the injection nozzles of the cartridges in an angled way to create a medium sized dispersing opening. This will improve the flow of the sealant in between the set of cables. Furthermore, it is advisable to use professional sealant guns. Hand fatigue is prevented, and an optimum flow of the sealant is obtained. For larger penetrations, electric or pneumatic dispensers should be used.

## INSTALLATION INSTRUCTIONS FOR NOFIRNO® MULTI-CABLE TRANSIT SEALING SYSTEM



A 20 mm thick layer of NOFIRNO® sealant is applied at each side of the NOFIRNO® multi-cable transit. NOFIRNO® sealant has an engineered viscosity, preventing the sealant from sagging and also allowing for a perfect flow of the sealant between the cables during injection. For multi-cable transits with a high filling rate, longer nozzles are available for the sealant cartridges.

Please refer to the Safety Data Sheet for more information about the working environment.

## INSTALLATION INSTRUCTIONS FOR NOFIRNO® MULTI-CABLE TRANSIT SEALING SYSTEM



Skin formation of the sealant takes place after ca. 10-15 minutes. In case of larger conduit dimensions with a low cable filling rate, do not apply more sealant than can be finished within this time-frame.

## INSTALLATION INSTRUCTIONS FOR NOFIRNO® MULTI-CABLE TRANSIT SEALING SYSTEM

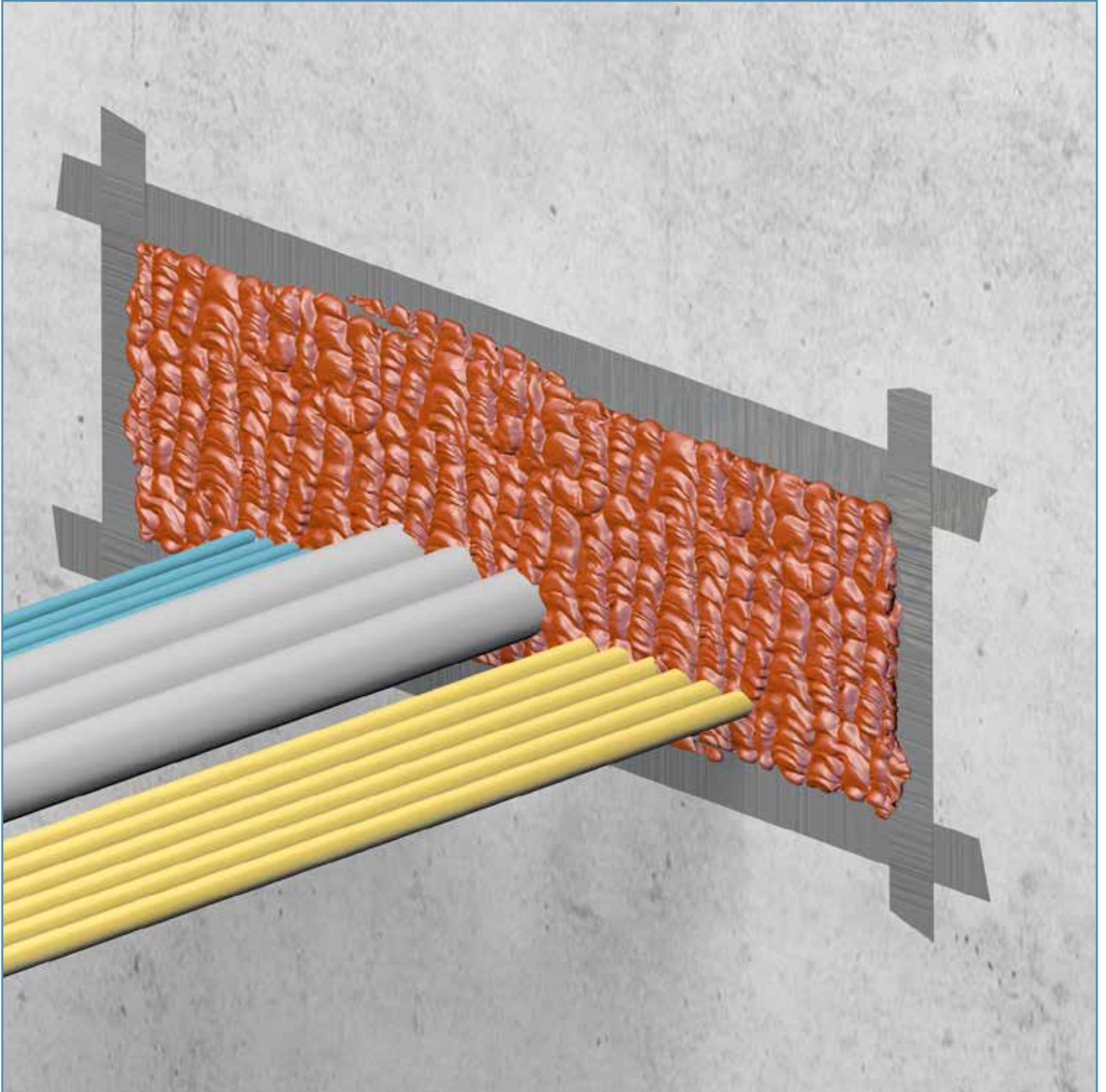

The multi-cable transit should be overfilled with NOFIRNO® sealant, because some sealant will be pushed into the empty spaces between the NOFIRNO® sleeves around the cables, and into the hollow NOFIRNO® (multi) filler sleeves during further finishing. This will contribute also to obtain higher tightness ratings.

## INSTALLATION INSTRUCTIONS FOR NOFIRNO® MULTI-CABLE TRANSIT SEALING SYSTEM



To smooth the surface of the NOFIRNO® sealant layer, a cloth is sprayed with water. This prevents the sealant from sticking to the cloth.

Please refer to the Safety Data Sheet for more information about the working environment.

## INSTALLATION INSTRUCTIONS FOR NOFIRNO® MULTI-CABLE TRANSIT SEALING SYSTEM

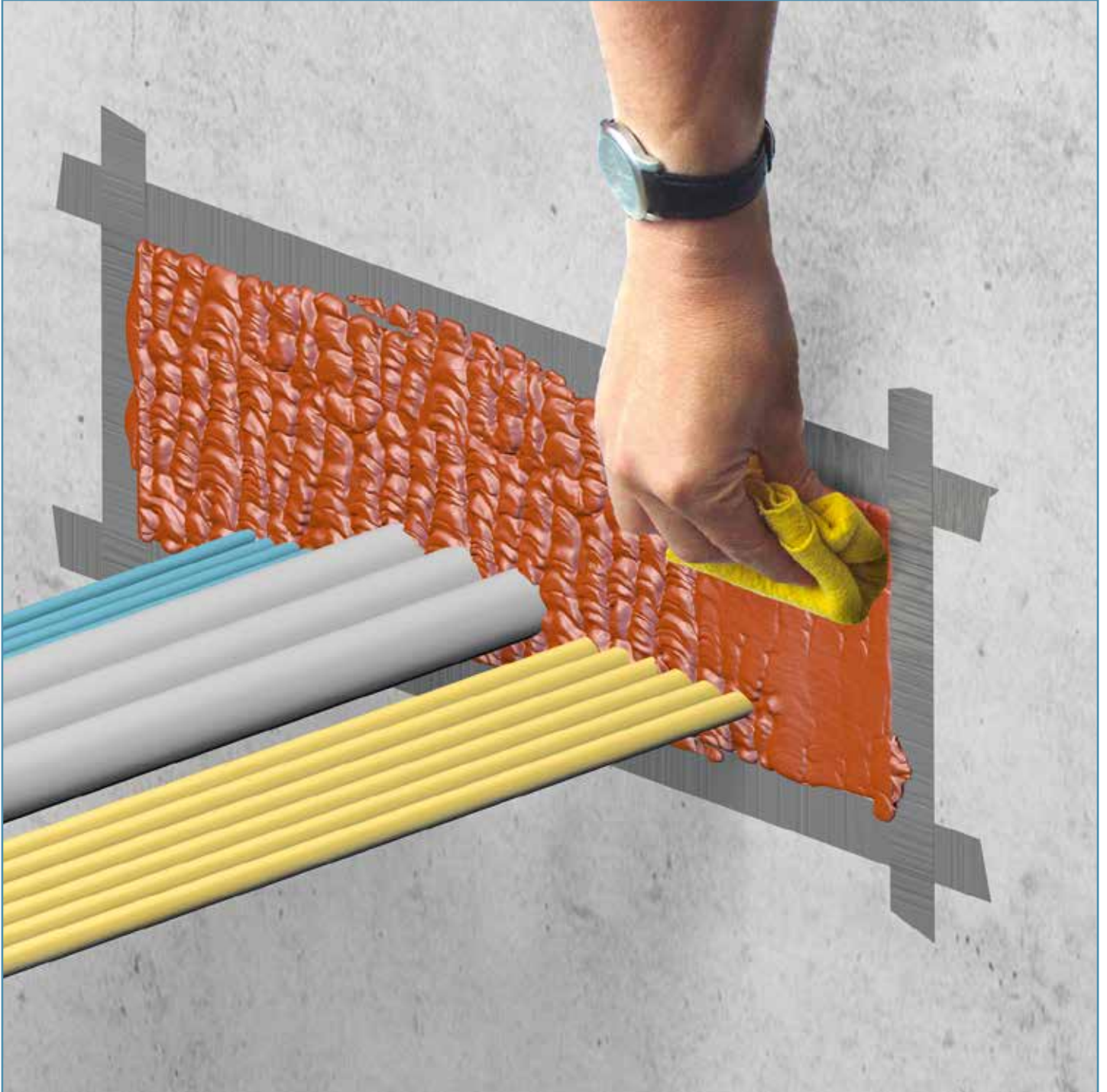

The cloth is then used to press down the sealant layer flush with the wall. It is of utmost importance to ensure that the sealant is compressed very tightly so that the sealant is pressed into all empty spaces of the NOFIRNO® sleeve set, including partially into the hollow filler sleeves. The larger the adhesive surfaces of the sealant, the higher the performance of the system.

## INSTALLATION INSTRUCTIONS FOR NOFIRNO® MULTI-CABLE TRANSIT SEALING SYSTEM

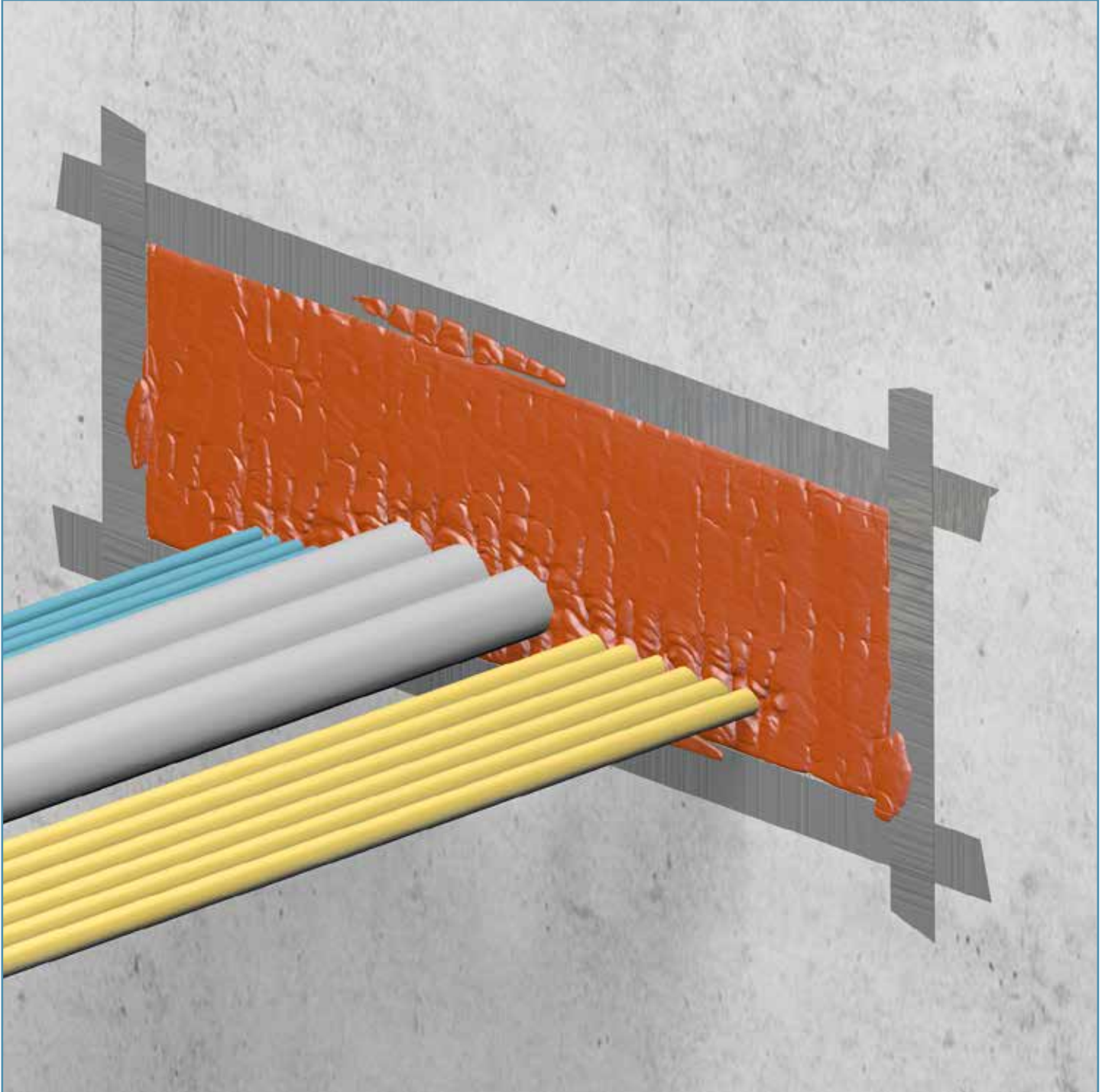

Due to the rapid skin formation of the sealant, smoothing should take place directly after compression of the sealant layer. As soon as skin formation has taken place, a very neat smoothing of the sealant layer is not possible anymore.

Note: the NOFIRNO® sealant is water repellent so that water will drip off. Neat smoothing is helpful in this respect. The NOFIRNO® sealant is also seawater, UV, ozone and weathering resistant, and offers a durability of decades.

## INSTALLATION INSTRUCTIONS FOR NOFIRNO® MULTI-CABLE TRANSIT SEALING SYSTEM

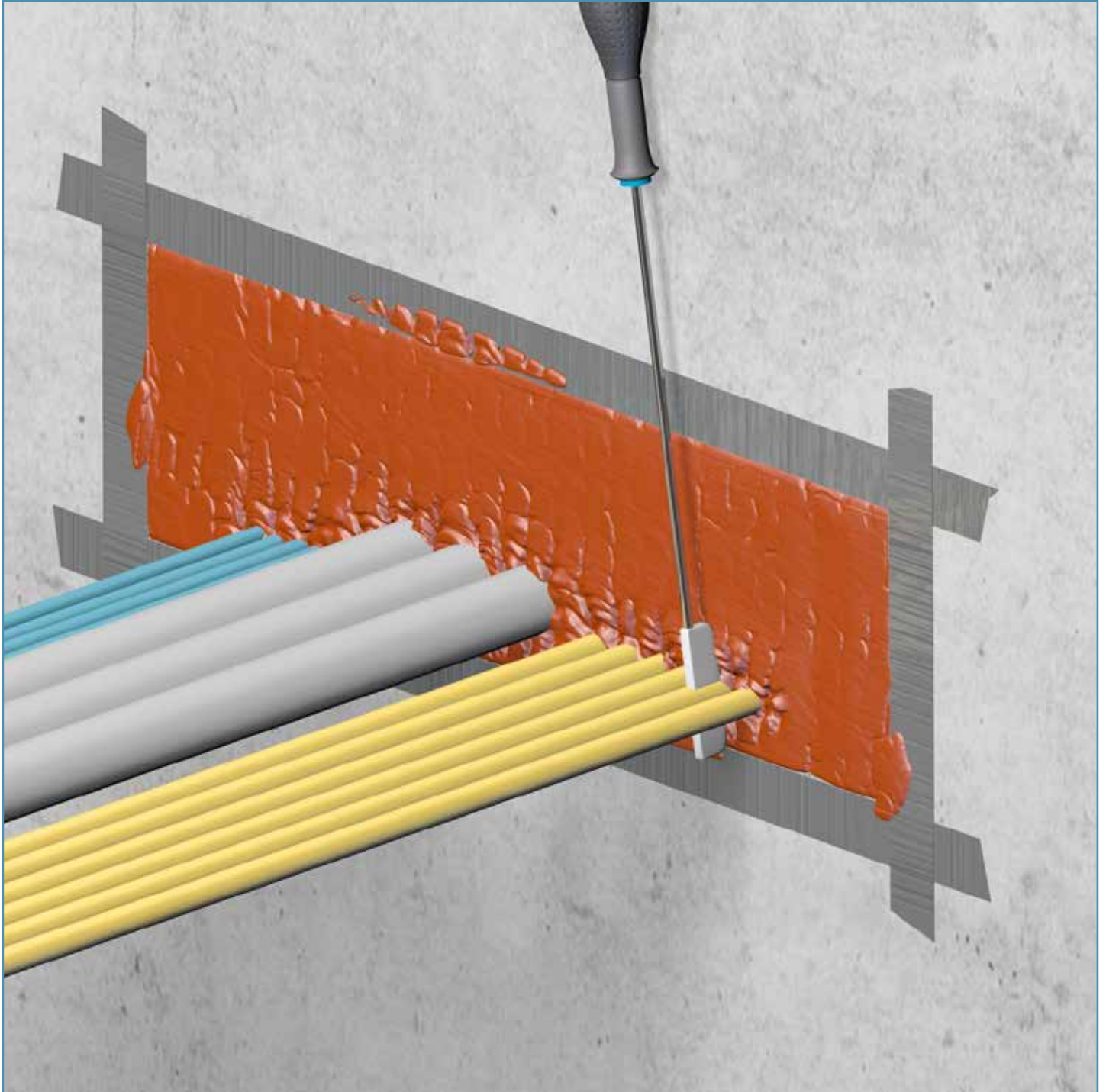

The NOFIRNO® sealant between the cables is pressed down and smoothed by hand or with a spatula or putty knife. A special tool, developed by BEELE Engineering, with a PTFE compression/smoothing part is available. The sealant will not stick to the PTFE.

Compression and smoothing, especially in between the cables, is essential to obtain an effective gas and water tightness.

## INSTALLATION INSTRUCTIONS FOR NOFIRNO® MULTI-CABLE TRANSIT SEALING SYSTEM

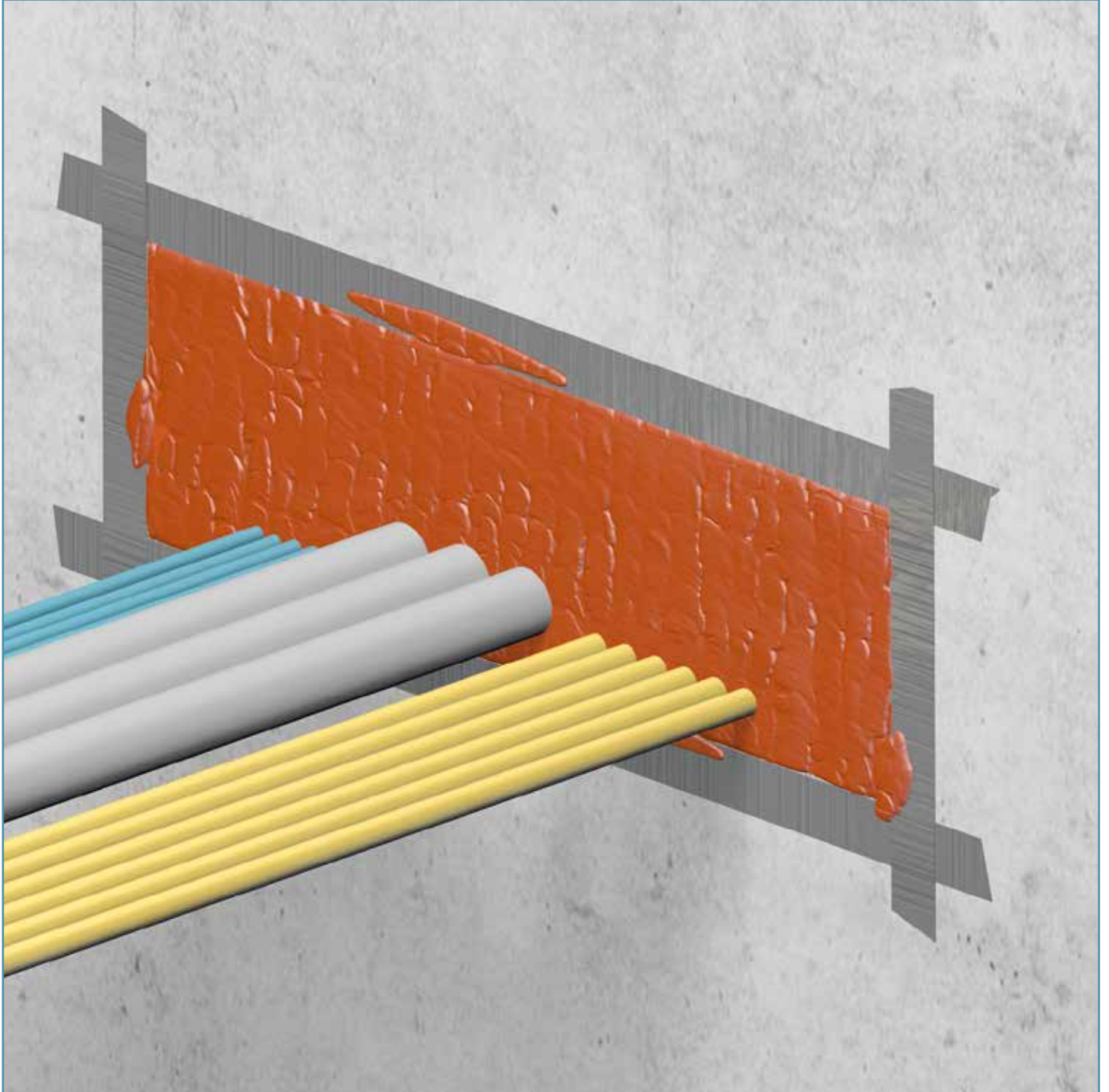

A last check should be made to ensure that the sealant layer is pressed down tightly and that no larger open holes are visible. Air enclosure within the individual layer of sealant should be prevented during finishing, because this would have a negative impact on the performance of the sealant layer under fire exposure.

Please refer to the Safety Data Sheet for more information about the working environment.

## INSTALLATION INSTRUCTIONS FOR NOFIRNO® MULTI-CABLE TRANSIT SEALING SYSTEM

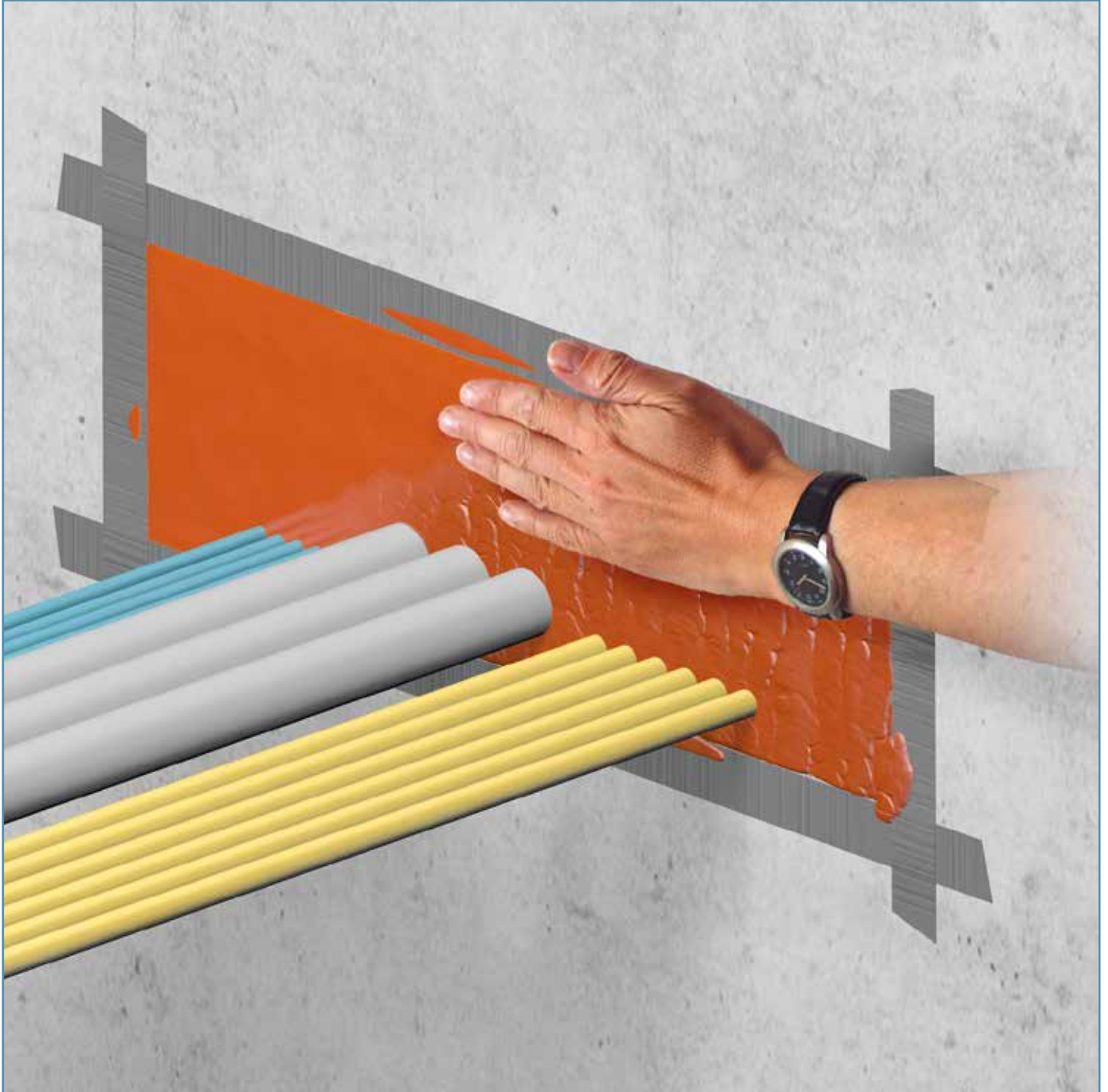

The surface can be smoothed by hand. Just wet the hands thoroughly with soap and water. No dirty hands when working with NOFIRNO® and a very neat surface is the result.  
Note: this should only be a smoothing procedure. Do not pack or compress the sealant further.

Wear protective gloves when working with NOFIRNO® sealant. Please refer to the Safety Data Sheet for more information

## INSTALLATION INSTRUCTIONS FOR NOFIRNO® MULTI-CABLE TRANSIT SEALING SYSTEM

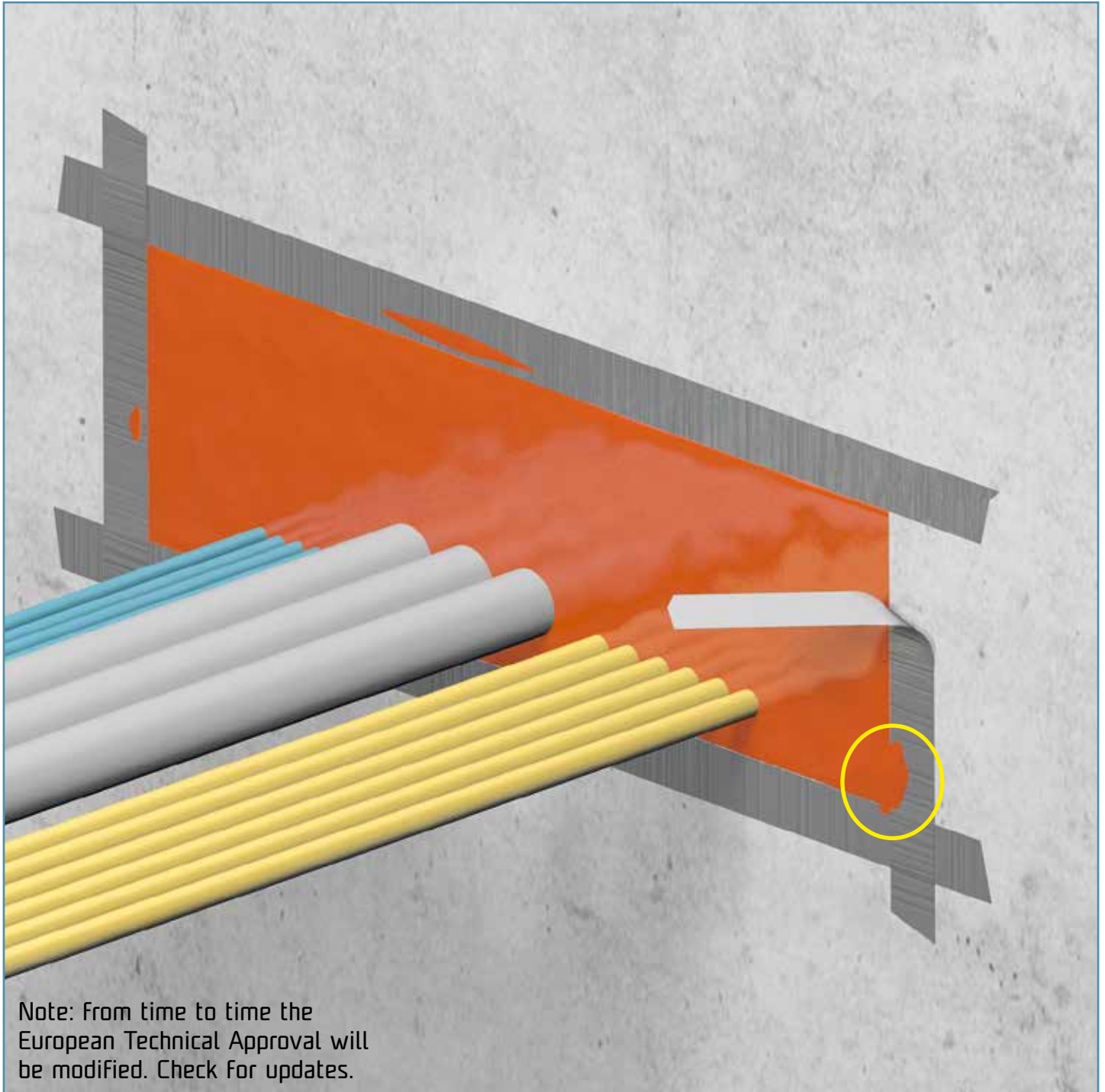

Directly after finishing the sealing system, the tape should be removed. Once the sealant is fully cured there will be no other option than to cut away the overlapping sealant due to the mechanical strength of the cured sealant. The wall will be clean and without any sealant residues.

The NOFIRNO® system has been successfully tested according to EN 1366-3:2009 for 4 hours in walls with a thickness of 100 mm, obtaining a fire classification of EI60/E240 and with a thickness of 150 mm, obtaining a fire classification of EI90/E240.

European Technical Approval 13-053 release February 27, 2017.

## INSTALLATION INSTRUCTIONS FOR NOFIRNO® MULTI-CABLE TRANSIT SEALING SYSTEM

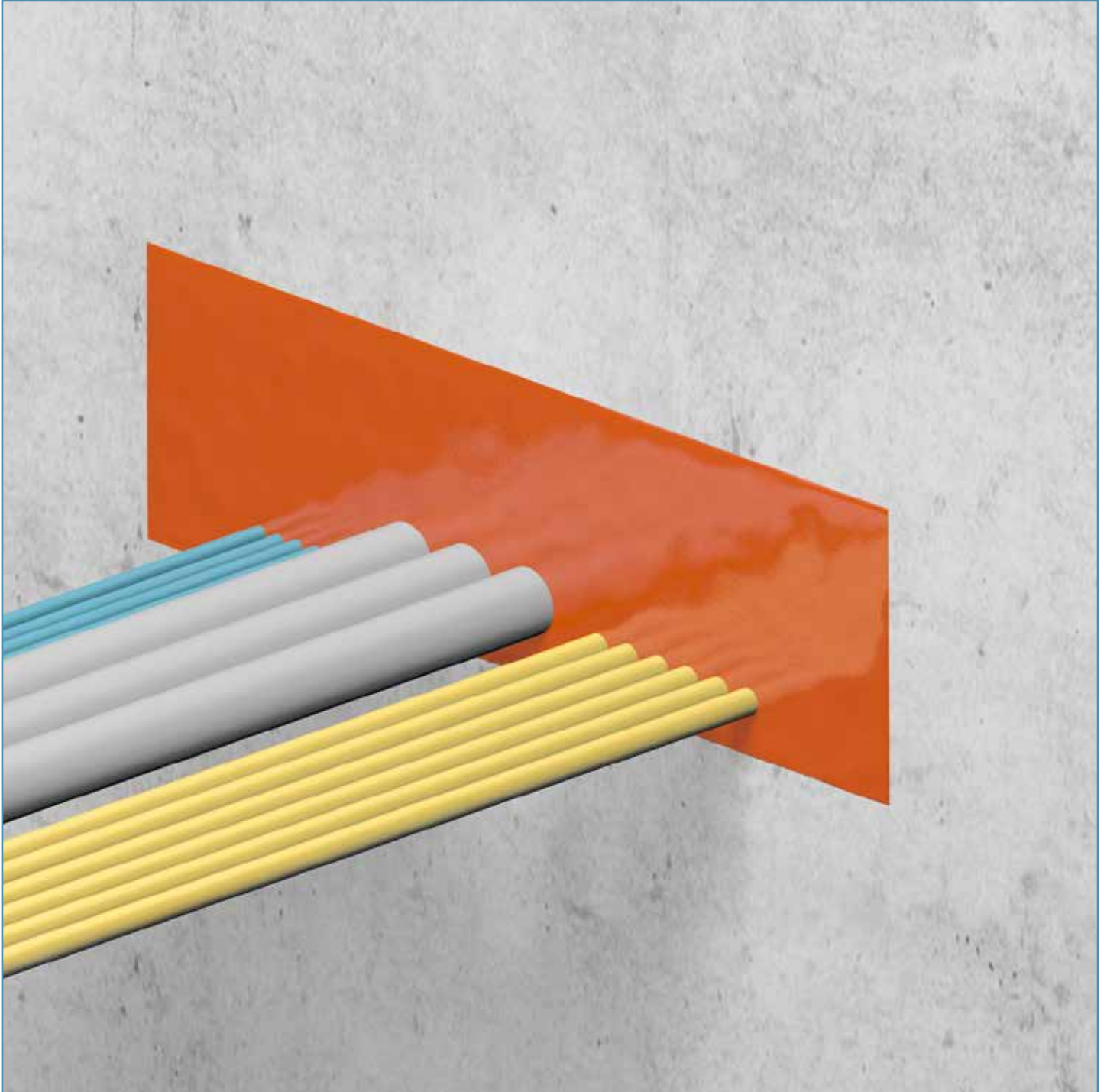

To obtain optimum adhesion during the curing process of the sealant, all the cables should be tightly fixed at both sides of the transit, as close as possible to the transit, and immediately after finishing the transit. Movement of the cables during the curing process will impair the adhesion process to the cable sheathings.

Note: time needed for curing of the sealant is dependent on air humidity in combination with the environmental temperature. It is advisable to place a sticker near the finished transit, stating that the transit has been recently installed, and should not be touched or damaged.

## INSTALLATION INSTRUCTIONS FOR NOFIRNO® MULTI-CABLE TRANSIT SEALING SYSTEM

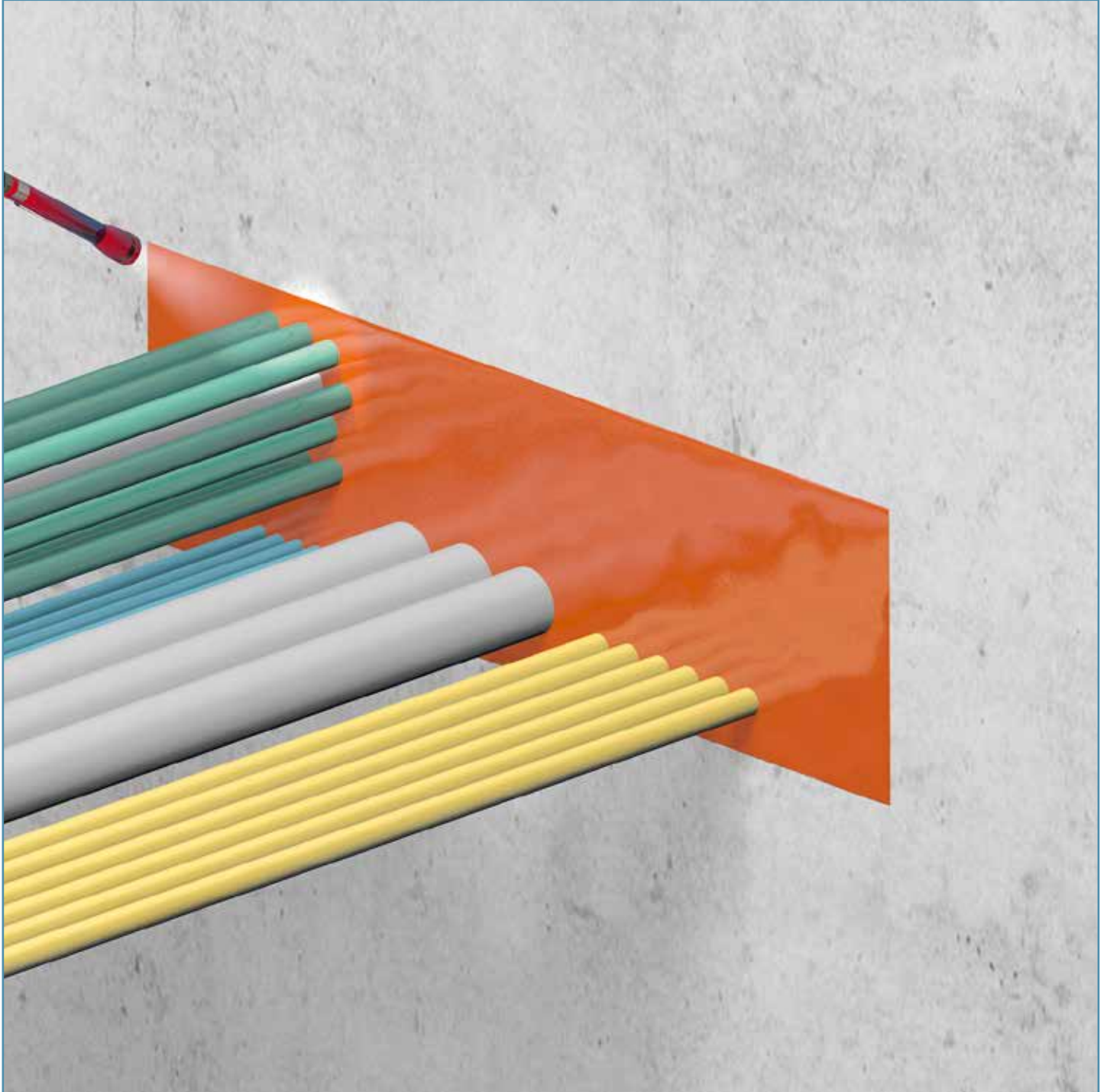

Additional information: applying the sealant on highly filled multi-cable transits can be quite complicated.

The sealant can be applied in layers from the bottom to the top after cable pulling. Regardless, checking if sufficient sealant is applied in between sets of cables close to each other is a must. The reflective colour of the NOFIRNO® has the advantage that visual inspection of the sealant application in between cables is easier to perform.

Water and gas tightness is dependent on the quality of the final sealing. As is the case with any system, workmanship has a direct impact on the performance of the sealing system.

## INSTALLATION INSTRUCTIONS FOR NOFIRNO® MULTI-CABLE TRANSIT SEALING SYSTEM

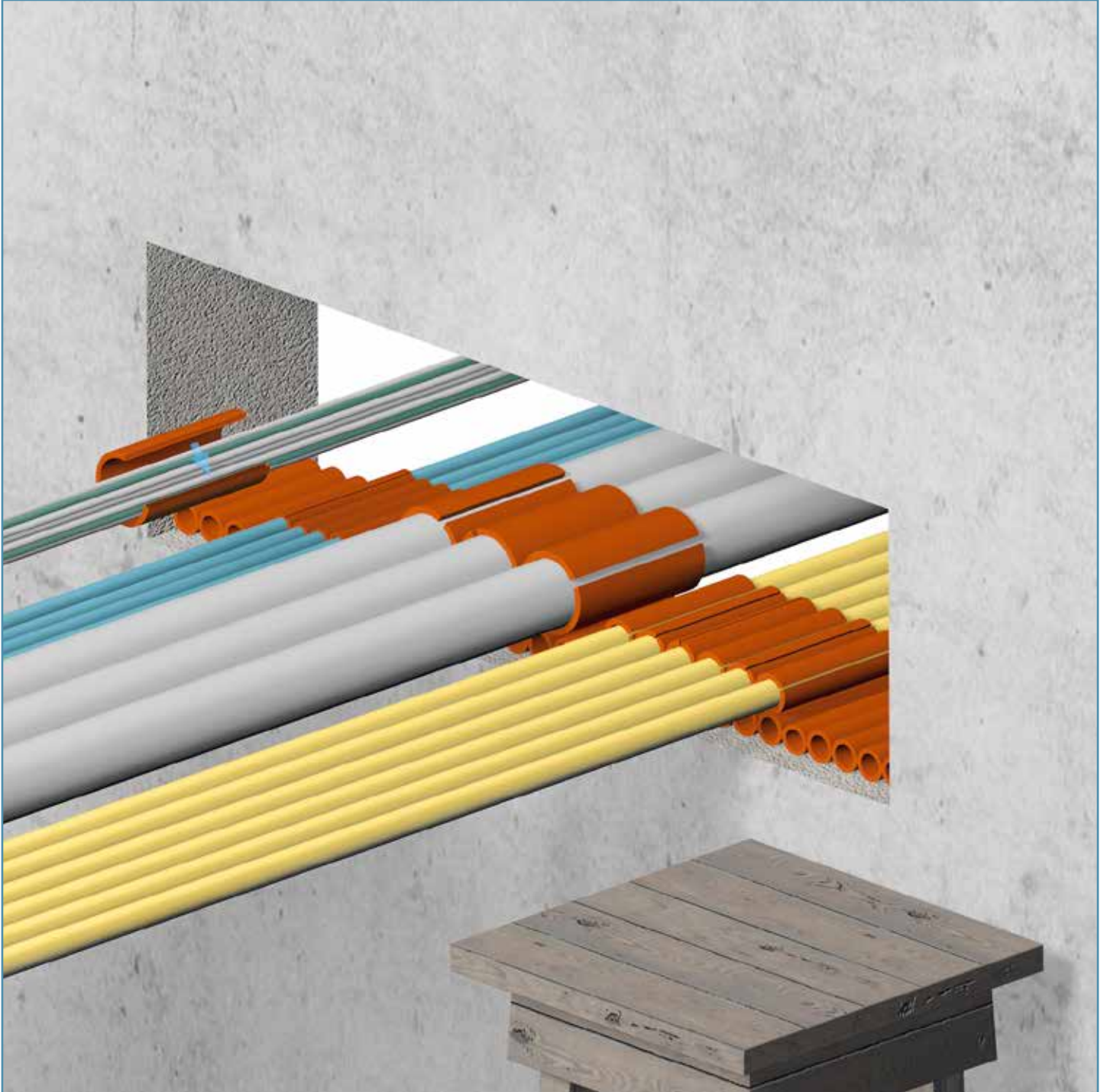

Additional information: bundled cable sets are allowed in the NOFIRNO® multi-cable sealing system, using only a single NOFIRNO® cable insert sleeve around the bundle of cables. Note: Bundling is limited to approved maximum dimensions.

## INSTALLATION INSTRUCTIONS FOR NOFIRNO® MULTI-CABLE TRANSIT SEALING SYSTEM

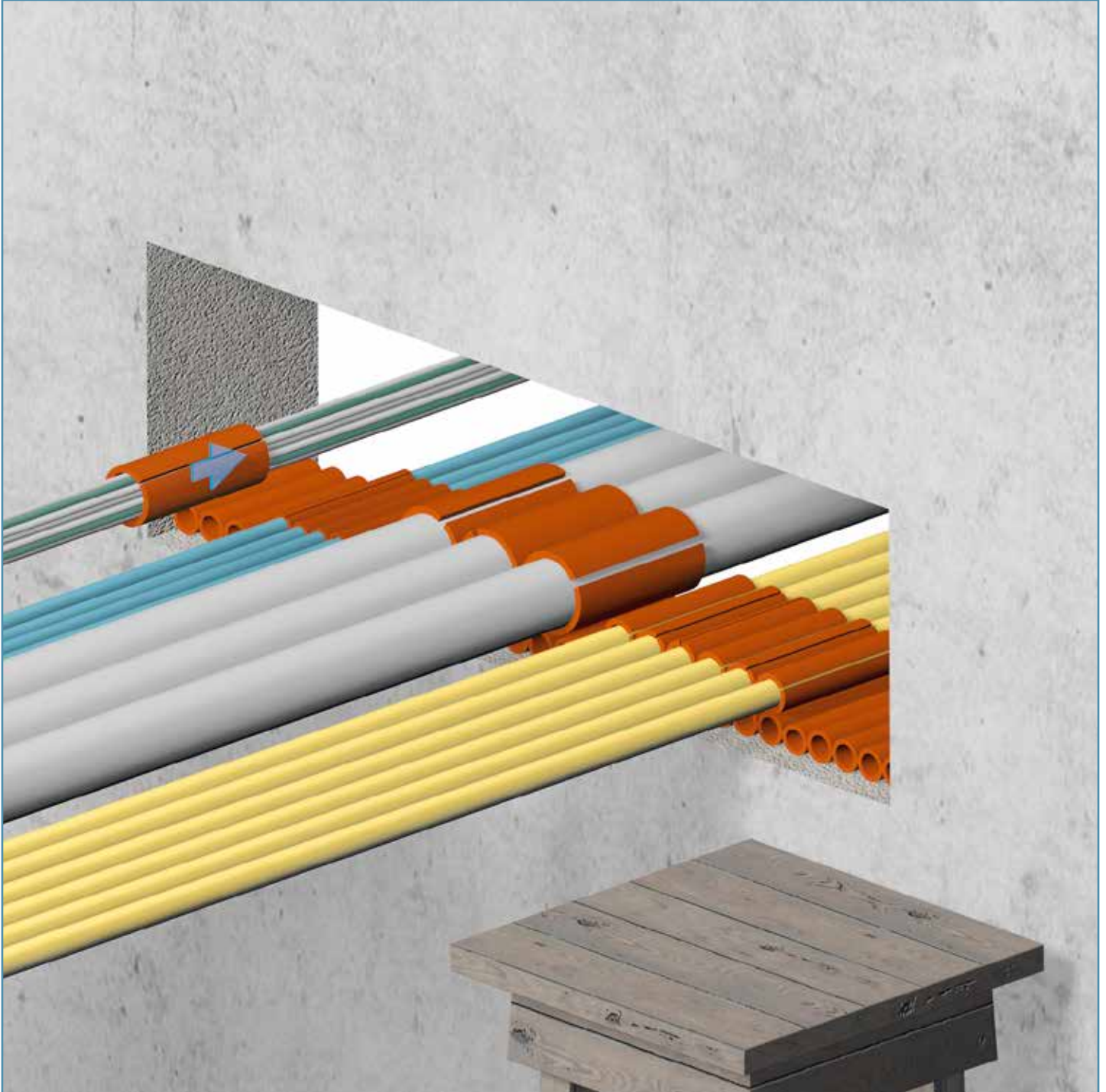

The cable insert sleeve is then pushed into the transit leaving 20 mm free at front and backside.

Note: NOFIRNO® multi-cable transits with bundled cables are not approved for watertight partitions.

## INSTALLATION INSTRUCTIONS FOR NOFIRNO® MULTI-CABLE TRANSIT SEALING SYSTEM

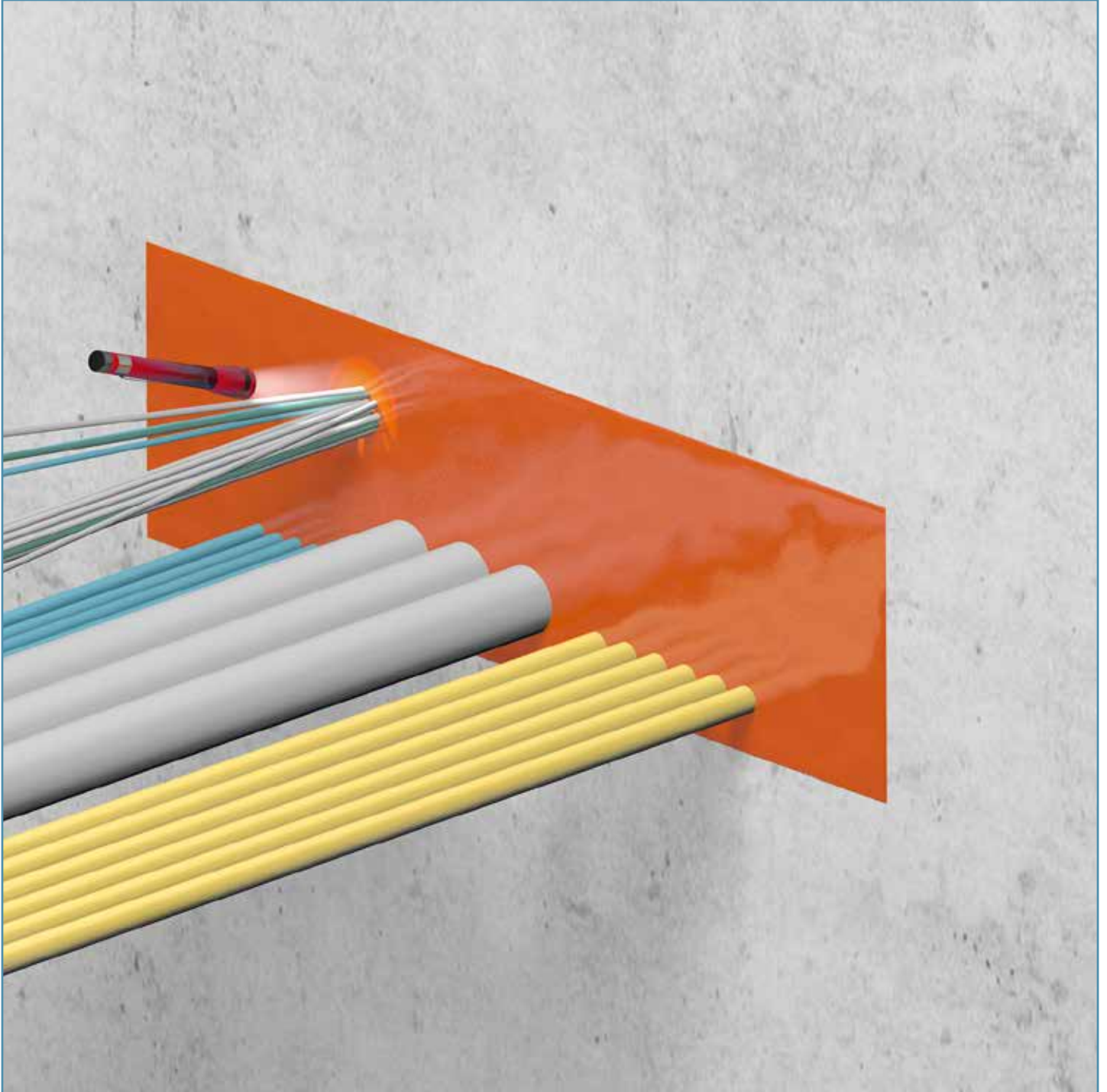

Check for all certainty that the sealant has been well packed around the bundle of cables in order to ensure an appropriate degree of cold smoke tightness.

## INSTALLATION INSTRUCTIONS FOR NOFIRNO® MULTI-CABLE TRANSIT SEALING SYSTEM

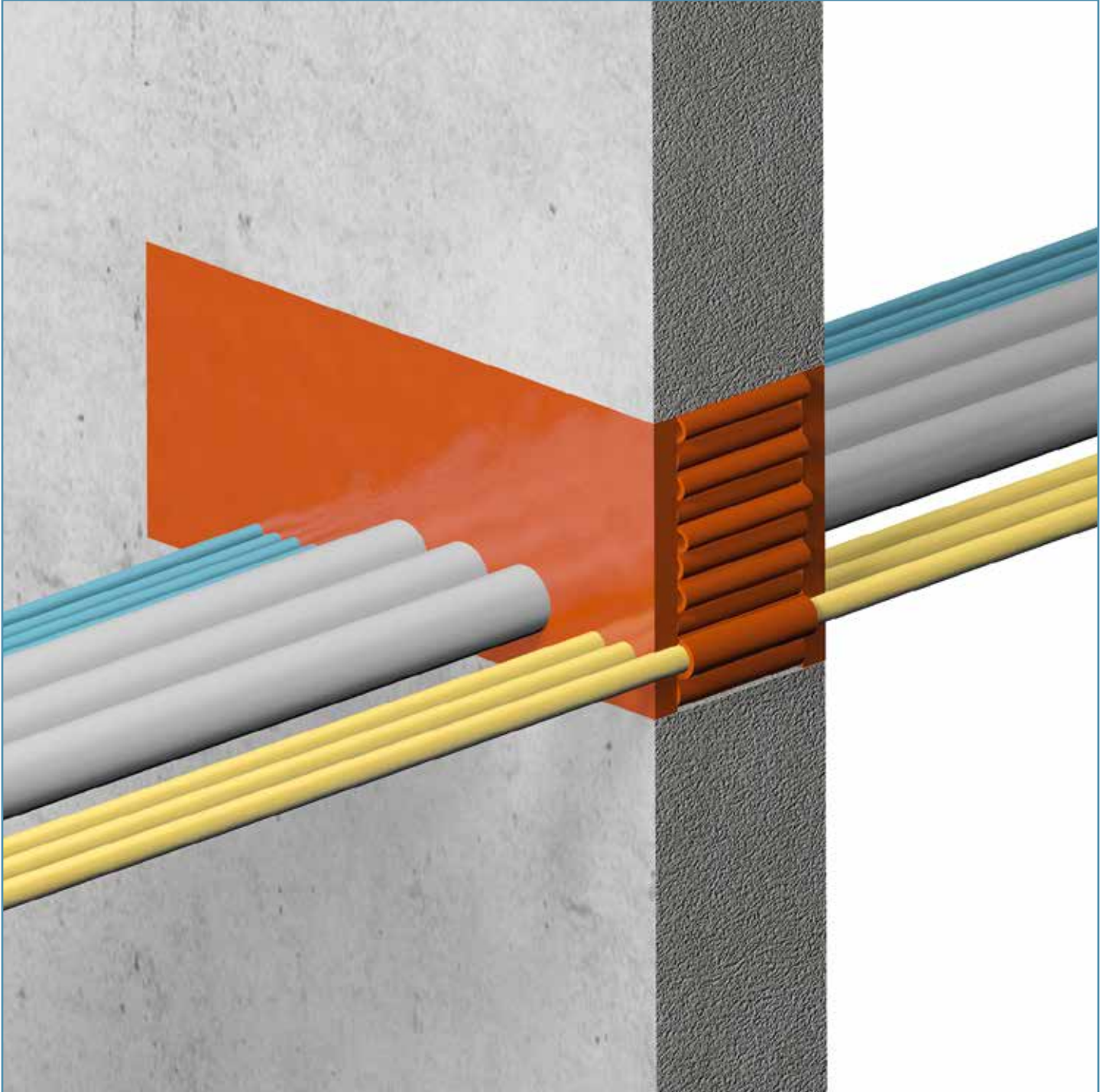

The NOFIRNO rubber grade of the sleeves and the NOFIRNO® sealant are suitable for gas and water-, tight ducting, and for fire rated applications as well. The NOFIRNO® rubber and sealant stay flexible at temperatures of -50 °C, allowing application in arctic environments. The NOFIRNO® multi-cable transits have excellent resistance to seawater, UV, ozone and weather. Based on the use of the high tech silicone composition of the NOFIRNO® rubber and sealant, the system offers excellent durability. The NOFIRNO® rubber is highly endothermic and will not be consumed by the fire. No metal parts are incorporated in the sealing system. No corrosion will occur.

## INSTALLATION INSTRUCTIONS FOR NOFIRNO® MULTI-CABLE TRANSIT SEALING SYSTEM (FLOOR)

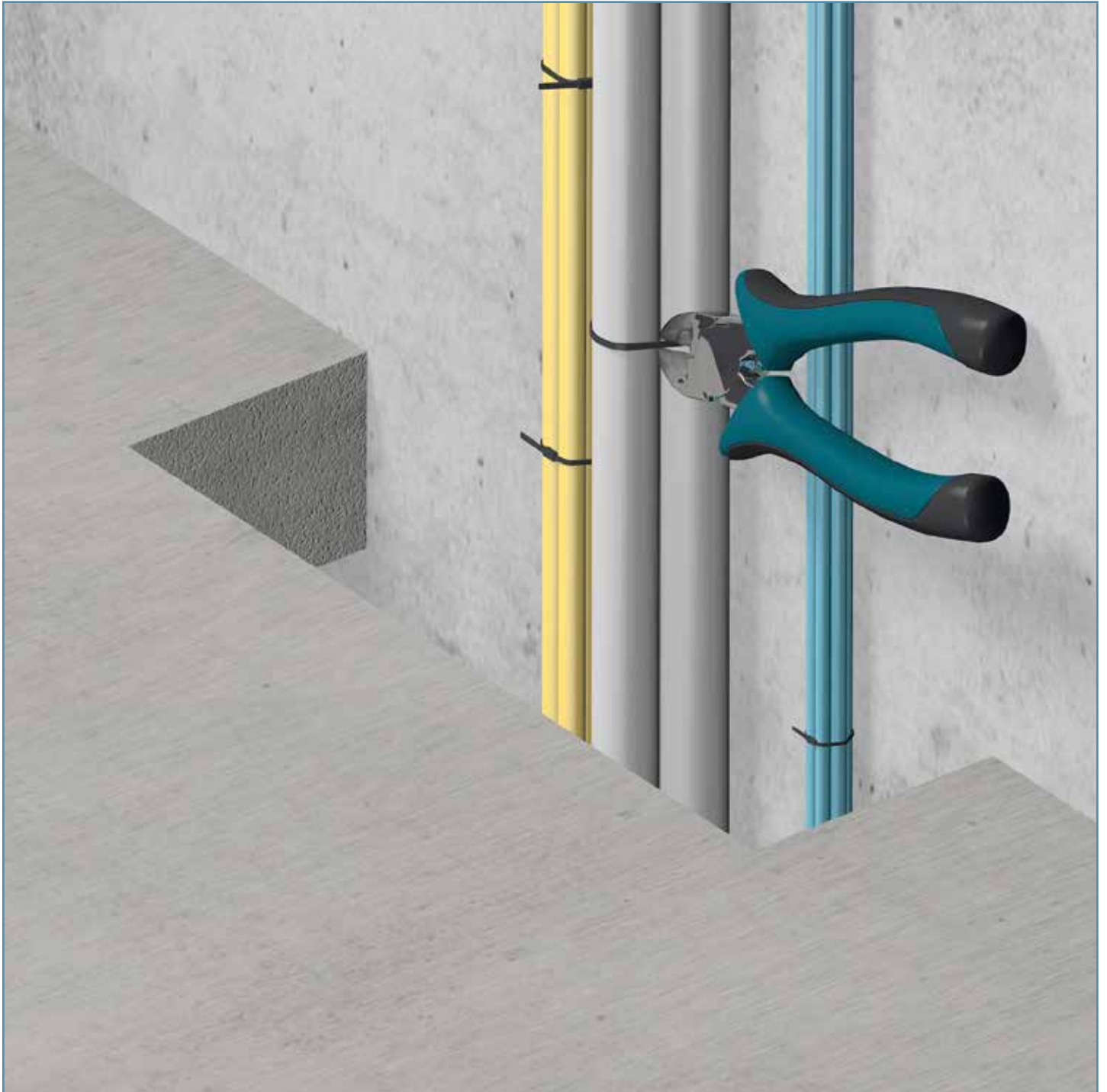

Floor penetrations are also easy to install with the NOFIRNO® system. Remove any cable tie-wraps to provide sufficient play of the cable set.

## INSTALLATION INSTRUCTIONS FOR NOFIRNO® MULTI-CABLE TRANSIT SEALING SYSTEM (FLOOR)

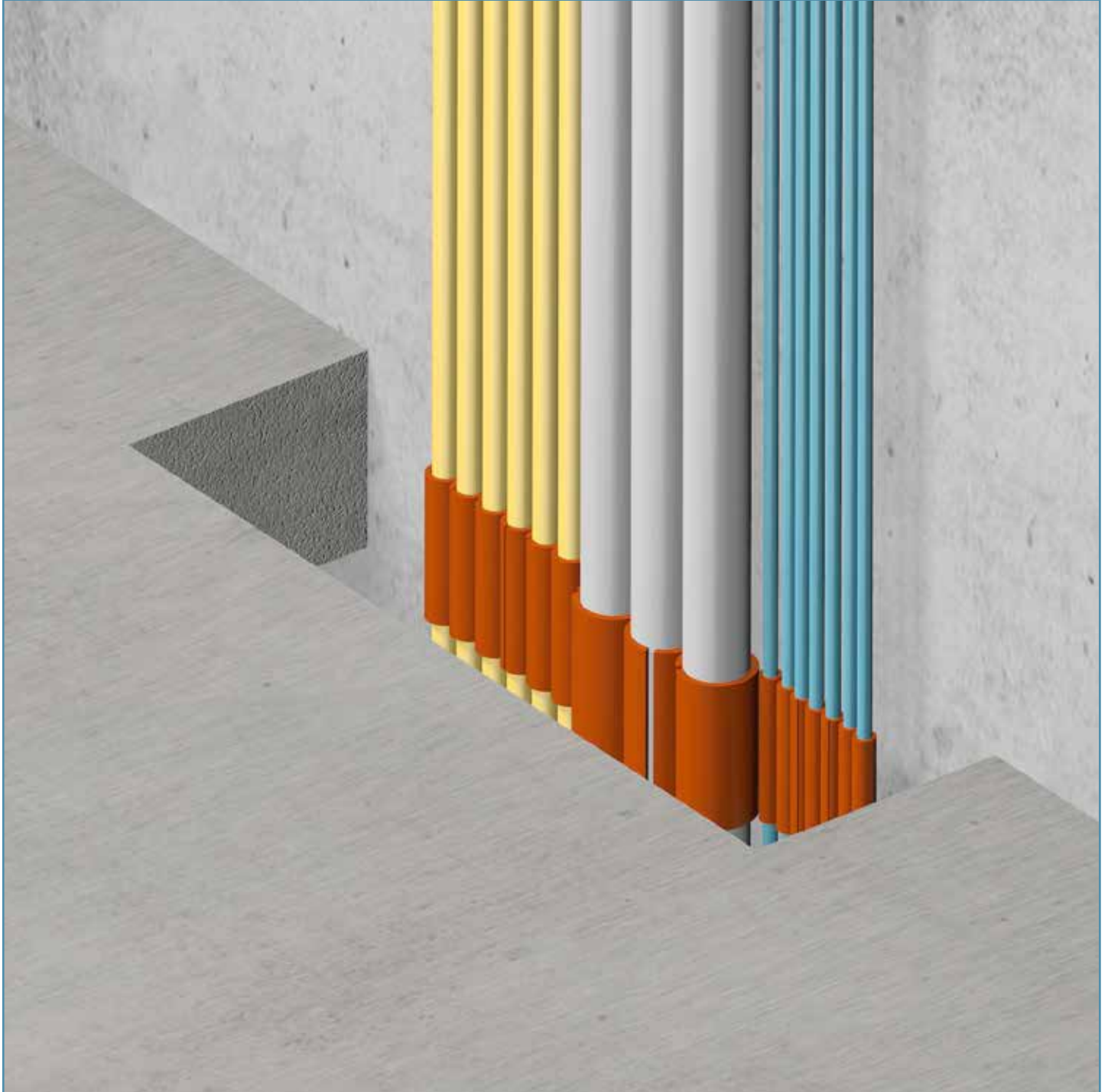

To prevent the NOFIRNO® cable insert sleeves from sliding down the cables, the sleeves should be a bit undersized to the cable. This allows the sleeves to cling to the cables, preventing them from sliding down.

## INSTALLATION INSTRUCTIONS FOR NOFIRNO® MULTI-CABLE TRANSIT SEALING SYSTEM (FLOOR)

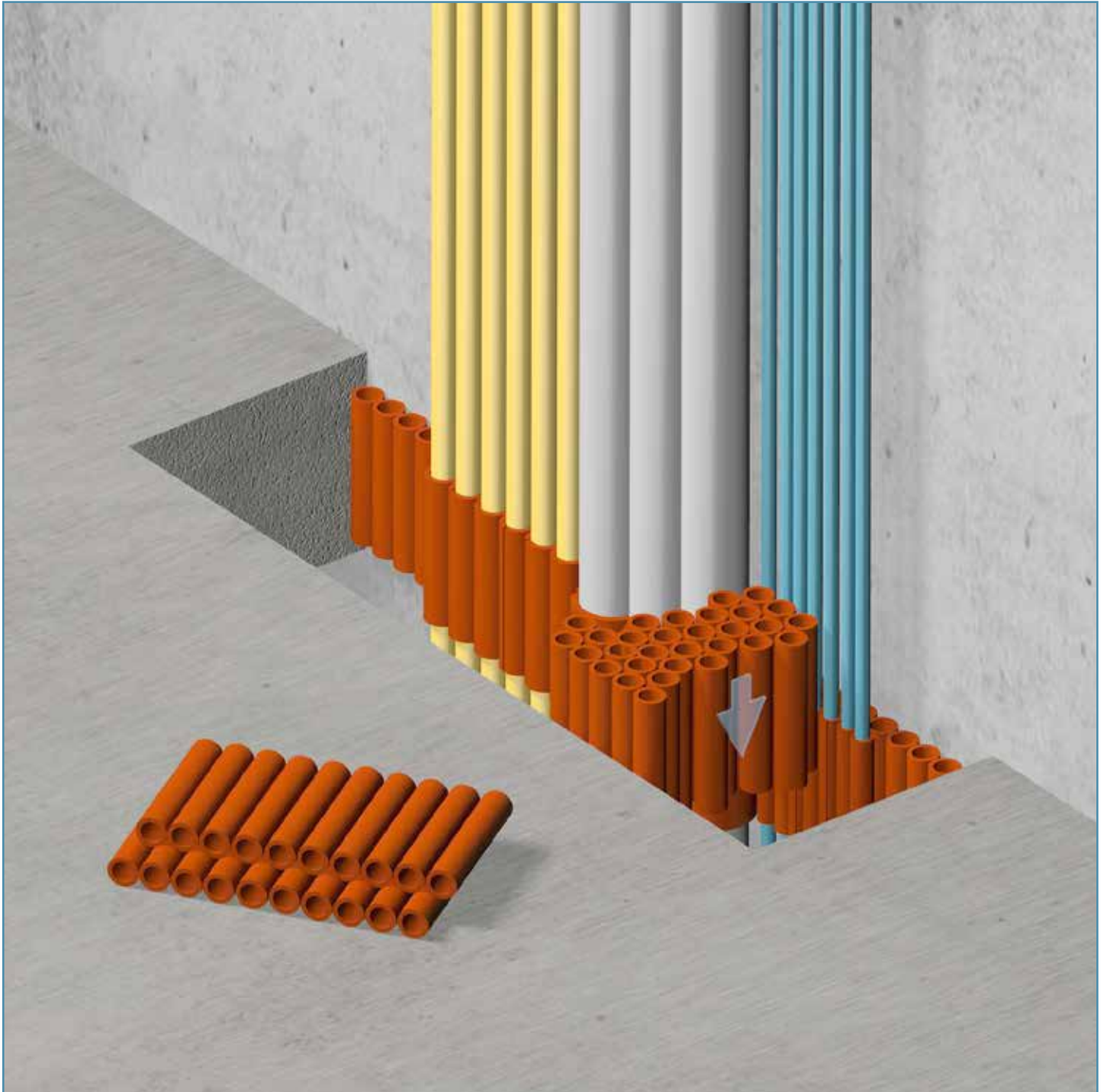

By making use of the NOFIRNO® multi-filler sleeves, sets and bundles can be made to ensure tight fitting inside the conduit opening. With NOFIRNO® single filler sleeves, the filling of larger floor conduits will be more difficult.

Based on the flexibility and compression set of the NOFIRNO® rubber the clamping forces of the NOFIRNO® multi-filler sleeves is high enough to prevent them from falling down.

## INSTALLATION INSTRUCTIONS FOR NOFIRNO® MULTI-CABLE TRANSIT SEALING SYSTEM (FLOOR)

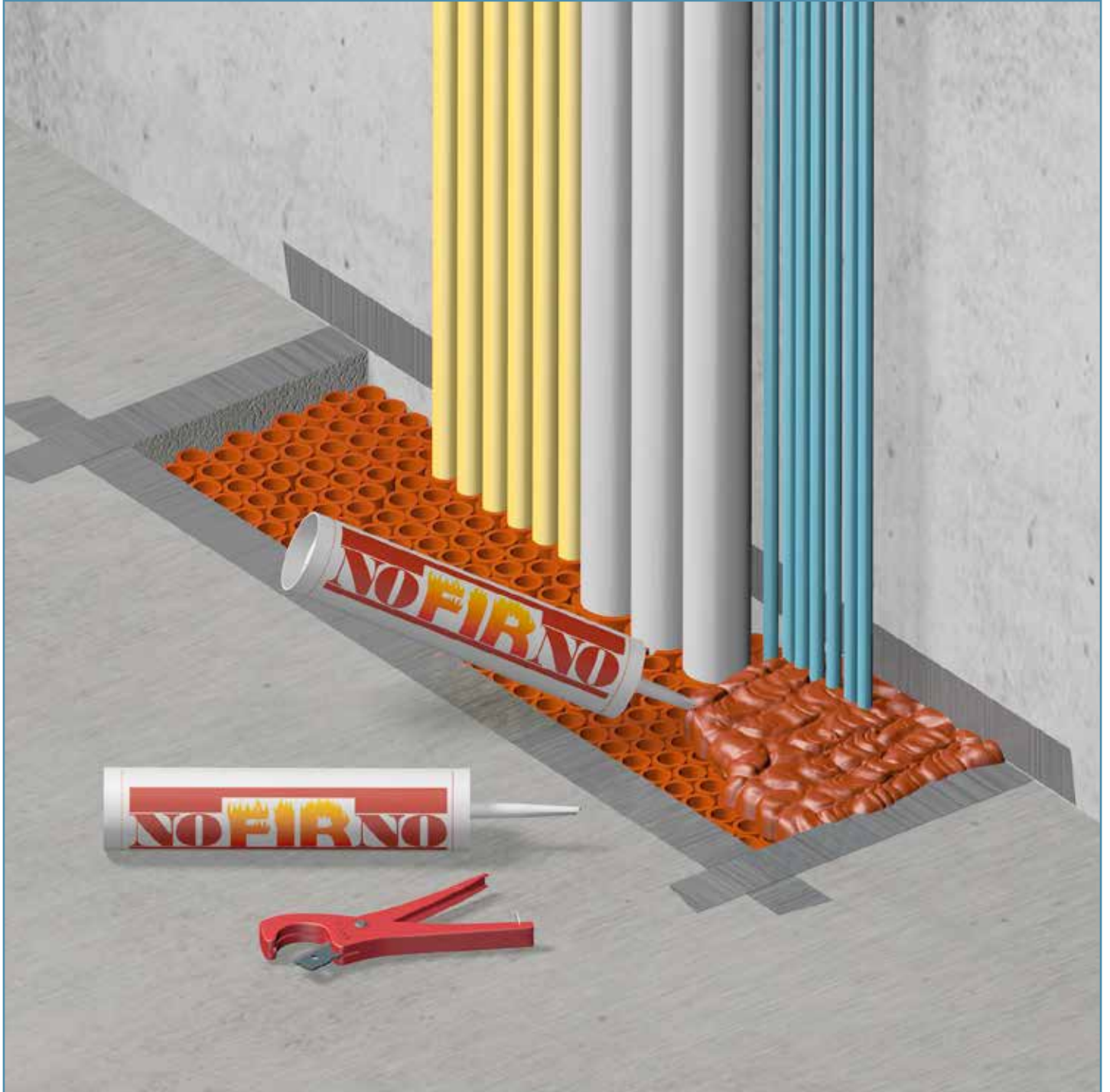

With the Beele® adjuster or a marked piece of wood, the set of fillers is adjusted inside the transit. The surrounding surfaces of the conduit opening are taped and then the NOFIRNO® sealant is applied in the same way as for wall conduits.

Please refer to the Safety Data Sheet for more information about the working environment.

## INSTALLATION INSTRUCTIONS FOR NOFIRNO® MULTI-CABLE TRANSIT SEALING SYSTEM (FLOOR)

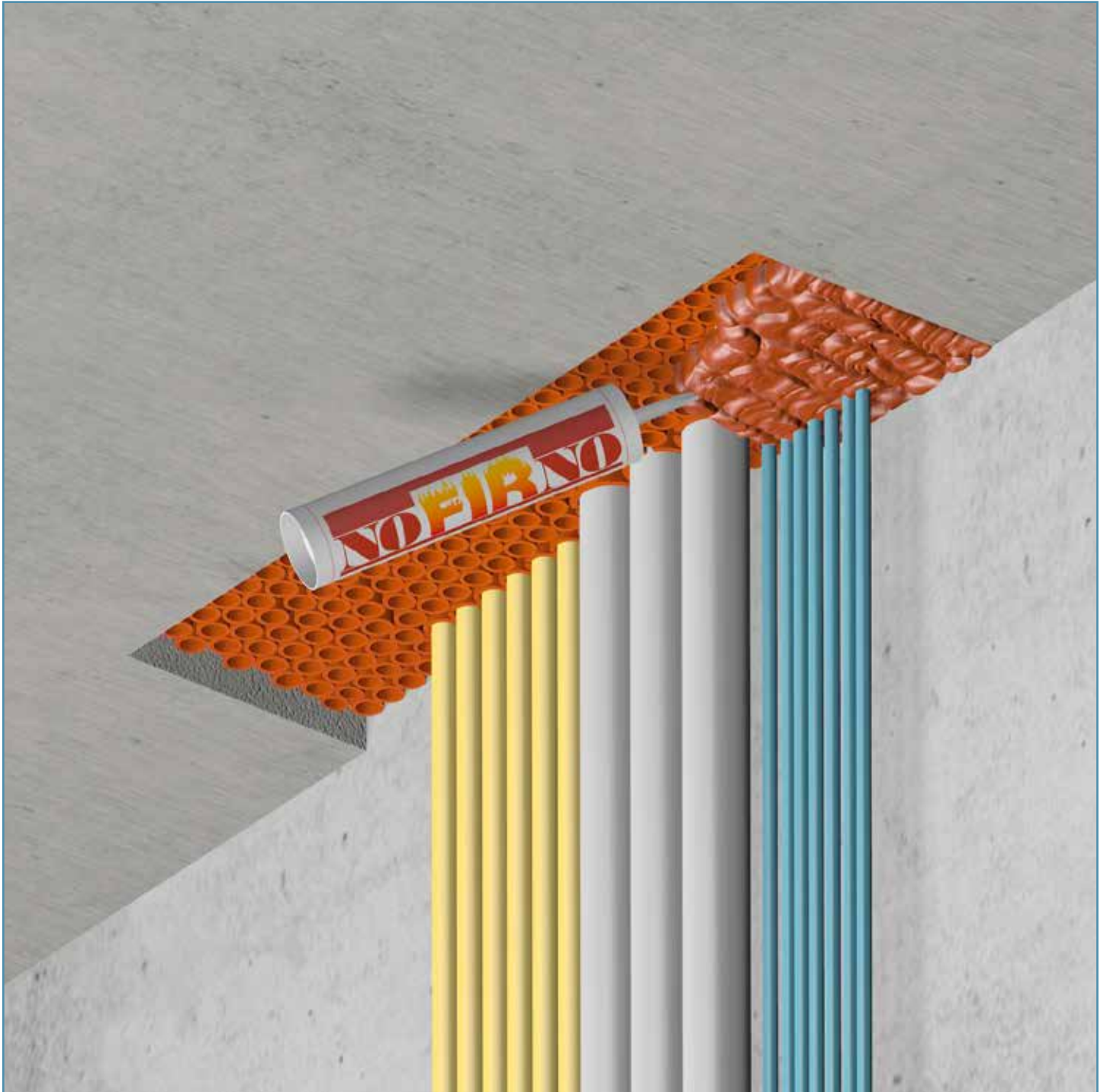

The NOFIRNO® sealant can be applied overhead for floor conduits without dripping or sagging. For cable transits with a high filling rate, longer nozzles for the sealant cartridges are available.

## INSTALLATION INSTRUCTIONS FOR NOFIRNO® MULTI-CABLE TRANSIT SEALING SYSTEM (FLOOR)

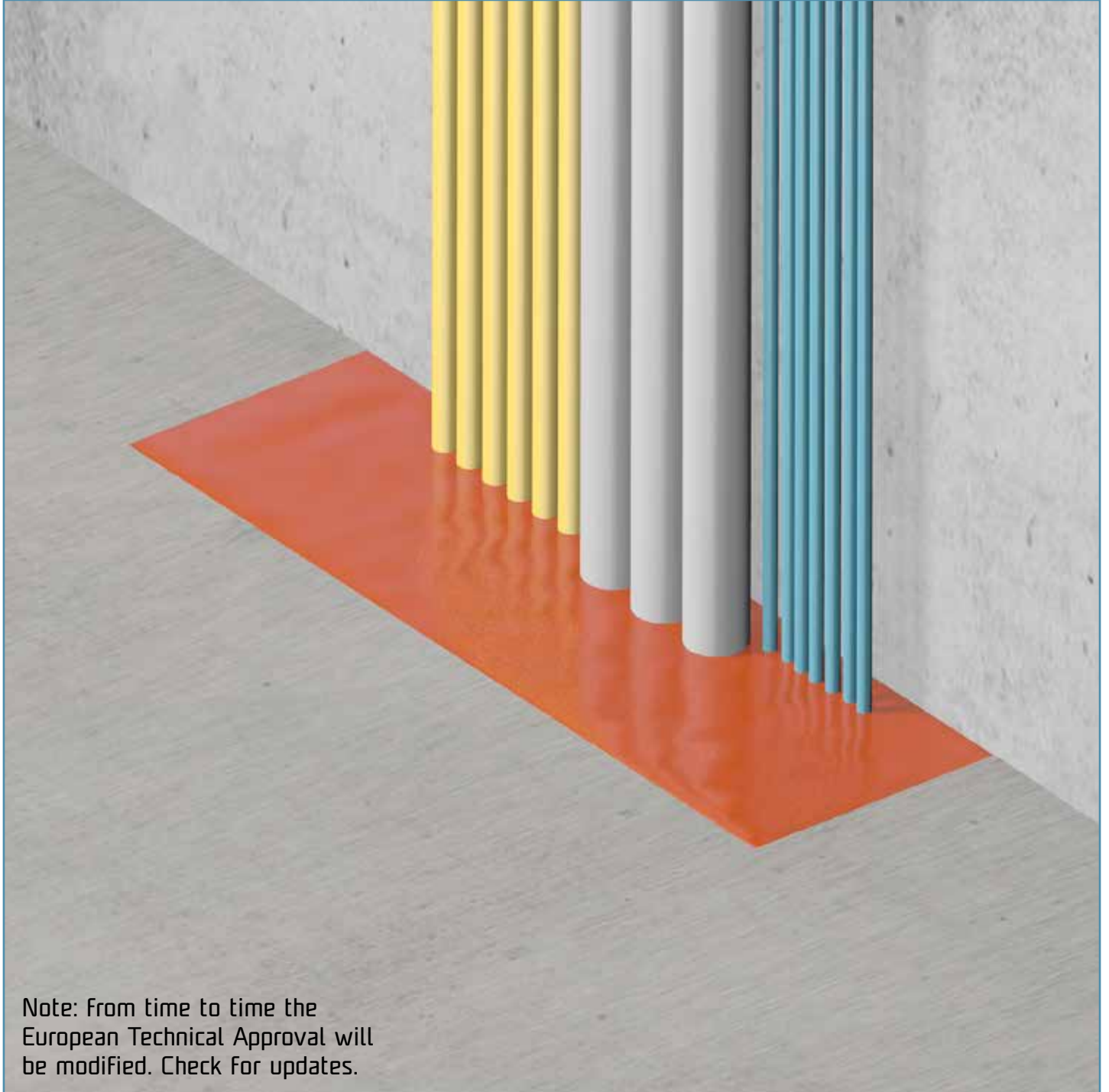

Note: From time to time the European Technical Approval will be modified. Check for updates.

The NOFIRNO system has been successfully tested according to EN 1366-3:2009 for two hours in floors with a thickness of 150 mm and obtained a fire classification of EI90/E120. European Technical Approval 13-053 release February, 2017.

## INSTALLATION INSTRUCTIONS FOR NOFIRNO® MULTI-CABLE TRANSIT SEALING SYSTEM (FLOOR)

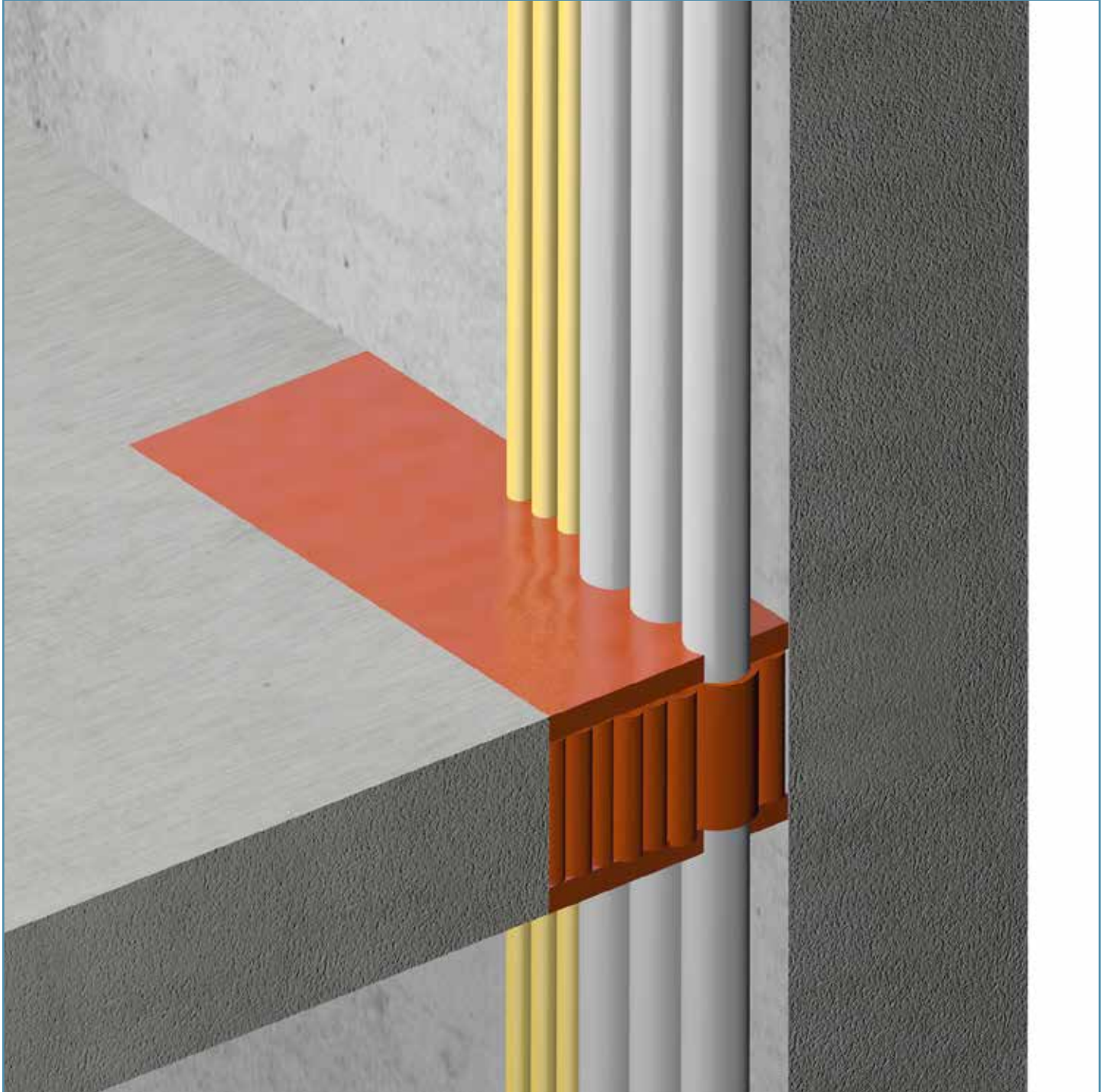

The NOFIRNO rubber grade of the sleeves and the NOFIRNO® sealant are suitable for gas and water-tight ducting, and for fire rated applications as well. The NOFIRNO® rubber and sealant stay flexible at temperatures of -50 °C, allowing application in arctic environments. The NOFIRNO® multi-cable transits have excellent resistance to seawater, UV, ozone and weather. Based on the use of the high tech silicone composition of the NOFIRNO® rubber and sealant, the system offers excellent durability. The NOFIRNO® rubber is highly endothermic and will not be consumed by the fire. No metal parts are incorporated in the sealing system. No corrosion will occur.

## INSTALLATION INSTRUCTIONS FOR NOFIRNO® MULTI-CABLE TRANSIT SEALING SYSTEM (ADDING CABLE)

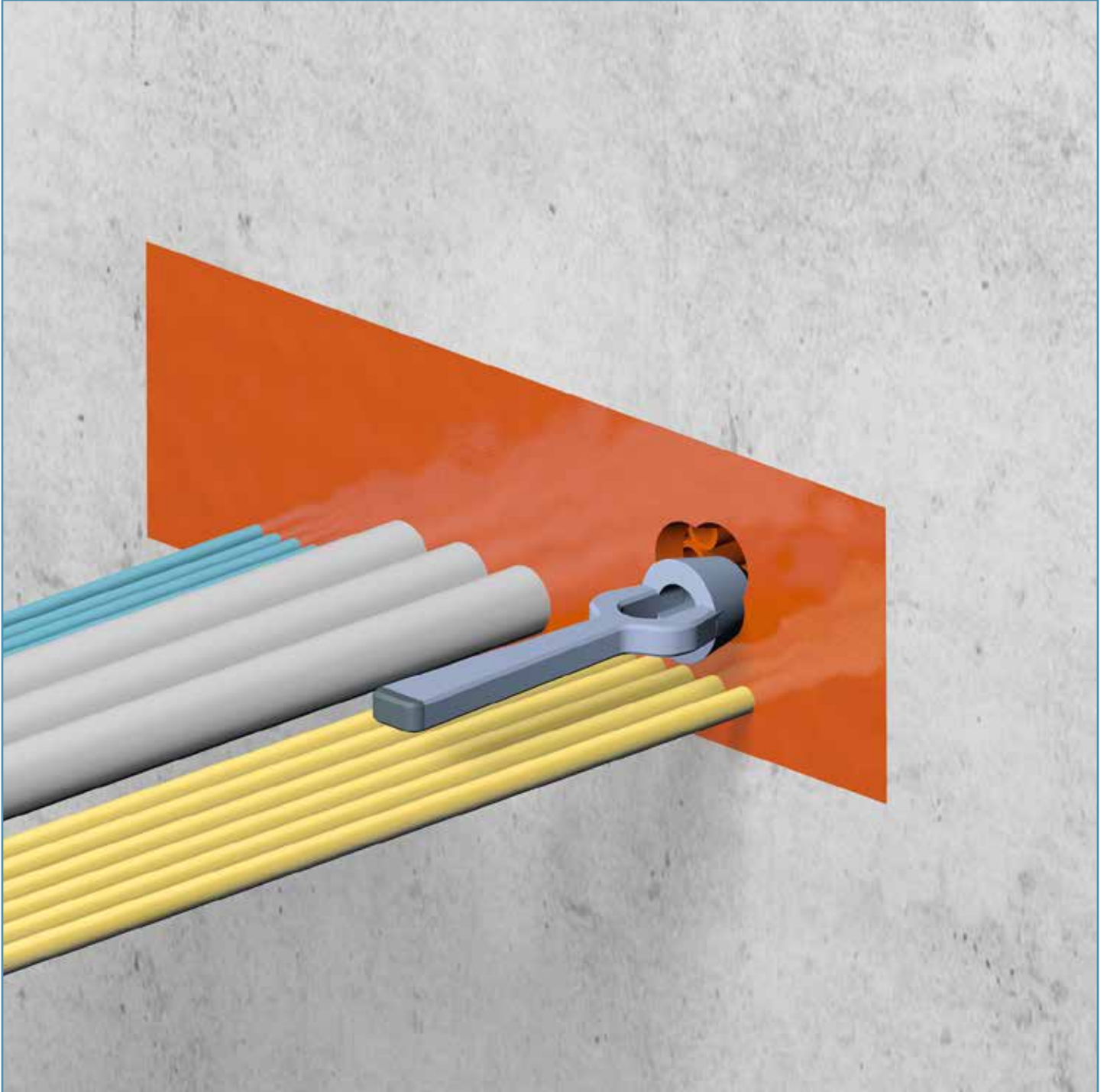

Adding extra cables through a finished NOFIRNO® multi-cable transit is an easy job. With the use of NOFIRNO® filler and NOFIRNO® cable insert sleeves as separators, no permanent deformation of the rubber parts will occur, and the cables are ducted individually. This means there is no need to disassemble the whole transit. Cut away the sealant layer at both sides of the penetration with a plastic knife or a hollow punch in a tapering shape, at a spot where there is sufficient spare space visible on the surface of the sealant layer.

## INSTALLATION INSTRUCTIONS FOR NOFIRNO® MULTI-CABLE TRANSIT SEALING SYSTEM (ADDING CABLE)

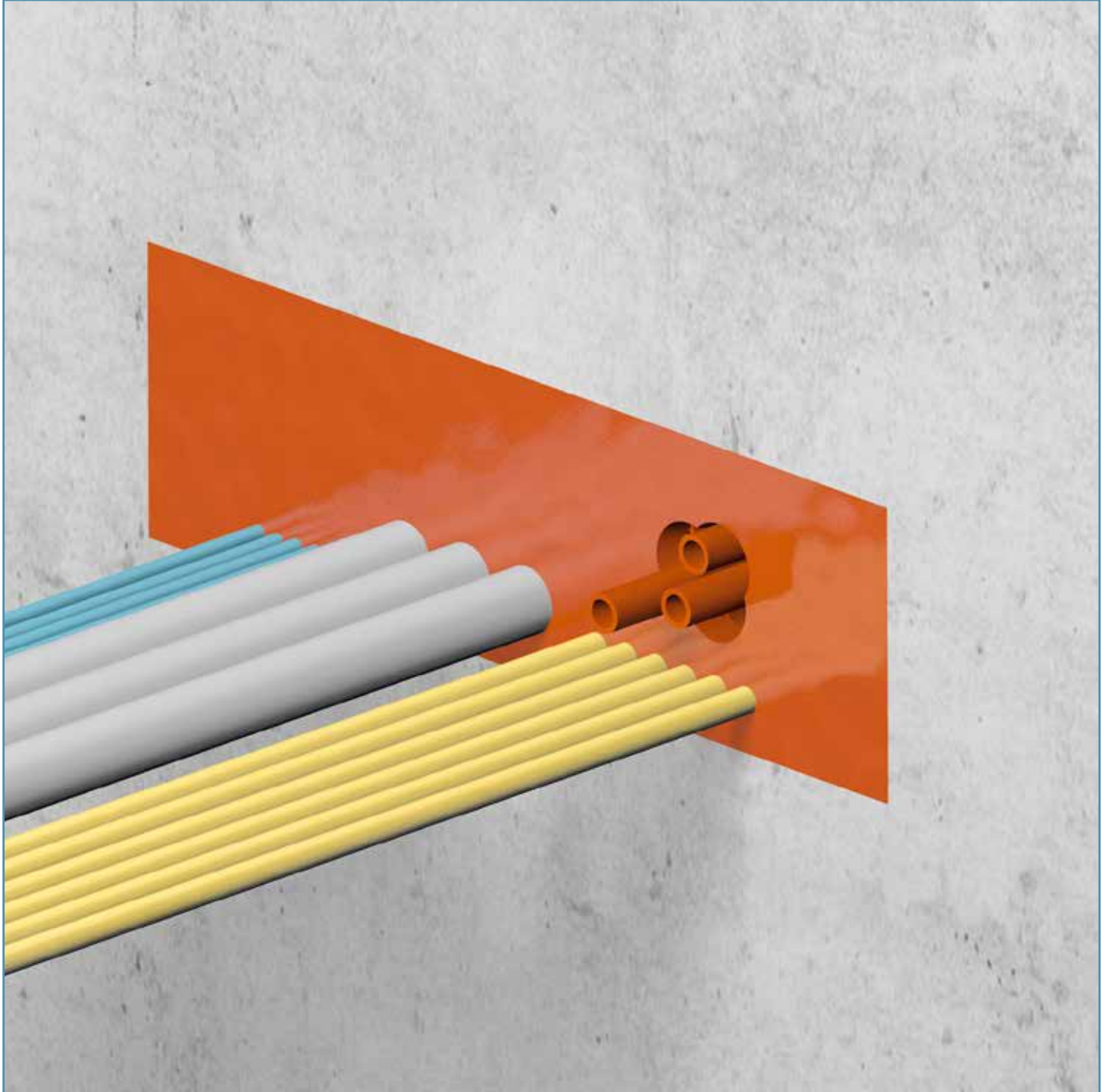

Remove one or more NOFIRNO® filler sleeves to create a fitting opening for the cable to be ducted.

## INSTALLATION INSTRUCTIONS FOR NOFIRNO® MULTI-CABLE TRANSIT SEALING SYSTEM (ADDING CABLE)

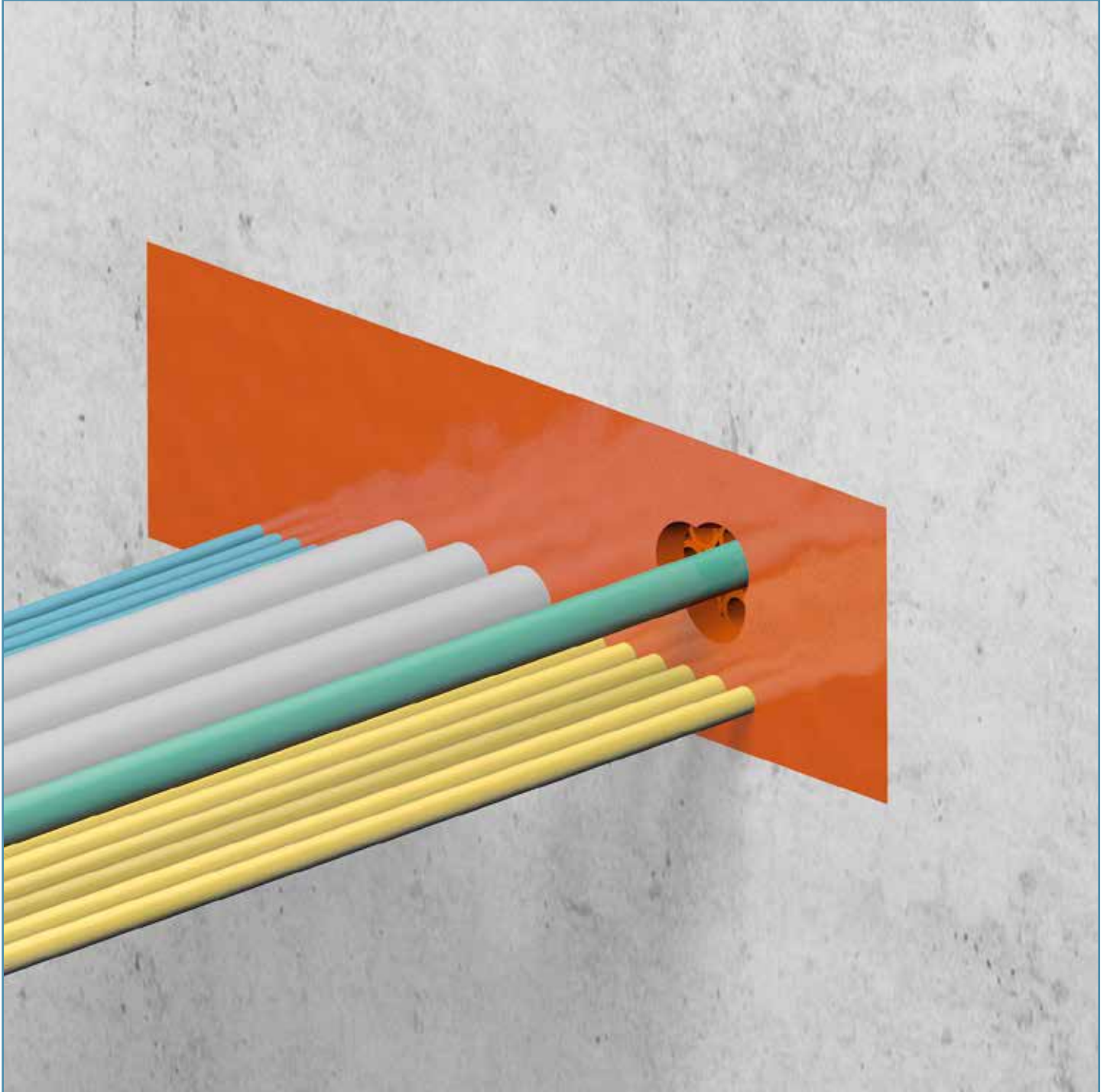

A cable is pulled through the free passage opening in the NOFIRNO® multi-cable transit. For adding cables, there is in fact no more disassembling needed than removing some filler sleeves. No extra costs for the extension of the cable set other than some new sealant to be applied.

## INSTALLATION INSTRUCTIONS FOR NOFIRNO® MULTI-CABLE TRANSIT SEALING SYSTEM (ADDING CABLE)

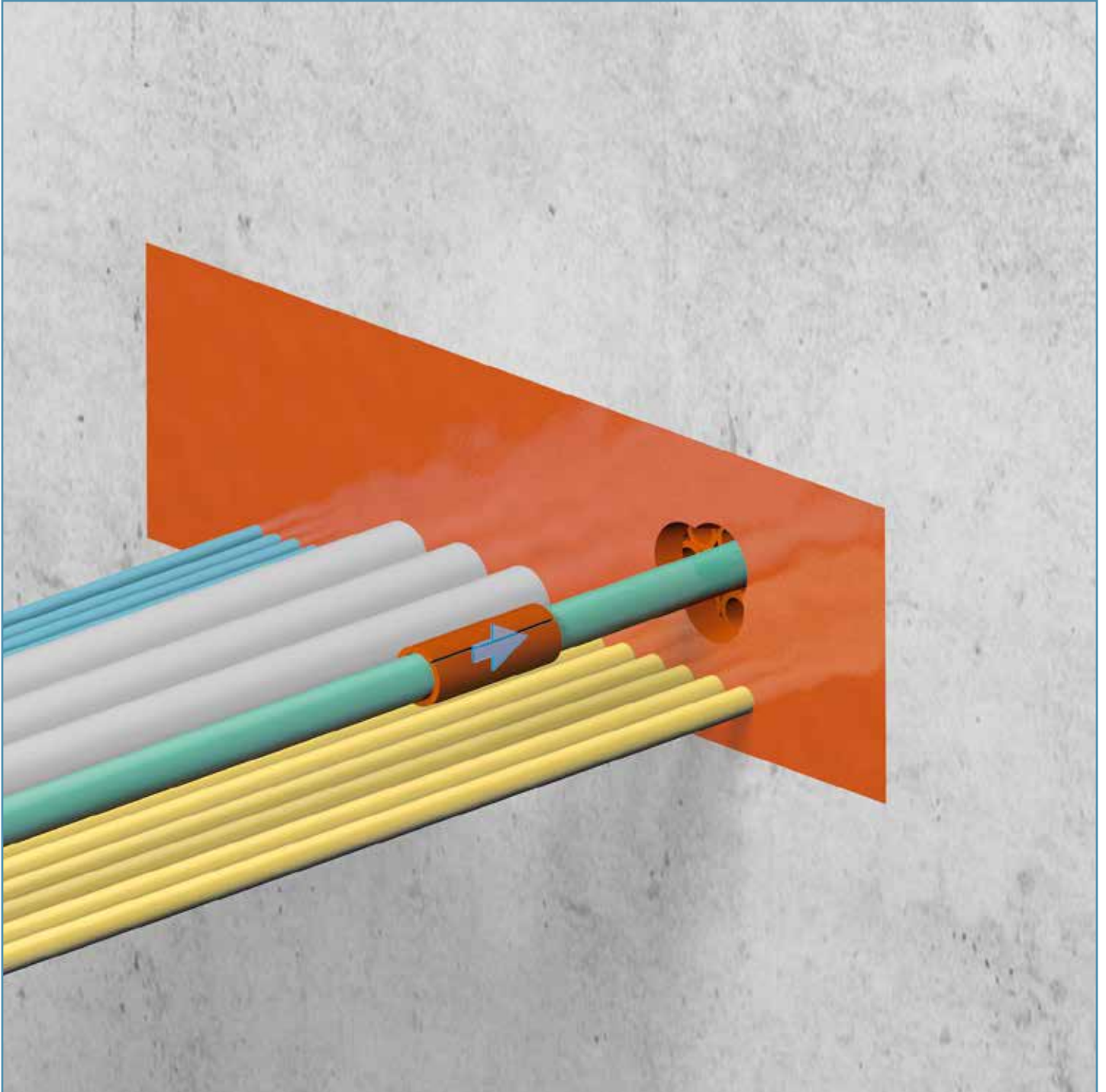

Place a NOFIRNO® cable insert sleeve around the newly ducted cable. Push the insert sleeve into the conduit so that it is even with the other sleeves. Replace, if necessary, some of the removed filler sleeves.

## INSTALLATION INSTRUCTIONS FOR NOFIRNO® MULTI-CABLE TRANSIT SEALING SYSTEM (ADDING CABLE)

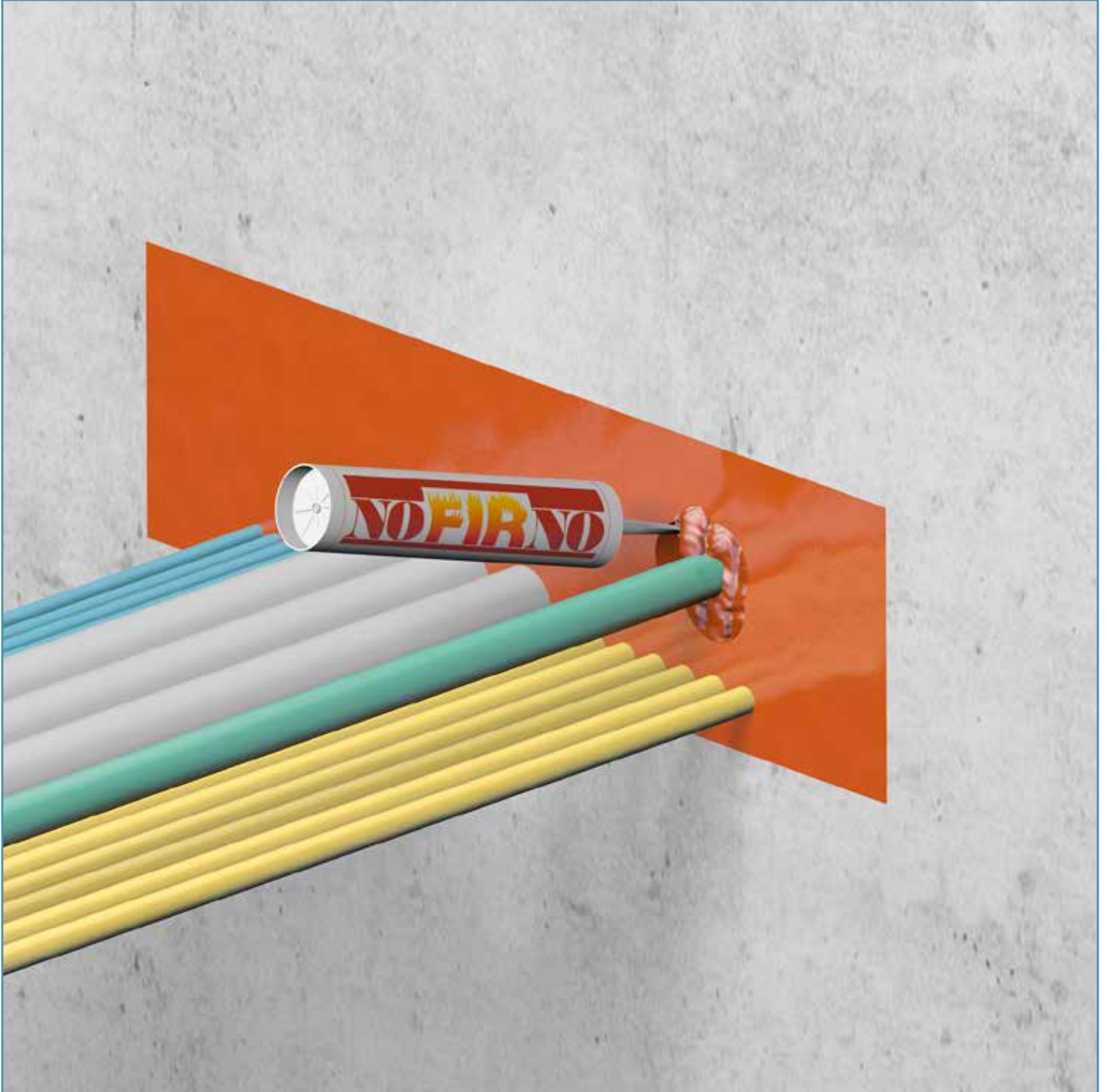

Clean and dry the newly ducted cable thoroughly and refill the opening in the sealant layer at both sides of the transit with NOFIRNO® sealant.

The fresh sealant adheres very well to the already cured sealant. Finish the new sealant layer in the same way as done for the initial sealant layer.

Please refer to the Safety Data Sheet for more information about the working environment.

## INSTALLATION INSTRUCTIONS FOR NOFIRNO® MULTI-CABLE TRANSIT SEALING SYSTEM (ADDING CABLE)



Note: time needed for curing of the sealant is dependent on air humidity in combination with the environmental temperature.

## INSTALLATION INSTRUCTIONS FOR NOFIRNO® BLIND TRANSIT SEALING SYSTEM

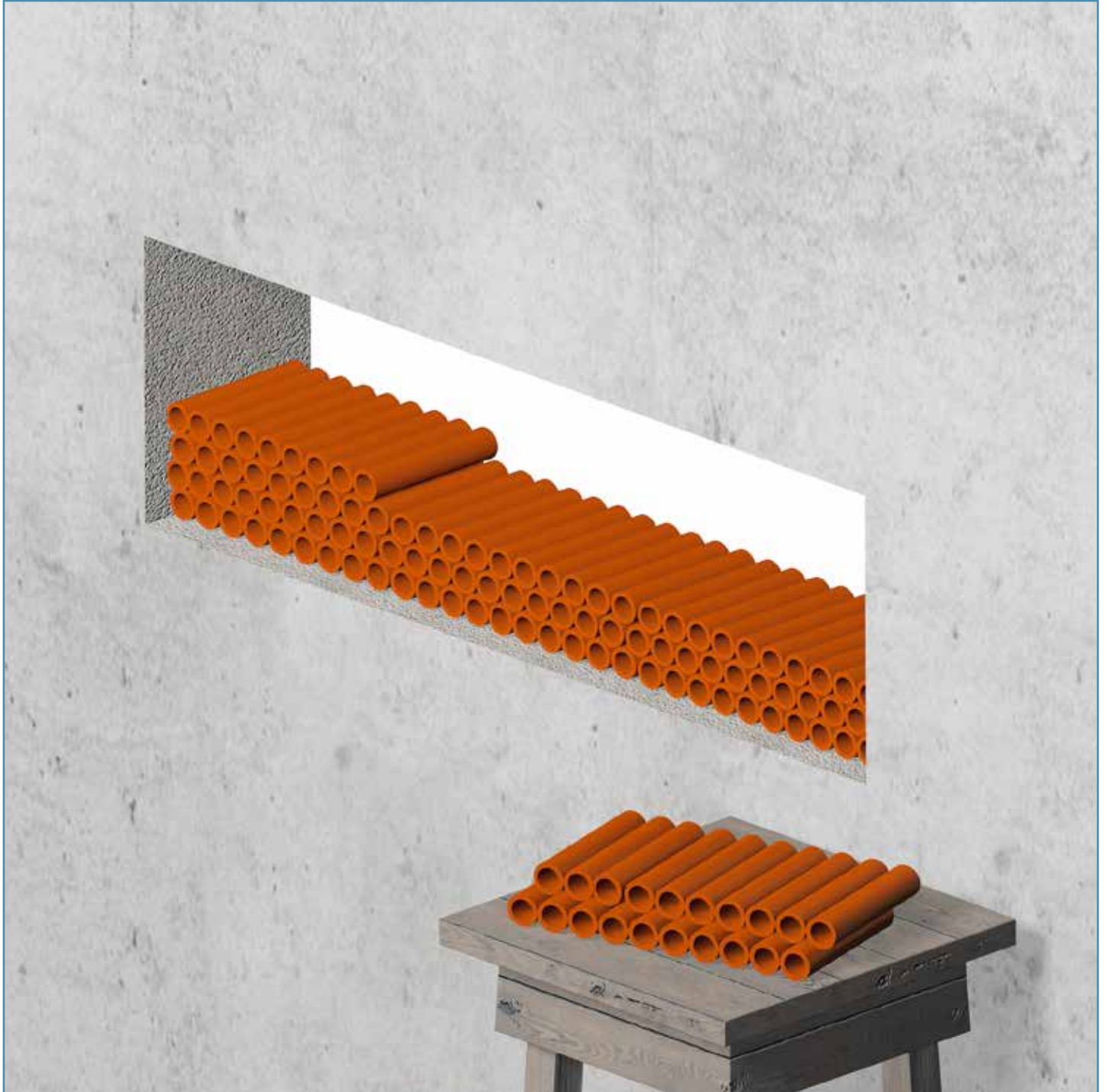

The space inside the conduit opening is filled with NOFIRNO® filler sleeves type 22/15. For ease of filling, the NOFIRNO® filler sleeves are supplied non-split. Multi-filler sleeves (set of 10) are preferred for filling larger spaces.

## INSTALLATION INSTRUCTIONS FOR NOFIRNO® BLIND TRANSIT SEALING SYSTEM



Before applying the NOFIRNO® sealant, it is advisable to perform a final check on the packing of the filler sleeves. A tight fit of the whole set of sleeves is not only vital for the mechanical stability of the sealing system, but also for the fire stopping properties. A final check should therefore be a part of quality control.

Please refer to the Safety Data Sheet for more information about the working environment.

## INSTALLATION INSTRUCTIONS FOR NOFIRNO® BLIND TRANSIT SEALING SYSTEM



The finished blind penetration.

## INSTALLATION INSTRUCTIONS FOR NOFIRNO® BLIND TRANSIT SEALING SYSTEM

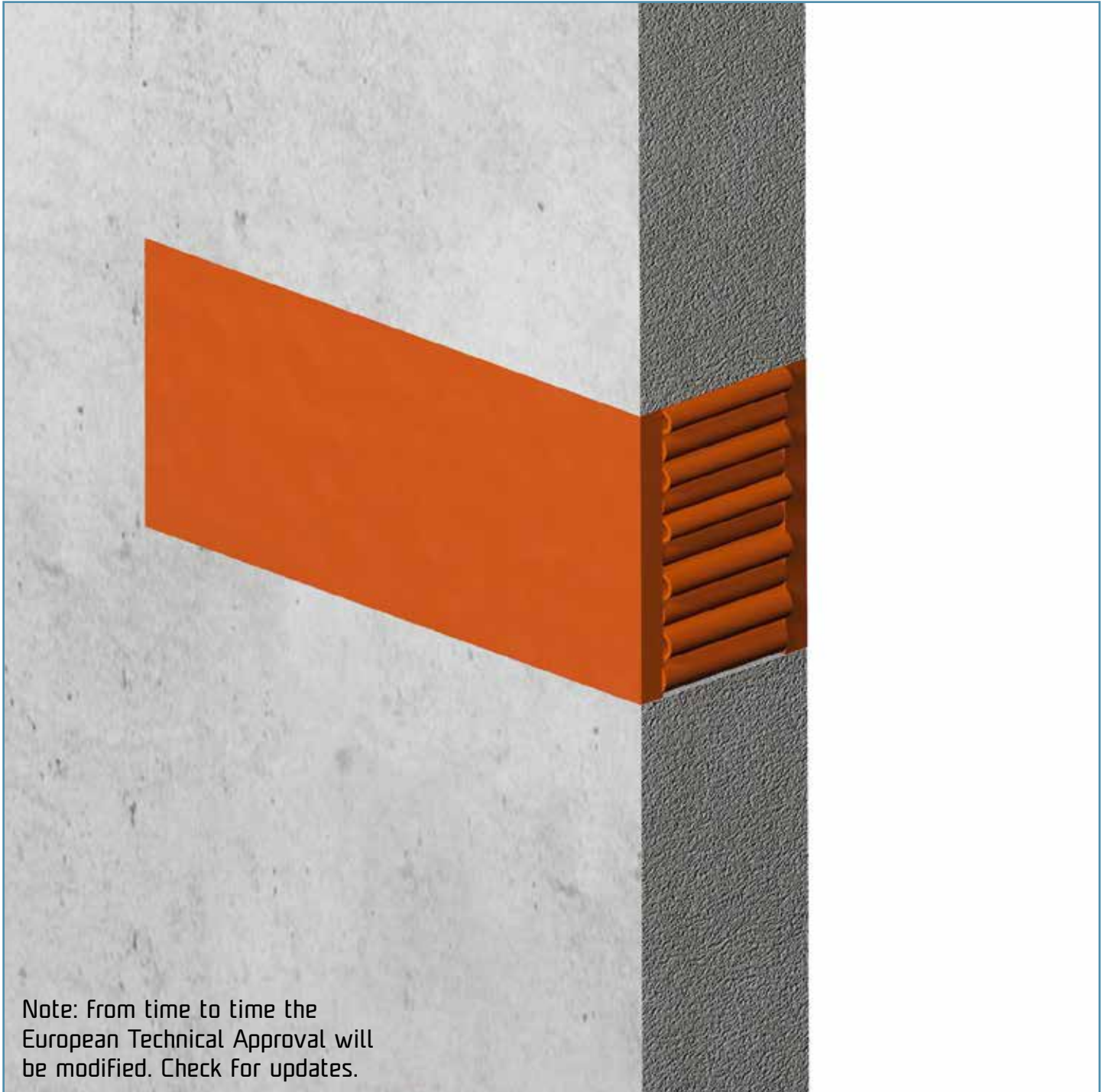

Note: From time to time the European Technical Approval will be modified. Check for updates.

The maximum size of the NOFIRNO® blind penetrations is 600x600 mm or an equivalent of 3600 cm<sup>2</sup>. Minimum wall thickness is 100 mm. Tested successfully according to EN 1366-3:2009 for 4 hours without exceeding the maximum allowable temperature rise of 180 °C. Classification EI240/E240. European Technical Approval 13-053 release February 27, 2017.

## INSTALLATION INSTRUCTIONS FOR NOFIRNO® BLIND TRANSIT SEALING SYSTEM IN FLOORS

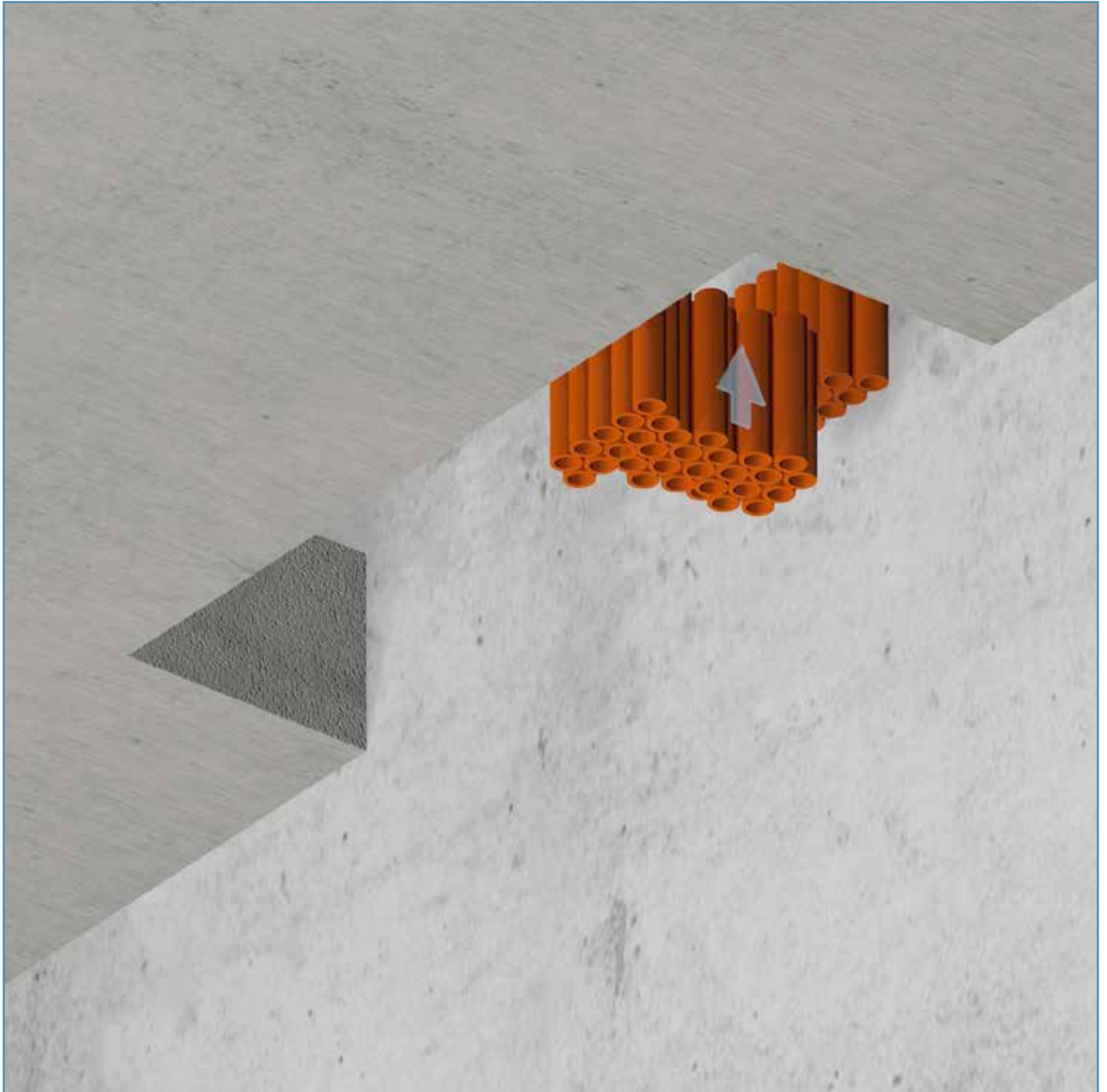

The multi-filler sleeves are very useful, especially for sealing floor penetrations. By making use of the NOFIRNO® multi-filler sleeves, sets and bundles can be made to ensure tight fitting inside the conduit opening. Inserting fitting sets or bundles of multi-sleeves will ensure that sleeves won't fall out of the conduit opening.

## INSTALLATION INSTRUCTIONS FOR NOFIRNO® BLIND TRANSIT SEALING SYSTEM IN FLOORS



The NOFIRNO® sealant can be applied overhead for floor transits without dripping or sagging. After application of the sealant, the NOFIRNO® sealant is pressed tightly with a cloth sprayed with water. This prevents the sealant from sticking to the cloth.

Use protective gloves when working with NOFIRNO® sealant. Please refer to the Safety Data Sheet for more information

## INSTALLATION INSTRUCTIONS FOR NOFIRNO® BLIND TRANSIT SEALING SYSTEM IN FLOORS

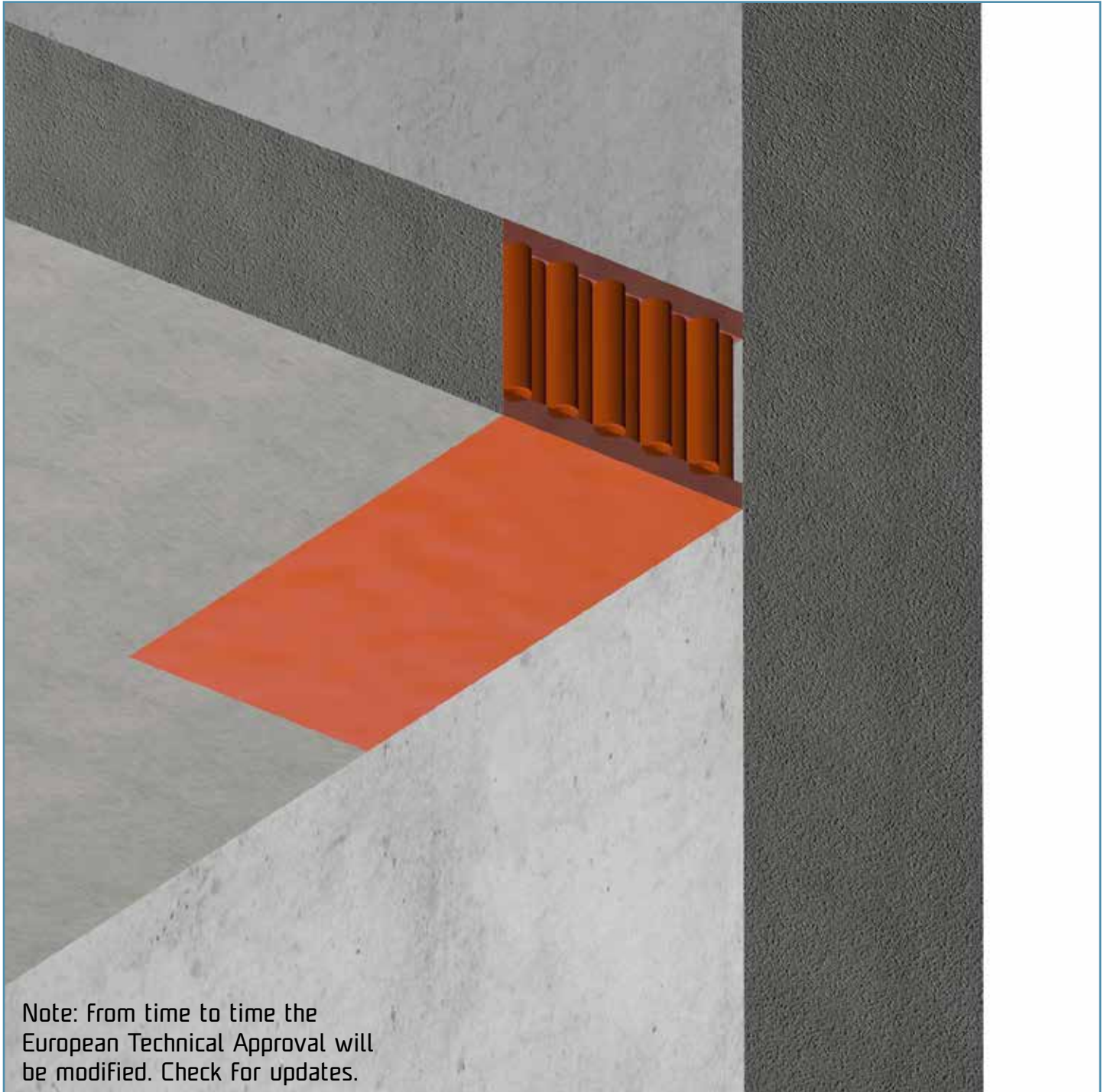

Note: From time to time the European Technical Approval will be modified. Check for updates.

The finished penetration at the underside of the floor.

The NOFIRNO® system for blind penetrations with a dimension of 1200x300 mm or equivalent of 3600 cm<sup>2</sup> mm has been successfully tested according to EN 1366-3:2009 for two hours in floors with a thickness of 150 mm and obtained a fire classification of EI120/E120.

European Technical Approval 13-053 release February 27, 2017.

# STATE-OF-THE ART MULTI-CABLE TRANSIT SEALING SYSTEMS

The logo for RISE, featuring the word "RISE" in a stylized, bold, red font with a white outline and a slight 3D effect. The letters are slightly slanted.The logo for RISE, featuring the word "RISE" in a stylized, bold, red font with a white outline and a slight 3D effect. The letters are slightly slanted.The logo for CONDUCTION, featuring the word "CONDUCTION" in a red, outlined font with a double-line border. The letters are slightly slanted.The logo for NOFIRNO, featuring the word "NOFIRNO" in a bold, orange font with a white outline. The letters are slightly slanted.The logo for CONTROFIL, featuring the word "CONTROFIL" in a bold, blue font with a white outline. Below it, the words "MULTI-CABLE TRANSITS" are written in a smaller, white font on a blue background.The logo for CET-A-SIL, featuring the words "CET-A-SIL" in a bold, blue font with a white outline. The letters are slightly slanted.

## RISE®

- For fire, gas, smoke and watertight sealing of multi-cable penetrations.
- Compact system. No precise fitting parts.
- No metal parts, no corrosion.
- Most cost-effective way of installation.
- No pre-engineering or special conduit frames.
- No restrictions on cable types and sizes, no insulation in front of the penetration needed.
- Adding or removing cables an easy matter.
- RISE® EXTEND-A-FRAME for upgrading block systems - doubles the usable space!
- RISE® CONDUCTION® for EMC penetrations - high attenuation values - no galvanic corrosion - no aging.
- **Proven - for new and upgraded installations.**
- The system of choice in shipyards worldwide for more than 25 years!

## NOFIRNO®

- System technology based on RISE®.
- Even easier installation.
- Even higher pressure ratings.
- Jet Fire tested for harshest applications.
- Bundled cable sets approved
- **Breakthrough - A-class with 15 mm both sides.**
- The system of choice for highest fire ratings and harshest environment!

## CONTROFIL®

- Newest technology for cable ducting and sealing.
- Newest rubber technology - CRUSHNOF® rubber.
- Shorter conduit depths - flexible composition.
- Prevents overfilling of cable transits.
- Fire tight - watertight.
- **Breakthrough - controlled filling of transits.**
- The system of choice for neat cable routing in installations.

## CET-A-SIL®

- Multi-gland system for electrical cabinets.
- Modular system - sealing plugs and modules.
- Suitable for IP 68 rated equipment.
- Watertight up to 4 meter water column.
- No compression on cable sheathings.
- No metal parts - no corrosion - no O-rings.
- **Breakthrough - no disassembling to add cables.**
- The alternative system for cable glands.

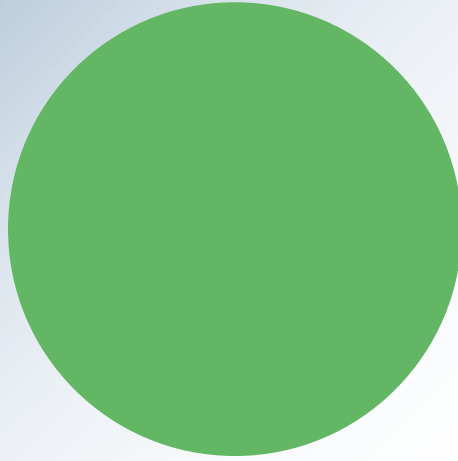

***WE CARE***

**BEELE ENGINEERING:  
A COMPANY DEDICATED  
TO SAFETY  
FOR OVER 45 YEARS**



BEELE Engineering bv  
Beunkdijk 11 - 7122 NZ AALTEN - THE NETHERLANDS  
Tel. +31 543 461629 - Fax +31 543 461786 - E-mail: [info@beele.com](mailto:info@beele.com)  
Websites: <https://www.beele.com>, [sealingvalley.com](https://sealingvalley.com) and [fissiccoating.com](https://fissiccoating.com)