

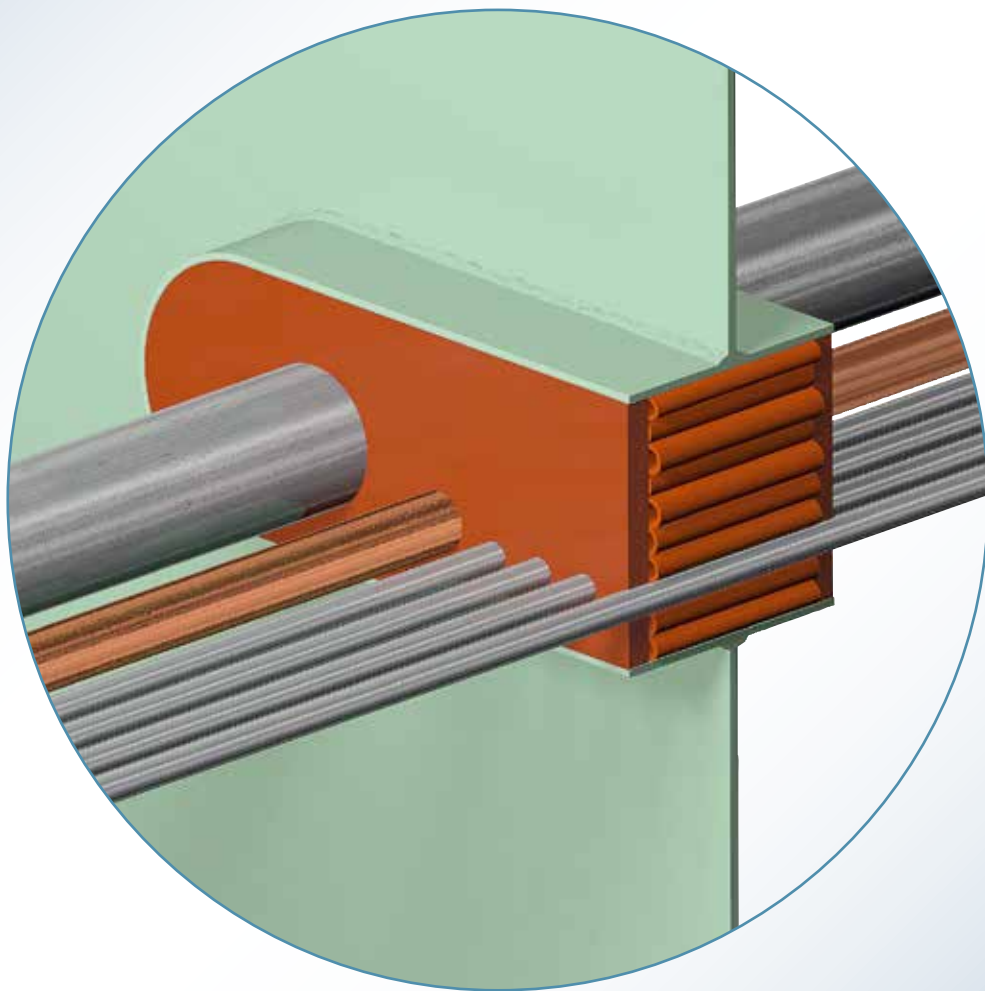

# INSTALLATION INSTRUCTIONS NOFIRNO<sup>®</sup> SEALING SYSTEM (NOFIRNO<sup>®</sup> SLEEVES/SEALANT) FOR (MULTI-) PIPE TRANSITS



**NO FIRNO<sup>®</sup>**



# SEALING VALLEY

KNOWLEDGE TRANSFER, EDUCATION AND TRAINING

Beele campus 45.000 m<sup>2</sup>  
Ready 2020/2021



- A: Reception, Education Center, Workshops, Video Conferences  
 B: Demonstration, Training and Installation  
 C: R&D center, Testing Facilities  
 D: Pilot plant for new developments  
 E: Production Plant phase 1 and 2  
 F: Park with amphitheater and food forest 15.000 m<sup>2</sup>

**Copyright** : BEELE Engineering BV, Aalten, the Netherlands.  
 Proprietary rights on all drawings and technical data released in this brochure. © 1997-2022

**Edition** : January 2022

**Note** : No part of this publication may be reproduced without explicit written approval of BEELE Engineering BV.

**Research & Development** : BEELE Engineering BV, Aalten, the Netherlands.

**Note** : The manufacturer reserves the right to make dimensional and design modifications without prior notification.

© : ACTIFOAM, AQUASTOP, BEEBLOCK, BEELE, BEELE WE CARE, BEESEAL, CET-A-SIL, CONDUCTION, CONTROLFIL, CRUSHER, CSD, DYNATITE, FIRAQUA, FIRSTO, FISSIC, FIWA, FYLLOFYS, FYLLOFOAM, GLANDMOD, LEAXEAL, NOFIRNO, RISE, SEALING VALLEY, S, SLIPSIL, Ranges SLIPSIL plugs are registered trade marks of BEELE Engineering.

**brochure code** : installation NOFIRNO pipe

## INSTALLATION INSTRUCTIONS FOR NOFIRNO® (MULTI-) PIPE TRANSIT SEALING SYSTEM



The NOFIRNO® (multi-) pipe transit sealing system is composed of NOFIRNO® (multi-) filler sleeves type 22/15 and NOFIRNO® sealant. To fill smaller openings in the filler set NOFIRNO® (multi-) filler sleeves type 10/4, 15/8, 18/12 and 20/12 can be used. The use of NOFIRNO® multi-filler sleeves type 22/15 contributes to ease of installation, due to the fact that there is no ratio anymore to be regarded as was the case with the combination type 18/12 and 27/19. Furthermore, the use of filler sleeves 22/15 eliminates making mistakes in the ratio 1:2 to be applied for the combination 18/12 and 27/19 filler sleeves.

## INSTALLATION INSTRUCTIONS FOR NOFIRNO® (MULTI-) PIPE TRANSIT SEALING SYSTEM

### PRODUCT INFORMATION SEALANT

|                         |   |
|-------------------------|---|
| 01) colour              | red brown   |
| 02) specific gravity    | 1.40 ± 0.03 g/cm <sup>3</sup>   |
| 03) curing of top layer | 0.5 - 1 hour depending on temperature and air humidity  |
| 04) service temperature | -50 °C up to +180 °C  |
| 05) tensile strength    | 1.5 MPa   |
| 06) elongation at break | 200%  |
| 07) hardness            | 45 Shore A  |
| 08) elastic deformation | approx. 50%   |
| 09) resistance          | UV, Ozone, arctic conditions  |
| 10) ageing              | more than 20 years  |
| 11) supplied in         | 310 ml cartridges   |
| 12) storage             | to be stored cool and dry<br>min/max temperature = +5/+30° C  |
| 13) storage life        | guaranteed 6 months; when applied later than 6 months<br>after date of manufacturing, curing and adhesive<br>properties have to be checked before application |

article number 50.0107



*NOFIRNO® is absolutely HALOGEN FREE with zero VOC (volatiles organic compounds) according to TÜV report 89206405-01. Furthermore NOFIRNO® has a low smoke index and a high oxygen index (ISO 4589-2: 1996), and low flame spread characteristics according to IMO Resolution A.653(16). NOFIRNO® is a paste-like compound which is simple to use. NOFIRNO® has a balanced viscosity and can be applied overhead.*

blue



article number 50.0108

black



article number 50.0109

white



article number 50.0110

grey



article number 50.0111

**INSTALLATION INSTRUCTIONS FOR NOFIRNO®  
(MULTI-) PIPE TRANSIT SEALING SYSTEM**

**NOFIRNO® MULTI-FILLER SLEEVES**



**NOFIRNO® Filler sleeve 10/4 multi 12**

- art. no. 50.0301 for 60 mm length
- art. no. 50.0361 for 80 mm length
- art. no. 50.0311 for 110 mm length
- art. no. 50.0351 for 130 mm length
- art. no. 50.0321 for 140 mm length
- art. no. 50.0331 for 160 mm length
- art. no. 50.0341 for 210 mm length

to be used for smaller conduit openings



**NOFIRNO® Filler sleeve 15/8 multi 8**

- art. no. 50.0302 for 60 mm length
- art. no. 50.0362 for 80 mm length
- art. no. 50.0312 for 110 mm length
- art. no. 50.0352 for 130 mm length
- art. no. 50.0322 for 140 mm length
- art. no. 50.0332 for 160 mm length
- art. no. 50.0342 for 210 mm length

**NOFIRNO® Filler sleeve 20/12 multi 6**

- art. no. 50.0303 for 60 mm length
- art. no. 50.0363 for 80 mm length
- art. no. 50.0313 for 110 mm length
- art. no. 50.0353 for 130 mm length
- art. no. 50.0323 for 140 mm length
- art. no. 50.0333 for 160 mm length
- art. no. 50.0343 for 210 mm length

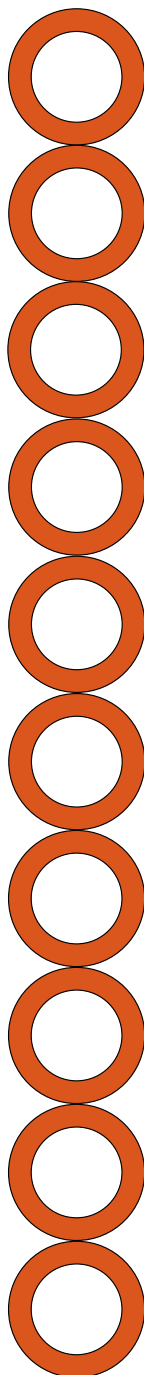

**NOFIRNO® Filler sleeve 18/12 multi 10**

- art. no. 80.5050 for 60 mm length
- art. no. 80.5056 for 80 mm length
- art. no. 80.5051 for 110 mm length
- art. no. 80.5055 for 130 mm length
- art. no. 80.5052 for 140 mm length
- art. no. 80.5053 for 160 mm length
- art. no. 80.5054 for 210 mm length

to be used for larger conduit openings

Filler sleeves are supplied non-split

Operating temperatures:  
-50 °C up to +180 °C

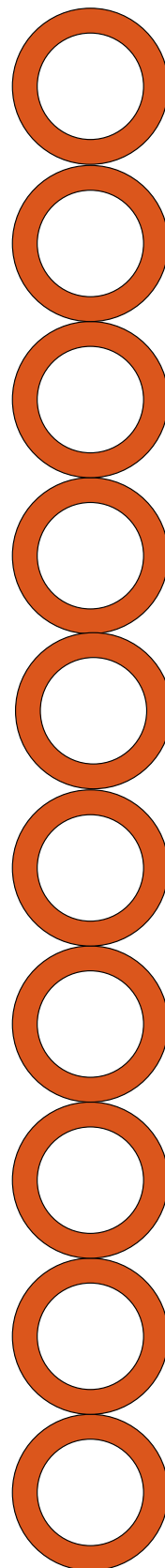

**NOFIRNO® Filler sleeve 22/15 multi 10**

- art. no. 80.5070 for 60 mm length
- art. no. 80.5076 for 80 mm length
- art. no. 80.5071 for 110 mm length
- art. no. 80.5075 for 130 mm length
- art. no. 80.5072 for 140 mm length
- art. no. 80.5073 for 160 mm length
- art. no. 80.5074 for 210 mm length

to be used for larger conduit openings

**INSTALLATION INSTRUCTIONS FOR NOFIRNO®  
(MULTI-) PIPE TRANSIT SEALING SYSTEM**



The tools needed for the installation are a steel brush, a tie-wrap cutter, a cutter for the nozzles of the sealant cartridges, flat nose pliers to adjust the set of fillers, a filler set adjuster, cloths for cleaning and compression of the sealant layer, a pipe cleaner, a bucket with water and a professional sealant dispenser.

## **INSTALLATION INSTRUCTIONS FOR NOFIRNO® SINGLE PIPE TRANSIT SEALING SYSTEM**

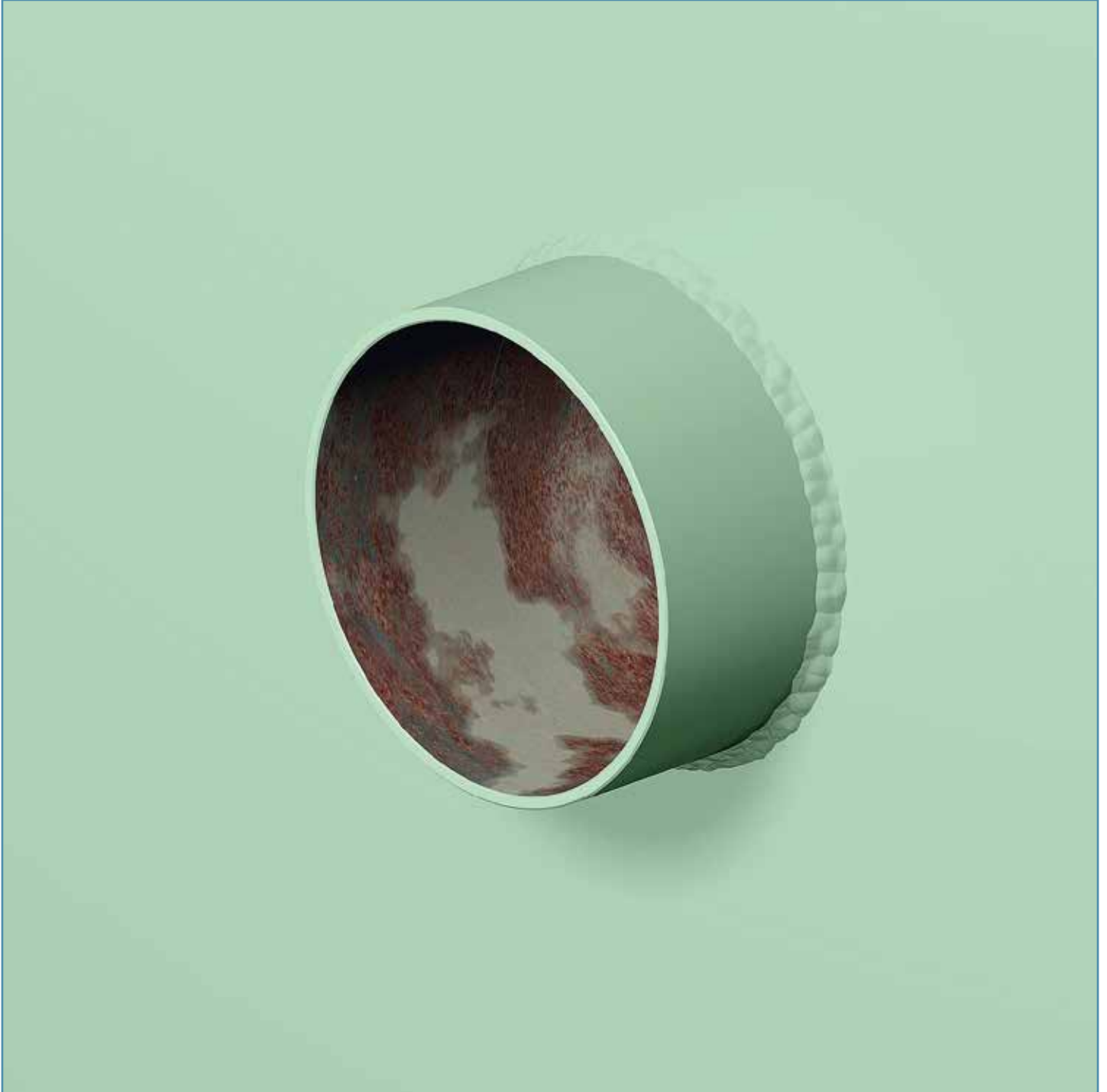

The conduit sleeves might be welded into the partition long before pipe installation will start. For this reason, the condition of the inside of the sleeve has to be checked when starting ducting pipes. Before insertion of the NOFIRNO® filler sleeves, the inside of the conduit sleeve has to be cleaned, and any dirt, oil, grease and other residues or corrosion should be removed from the inside of the conduit sleeve.

**INSTALLATION INSTRUCTIONS FOR NOFIRNO®  
SINGLE PIPE TRANSIT SEALING SYSTEM**

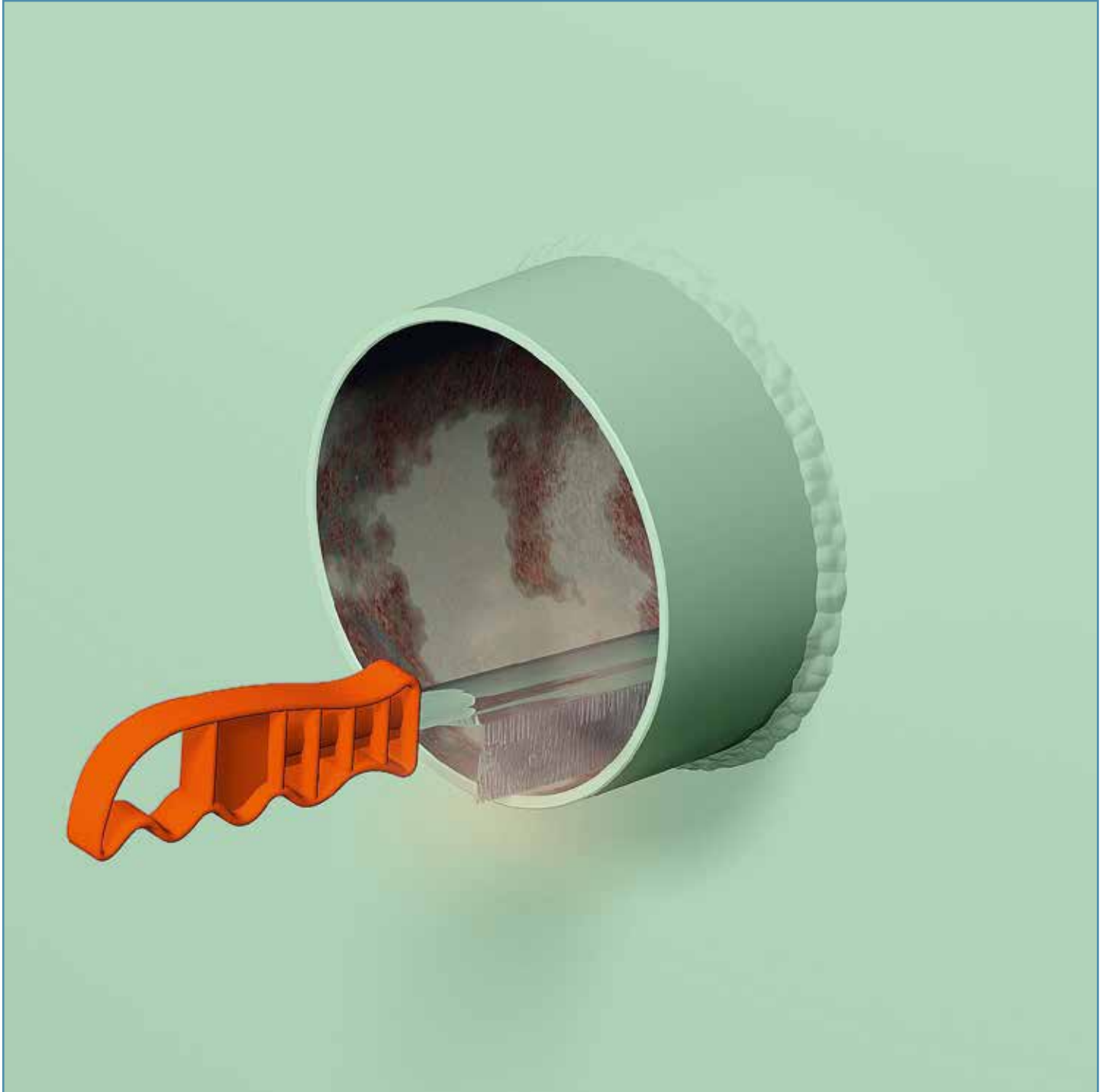

With a steel brush or by blasting, the corroded inner surface of the conduit sleeve should be treated to remove these corroded spots. The excellent adhesive properties of the sealing system will be diminished by corroded surfaces.

**INSTALLATION INSTRUCTIONS FOR NOFIRNO®  
SINGLE PIPE TRANSIT SEALING SYSTEM**

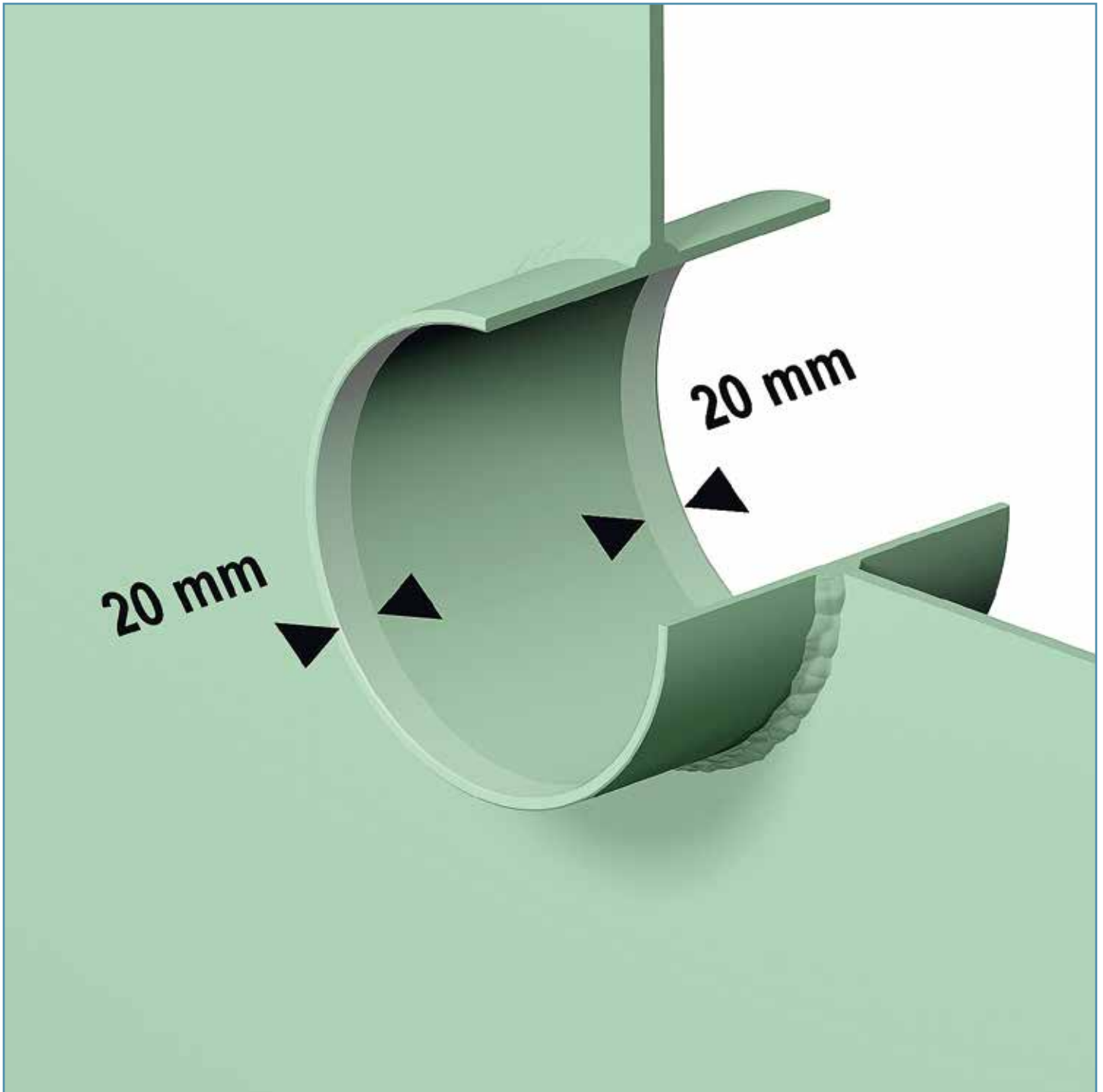

The NOFIRNO® sealing system is composed of filler sleeves, and layers of sealant. The filler sleeves are the backing on which the sealant is going to be applied. A 20 mm thick layer of sealant is applied at both sides of the penetration. Before welding the conduit sleeve into the partition, check if the conduit sleeve is deep enough to be in line with the certification of the sealing system. The NOFIRNO® filler sleeves are 40 mm shorter in length than the depth of the conduit sleeve.

## INSTALLATION INSTRUCTIONS FOR NOFIRNO® SINGLE PIPE TRANSIT SEALING SYSTEM

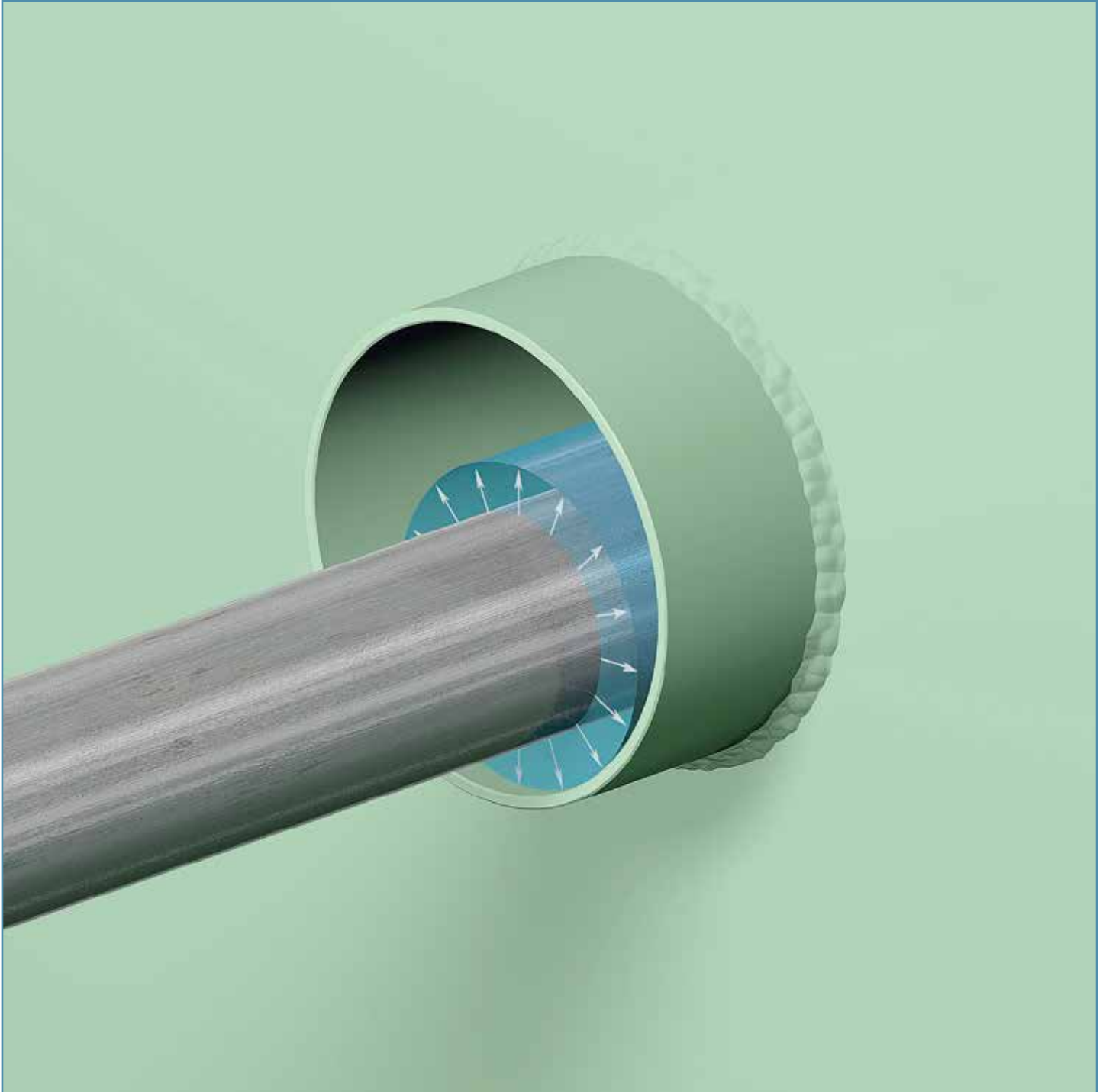

The metallic or GRE pipe can be passed through the conduit sleeve in an off centre position, provided there is enough space between the conduit sleeve and the ducted pipe. Make sure that the minimum space between the pipe and the wall of the conduit sleeve is in accordance with the minimum allowed distance as certified.

## INSTALLATION INSTRUCTIONS FOR NOFIRNO® SINGLE PIPE TRANSIT SEALING SYSTEM

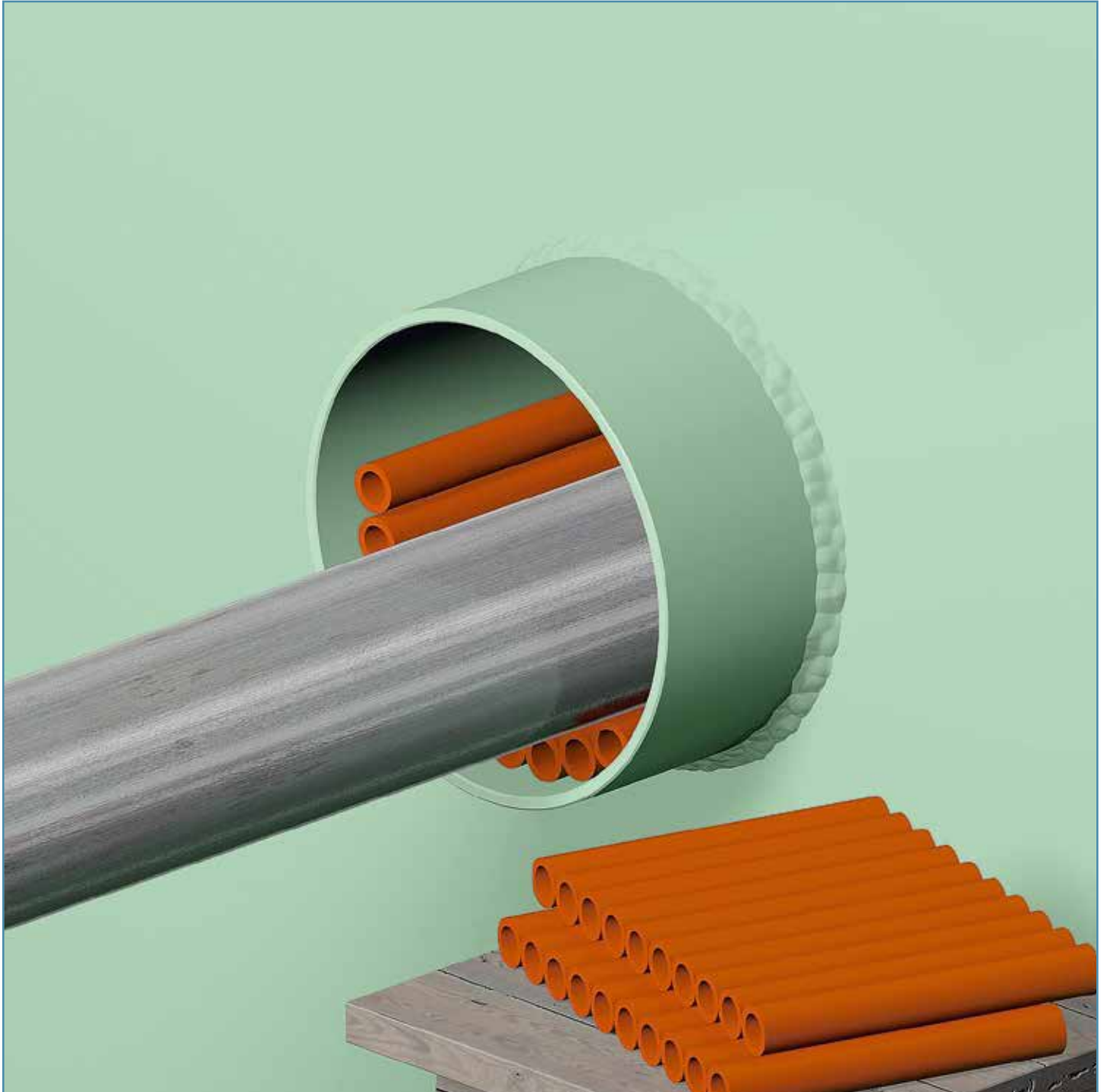

The open space between the conduit sleeve and the ducted pipe is filled with NOFIRNO® multi-filler sleeves type 22/15. For ease of filling, the NOFIRNO® filler sleeves are supplied non-split. The insertion does not have to be precise in this regard. Adjustment of the set of sleeves to the 20 mm recess can be carried out just before applying the sealant.

## INSTALLATION INSTRUCTIONS FOR NOFIRNO® SINGLE PIPE TRANSIT SEALING SYSTEM

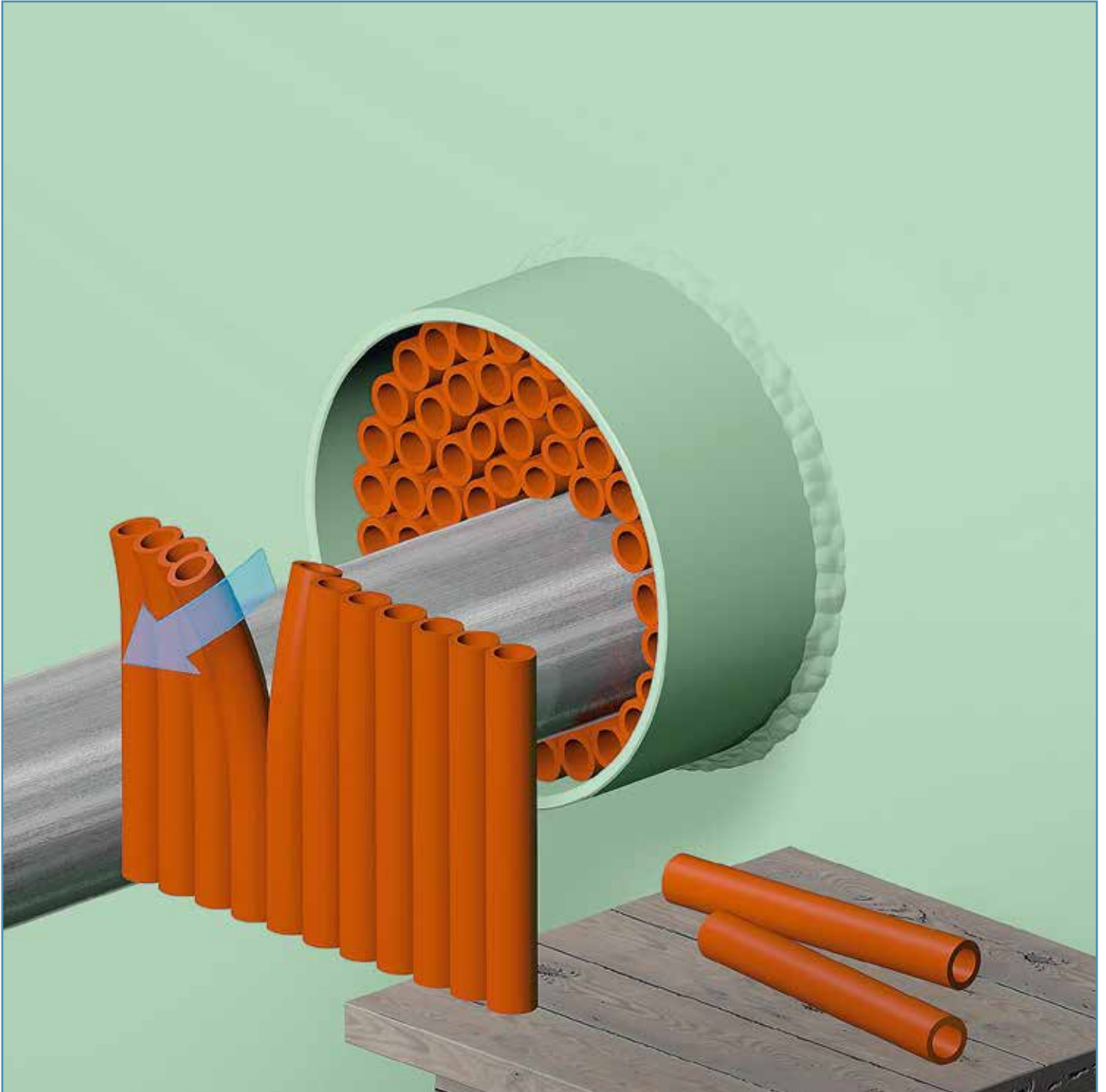

The smaller openings are now filled with parts of the sets of multi-filler sleeves. To tear off sleeves from the multi-set, the procedure is to do this backwards/forwards and not sideways. This is because of the strength of the intermediate rubber parts.

**INSTALLATION INSTRUCTIONS FOR NOFIRNO®  
SINGLE PIPE TRANSIT SEALING SYSTEM**

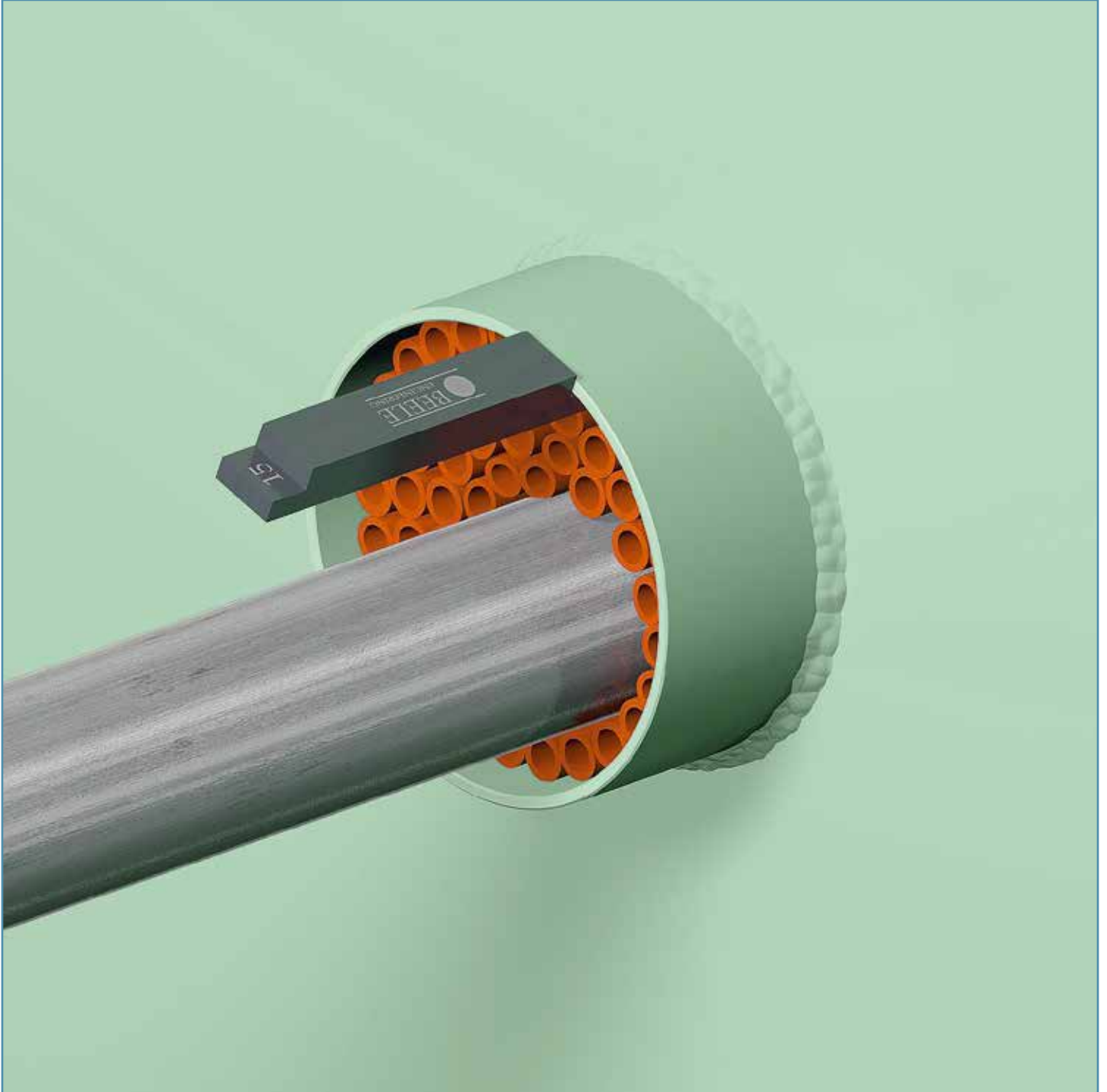

With a piece of wood marked with the required 20 mm depth, or with the aluminum adjuster developed by BEELE Engineering. Use a plastic hammer to adjust the set of filler sleeves with the NOFIRNO® adjuster.

**INSTALLATION INSTRUCTIONS FOR NOFIRNO®  
SINGLE PIPE TRANSIT SEALING SYSTEM**

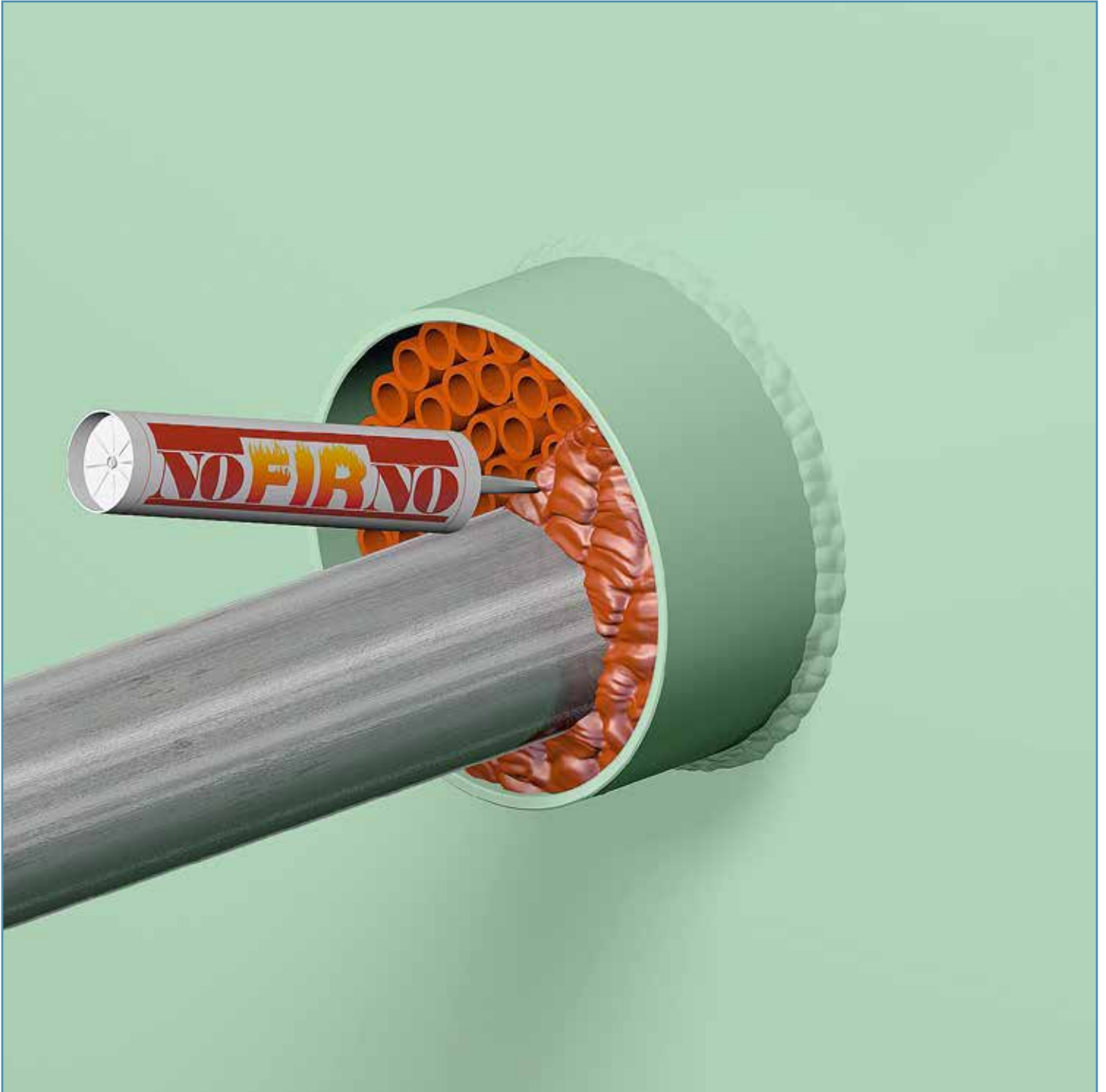

A 20 mm thick layer of NOFIRNO® sealant is applied at each side of the conduit. Clean and dry the conduit opening, as well as the pipe thoroughly, and remove any dirt, rust or oil residues before applying the sealant.

## INSTALLATION INSTRUCTIONS FOR NOFIRNO® SINGLE PIPE TRANSIT SEALING SYSTEM

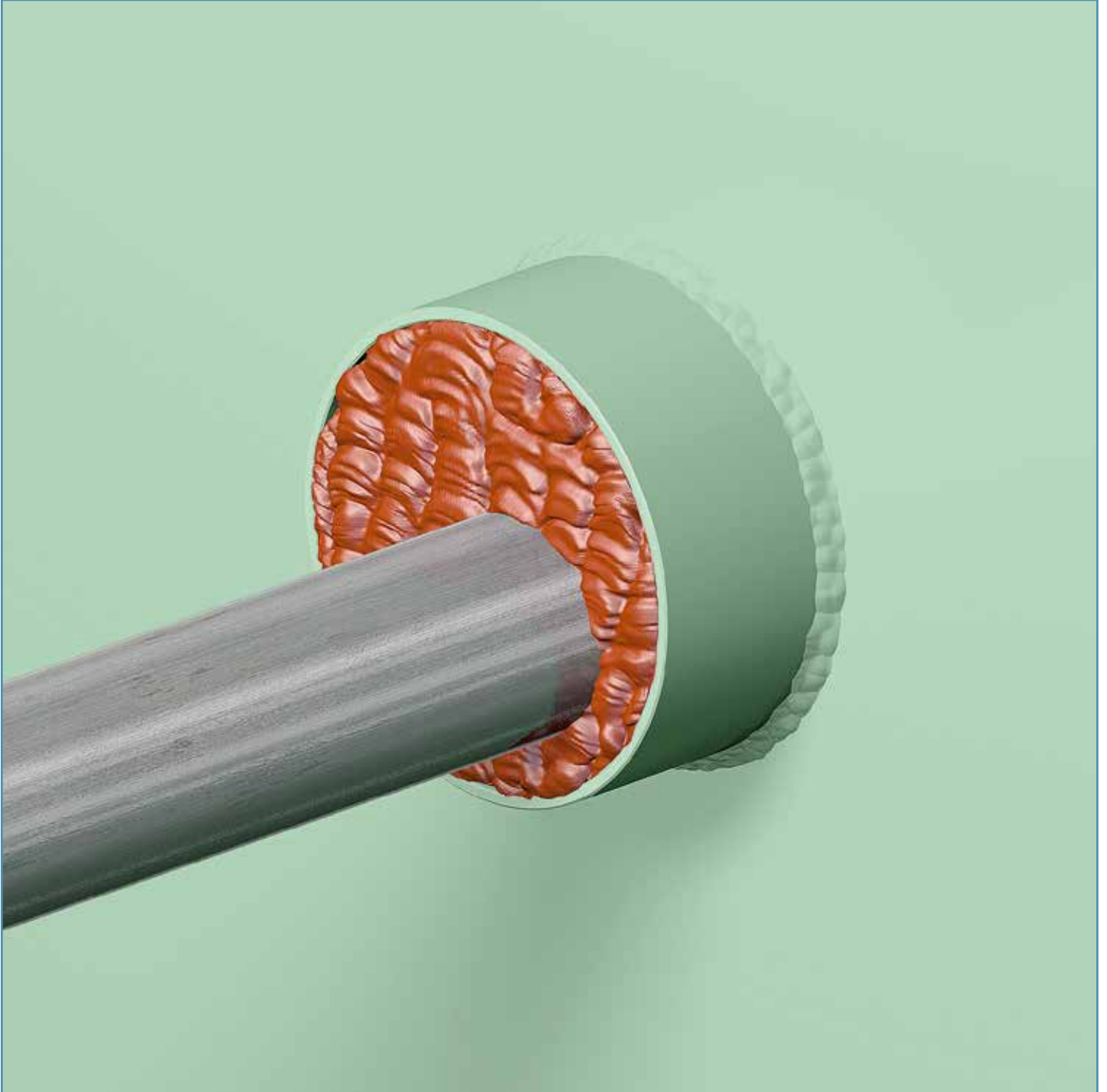

The pipe transit should be overfilled with NOFIRNO® sealant, because some sealant will be pushed into the empty spaces between and into the hollow NOFIRNO® (multi) filler sleeves during further finishing. This will contribute also to obtain higher tightness ratings.

Skin formation of the sealant takes place after ca. 10-15 minutes. In case of larger transits, do not apply more sealant than can be finished within this time-frame.

**INSTALLATION INSTRUCTIONS FOR NOFIRNO®  
SINGLE PIPE TRANSIT SEALING SYSTEM**



To smooth the surface of the NOFIRNO® sealant layer, a cloth is sprayed with water. This prevents the sealant from sticking to the cloth.

Please refer to the Safety Data Sheet for more information about the working environment.

**INSTALLATION INSTRUCTIONS FOR NOFIRNO®  
SINGLE PIPE TRANSIT SEALING SYSTEM**

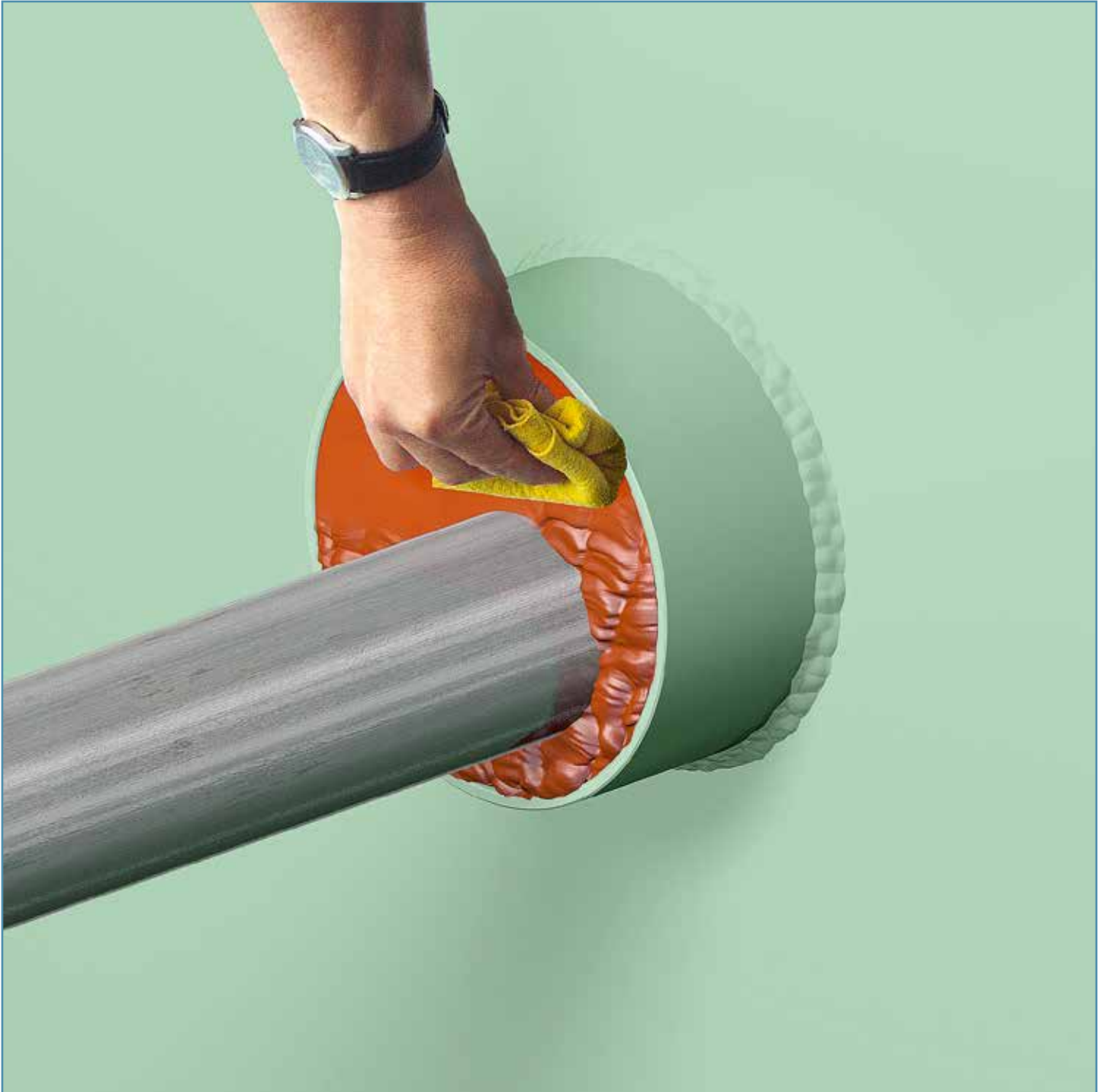

The cloth is then used to press down the sealant layer flush with the end of the transit frame. It is of utmost importance to ensure that the sealant is pressed very tightly so that the sealant is compressed into all empty spaces of the NOFIRNO® sleeve set, including partially into the hollow filler sleeves. The larger the adhesive surfaces of the sealant, the higher the performance of the system.

## INSTALLATION INSTRUCTIONS FOR NOFIRNO® SINGLE PIPE TRANSIT SEALING SYSTEM



The surface can be smoothed by hand. Just wet the hands thoroughly with water. No dirty hands when working with NOFIRNO® and a very neat surface is the result. Note: this should only be a smoothing procedure. Do not pack or compress the sealant further when using soap water.

Wear protective gloves when working with NOFIRNO® sealant. Please refer to the Safety Data Sheet for more information.

## INSTALLATION INSTRUCTIONS FOR NOFIRNO® SINGLE PIPE TRANSIT SEALING SYSTEM

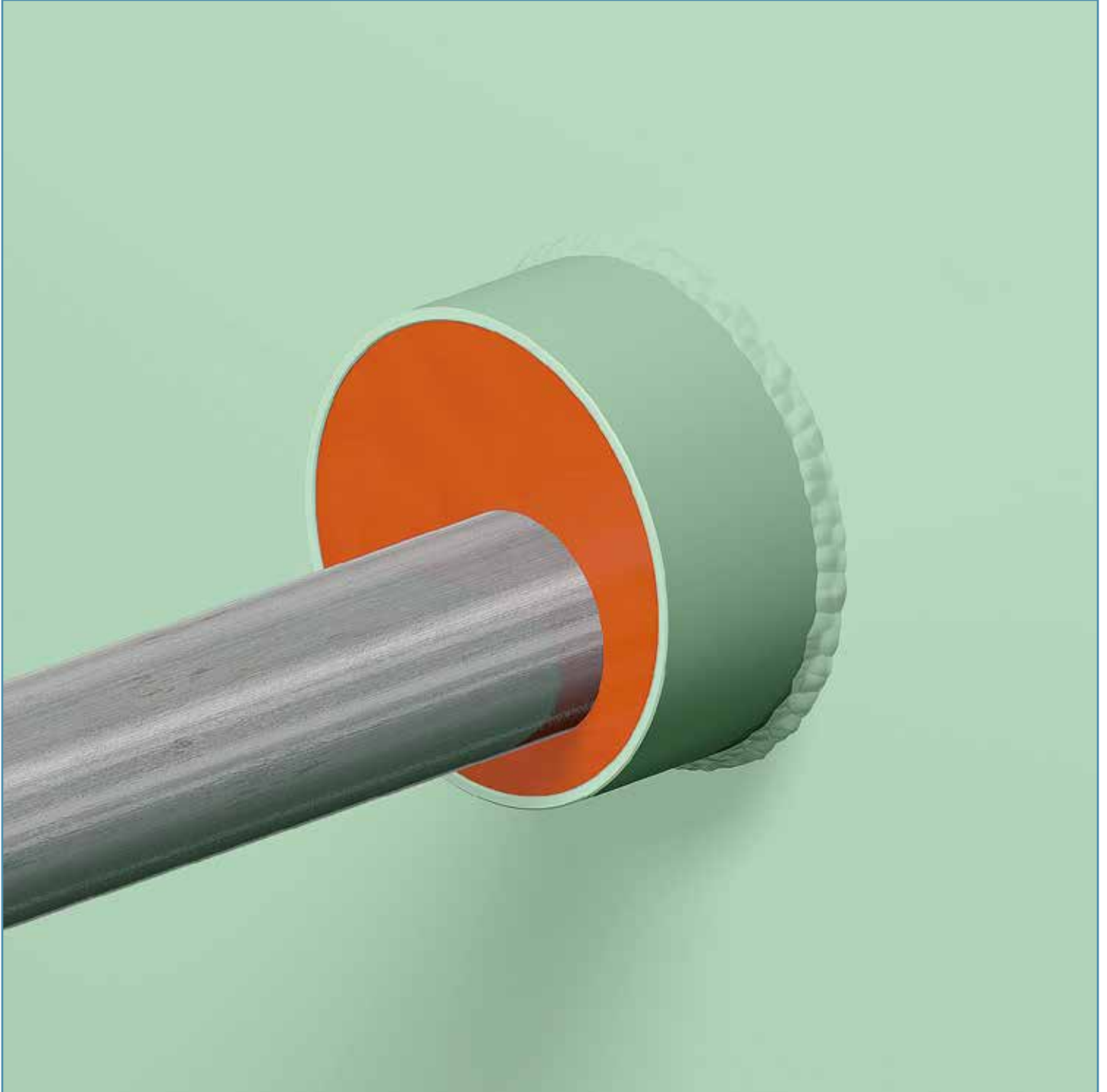

To obtain optimum adhesion during the curing process of the sealant, the pipe should be tightly fixed at both sides of the transit, as close as possible to the transit, and immediately after finishing the transit. Movement of the pipe during the curing process will impair the adhesion process to the surface of the pipe. Note: time needed for curing of the sealant is dependent on air humidity in combination with the environmental temperature. It is advisable to place a sticker near the finished transit, stating that the transit has been recently installed, and should not be touched or damaged.

## INSTALLATION INSTRUCTIONS FOR NOFIRNO® SINGLE PIPE TRANSIT SEALING SYSTEM

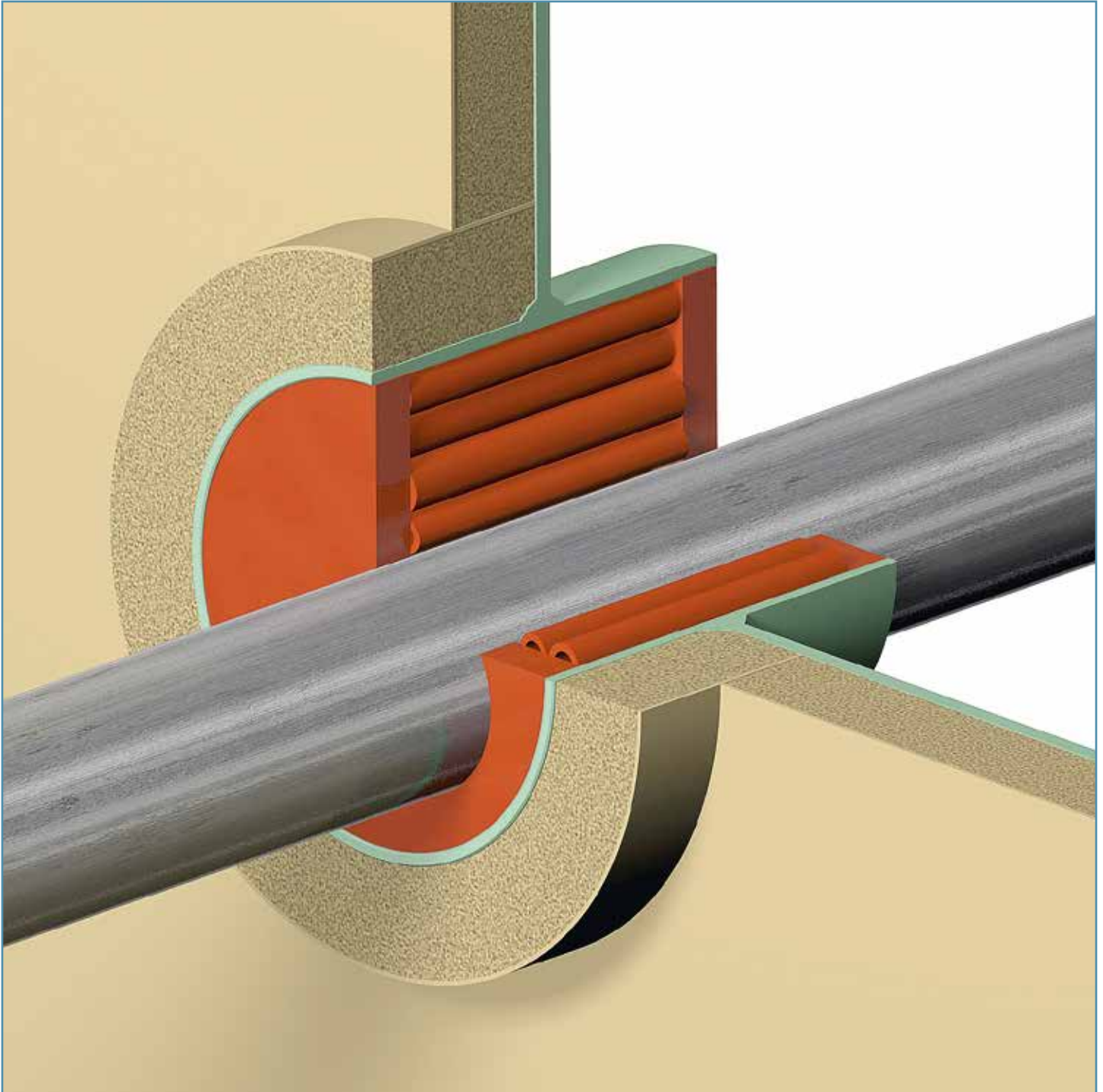

For A-class penetrations (which are insulated), the NOFIRNO® multi-pipe transit frame needs to be insulated only at the insulated side of the bulkhead or the lower side of the deck. Also approved for A-0 penetrations. Check the Type Approval Certificates for the insulation lengths to be applied around the ducted pipes to fulfil the criteria of the maximum temperature rise for A-class penetrations according to the FTP code. MED certificate 192130009AA04 issued by KIWA Netherlands. No metal parts are incorporated in the sealing system. The conduit frames cannot corrode inside due to the tight sealant layers at both sides of the transit. No CUI (Corrosion Underneath Insulation).

## INSTALLATION INSTRUCTIONS FOR NOFIRNO® SINGLE PIPE TRANSIT SEALING SYSTEM

**direction of exposure:  
fire from either side**

Minimum clearance between  
conduit sleeve and ducted pipe:

|                |       |
|----------------|-------|
| OD pipe        |       |
| up to 3"       | 15 mm |
| ≥3" up to 8"   | 20 mm |
| ≥8" up to 12"  | 30 mm |
| ≥12" up to 14" | 35 mm |
| ≥14" up to 16" | 40 mm |

**NOFIRNO SEALING SYSTEM**  
for steel/ss/CuNi & GRP pipes  
min. 1/16" - max. 16" NPS

For application in aluminium partitions:  
Aluminium core to be insulated as not to  
exceed a core temperature of 150 °C.  
For fire from either side insulation to be  
applied on both sides.  
See paragraph in MED certificate.

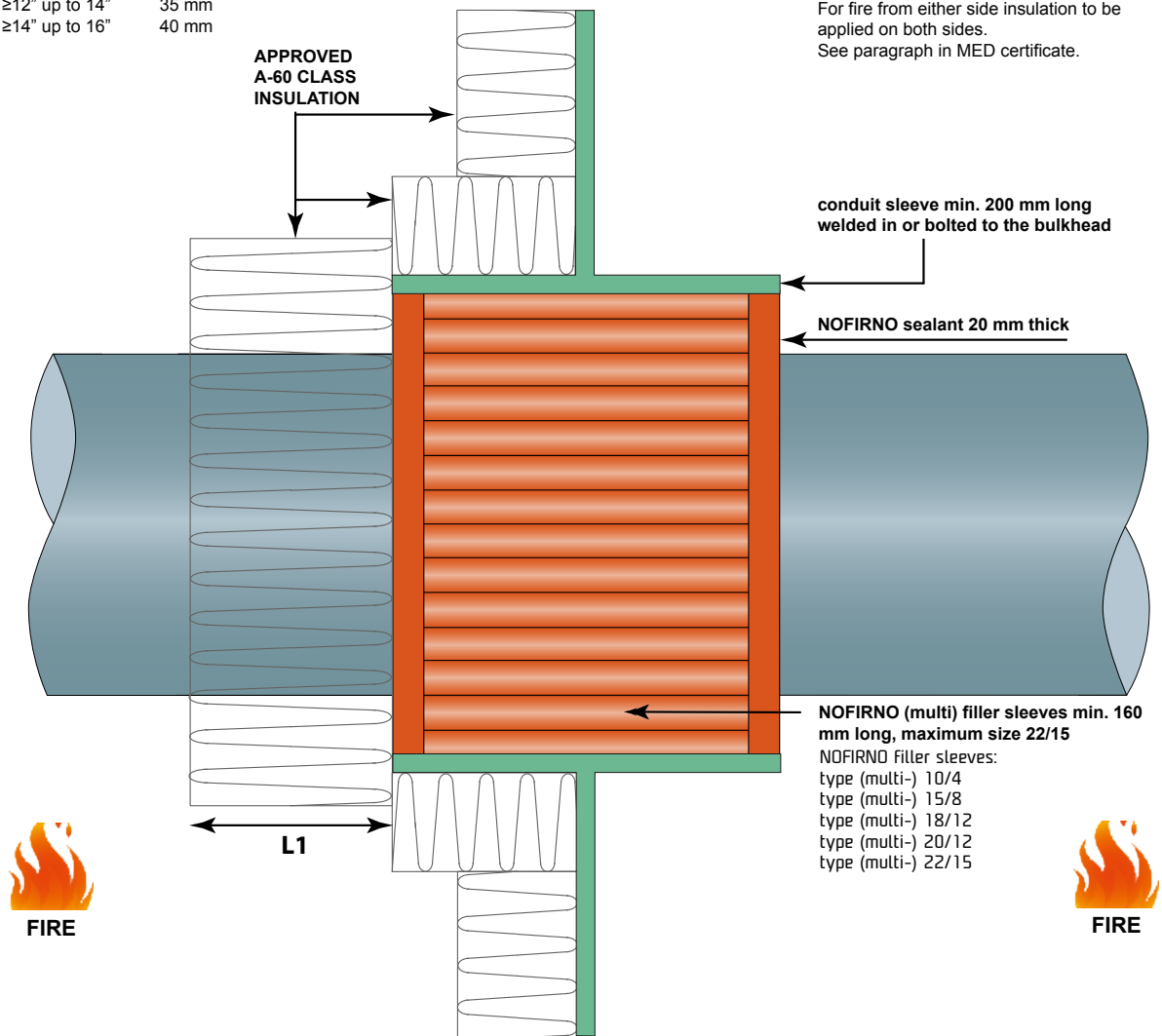

L1 = min. length of Insulation around ducted pipe:

|                           |         |
|---------------------------|---------|
| steel/ss/CuNi & GRP pipes |         |
| up to 1"                  | 200 mm  |
| ≥1" up to 3"              | 350 mm  |
| ≥3" up to 6"              | 500 mm  |
| ≥6" up to 10"             | 700 mm  |
| ≥10" up to 14"            | 900 mm  |
| ≥14" up to 16"            | 1200 mm |

**conduit sleeve positioned:**  
- symmetrical  
or  
- non-symmetrical with longest  
length on insulated side



Description: NOFIRNO sealing system for A60 class bulkheads

Mat.: NOFIRNO sleeves/sealant

Ref.: JAB

Date:

14-10-2019

Scale:

*No part of this document may be reproduced by photocopy,  
print, microfilm or any means without the written permission  
of BEELE Engineering bv of The Netherlands*

Rev. 1

05-03-2020

Rev. 2

02-04-2020

**NFN 130E**

## INSTALLATION INSTRUCTIONS FOR NOFIRNO® SINGLE PIPE TRANSIT SEALING SYSTEM

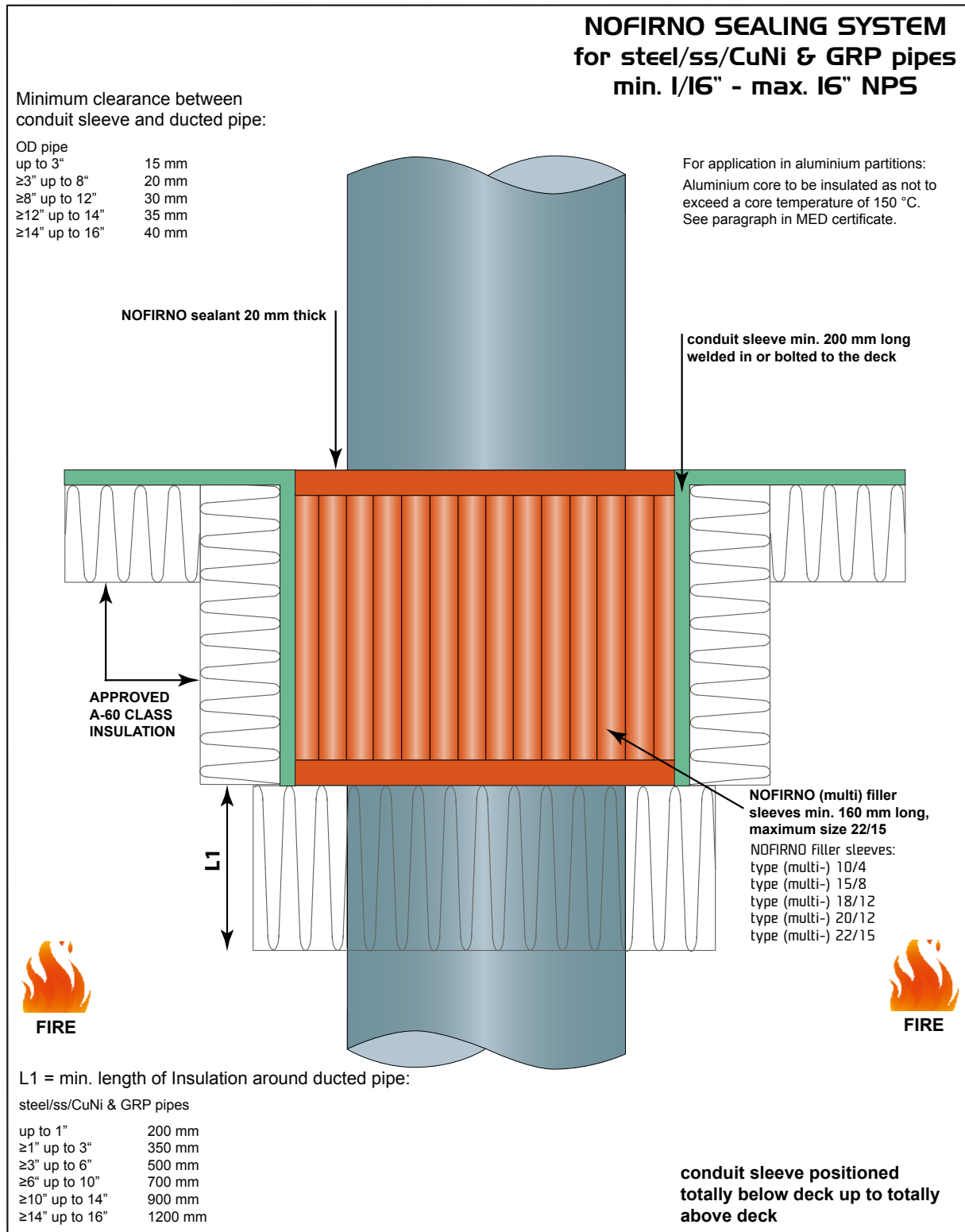

|  |   |            |          |  |
|--|---|------------|----------|--|
|  | Description: NOFIRNO sealing system for A60 class decks |            |          |  |
|  | Mat.: NOFIRNO sleeves/sealant                           |            |          |  |
| Ref.: JAB  | Date:   | 14-10-2019 | Scale:   |  |
| No part of this document may be reproduced by photocopy, print, microfilm or any means without the written permission of BEELE Engineering bv of The Netherlands | Rev. 1  | 05-03-2020 | NFN 131E |  |
|  | Rev. 2  | 02-04-2020 |          |  |

## INSTALLATION INSTRUCTIONS FOR NOFIRNO® SINGLE PIPE TRANSIT SEALING SYSTEM

**direction of exposure:  
fire from either side**

Minimum clearance between  
conduit sleeve and ducted pipe:

|                |       |
|----------------|-------|
| OD pipe        |       |
| up to 3"       | 15 mm |
| ≥3" up to 8"   | 20 mm |
| ≥8" up to 12"  | 30 mm |
| ≥12" up to 14" | 35 mm |
| ≥14" up to 16" | 40 mm |

**NOFIRNO SEALING SYSTEM**  
for steel/ss/CuNi & GRP pipes  
min. 1/16" - max. 16" NPS

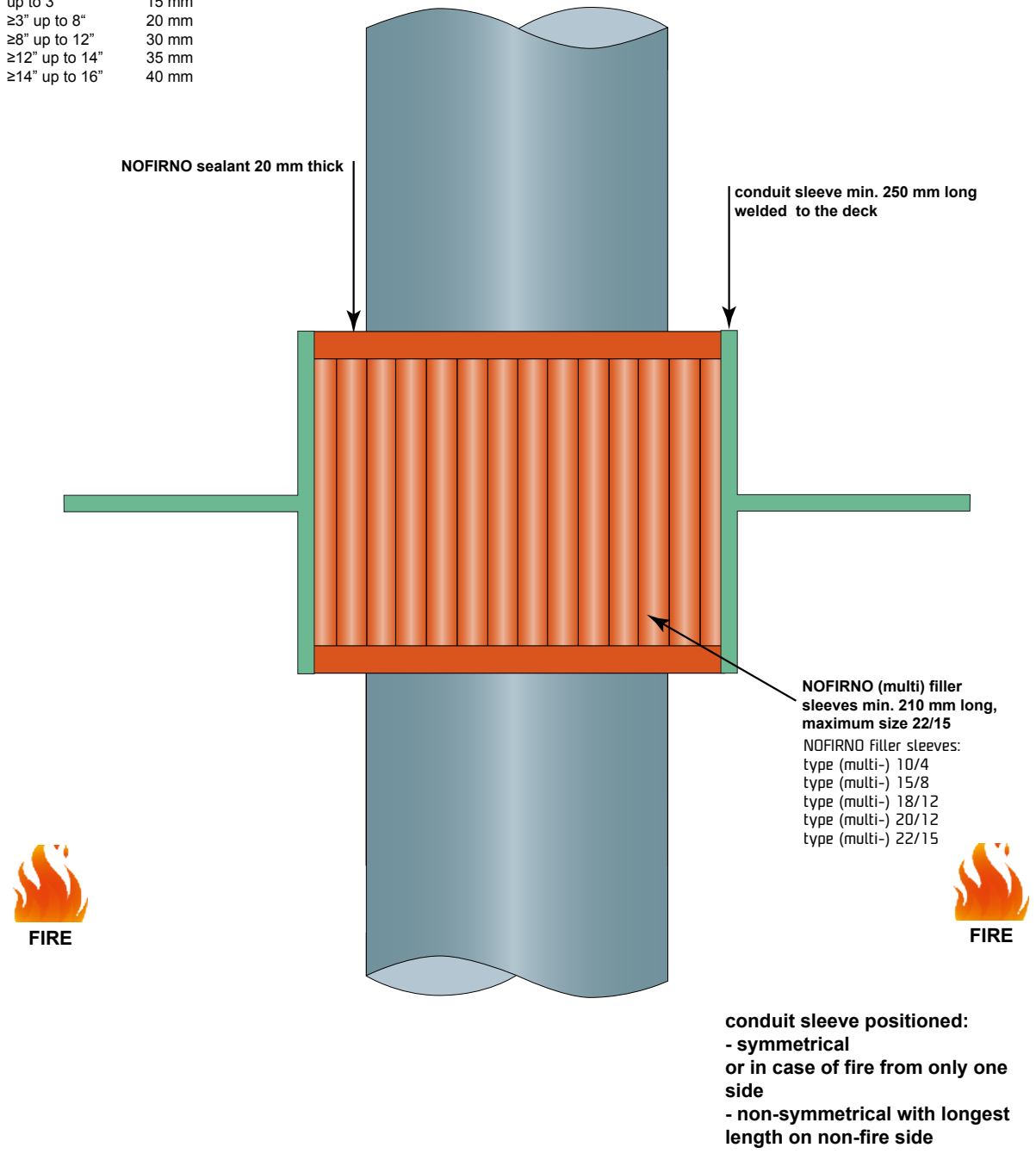

|   |  |            |                 |  |
|---|--|------------|-----------------|--|
|    | Description: NOFIRNO sealing system for A0 class decks |            |                 |  |
|   | Mat.: NOFIRNO sleeves/sealant                          |            |                 |  |
| Ref.: JAB   | Date:  | 14-10-2019 | Scale:          |  |
| <i>No part of this document may be reproduced by photocopy, print, microfilm or any means without the written permission of BEELE Engineering bv of The Netherlands</i> | Rev. 1   | 22-01-2020 | <b>NFN 133E</b> |  |
|   | Rev. 2   | 02-04-2020 |                 |  |

## INSTALLATION INSTRUCTIONS FOR NOFIRNO® MULTI-PIPE TRANSIT SEALING SYSTEM



NOFIRNO® is approved also for multi-pipe transits. The transit frames might be welded into the partition long before pipe ducting will start. For this reason, the condition of the inside of the frame/sleeve has to be checked when starting pipe ducting. Before insertion of the NOFIRNO® filler sleeves, the inside of the transit frames has to be cleaned, and any dirt, oil, grease and other residues or corrosion should be removed from the inside of the transit frame.

Note: For fire resistant penetrations the max. size of the transit frame is 600x300 mm or equivalent of 1800 cm<sup>2</sup>. Multi-mix pipe/cable penetrations max. size 1000x300 mm.

**INSTALLATION INSTRUCTIONS FOR NOFIRNO®  
MULTI-PIPE TRANSIT SEALING SYSTEM**



With a steel brush or by blasting, the corroded inner surface of the transit frame should be treated to remove these corroded spots. The excellent adhesive properties of the sealing system will be diminished by corroded surfaces.

## INSTALLATION INSTRUCTIONS FOR NOFIRNO® MULTI-PIPE TRANSIT SEALING SYSTEM



The NOFIRNO® sealing system is composed of (multi-) filler sleeves, and layers of sealant. The sleeves are the backing on which the sealant is going to be applied. A 20 mm thick layer of sealant is applied at both sides of the penetration. Before welding the transit frame into the partition, check if the transit frame is deep enough to be in line with the certification of the sealing system. The NOFIRNO® filler sleeves are 40 mm shorter in length than the depth of the transit frame. Note: for high rated watertight penetrations, the transit frame should be either of a limited size or partitions should be placed inside the larger transit frames to divide the frame in smaller sections.

**INSTALLATION INSTRUCTIONS FOR NOFIRNO®  
MULTI-PIPE TRANSIT SEALING SYSTEM**

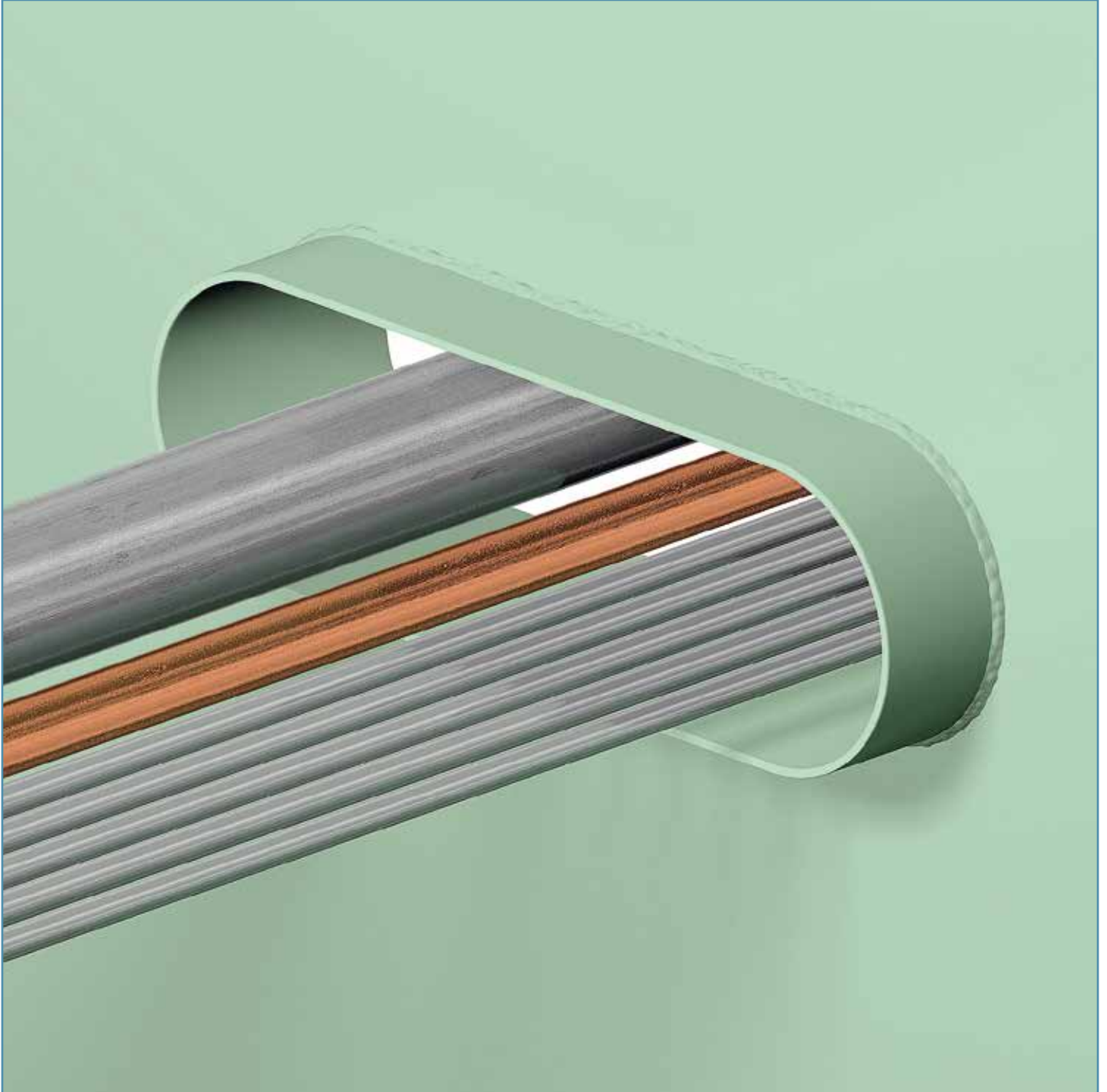

The pipes can be ducted through the transit frame in random order. It is most important that they are ducted with the required interspace according to the certified drawings, and with not less than the minimum allowable distance to the wall of the conduit frame.

**INSTALLATION INSTRUCTIONS FOR NOFIRNO®  
MULTI-PIPE TRANSIT SEALING SYSTEM**

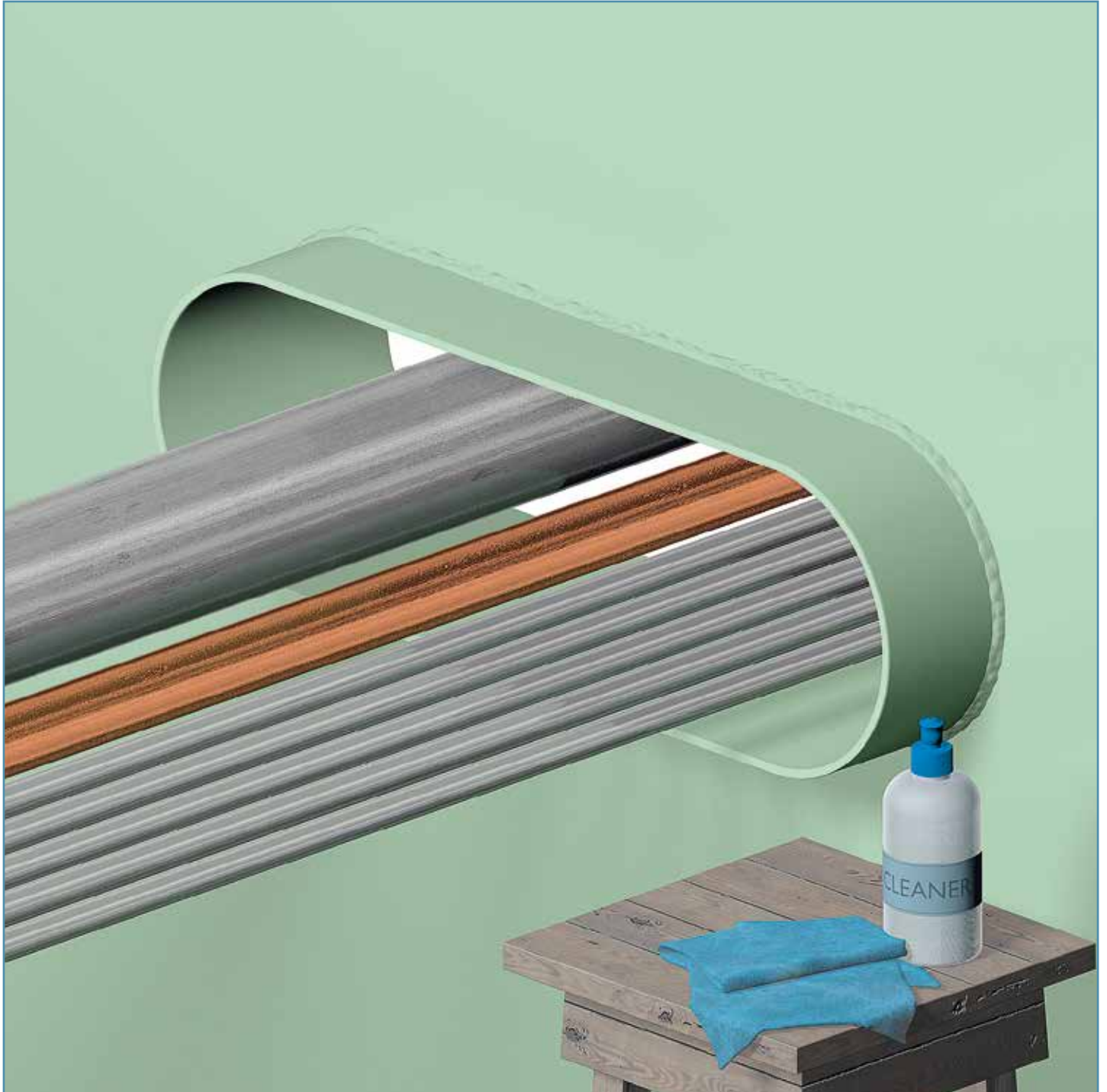

For adequate cleaning purposes (which is an important step), sufficient separation of the ducted pipes and access to the wall of the conduit frame is of utmost importance.

## INSTALLATION INSTRUCTIONS FOR NOFIRNO® MULTI-PIPE TRANSIT SEALING SYSTEM

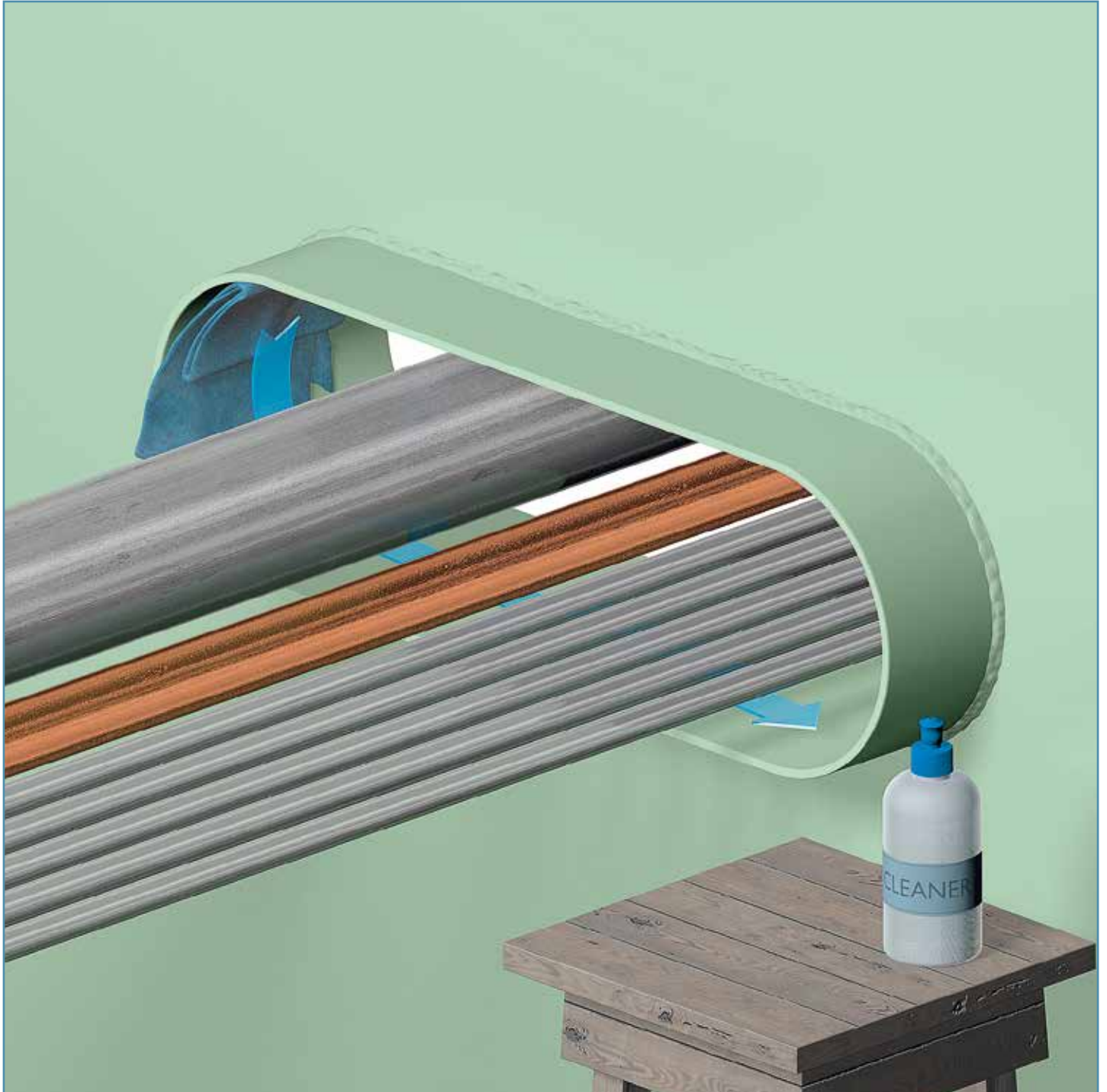

Final sealing of the pipe penetration may be quite some time after ducting the pipes. In such a situation, the status of the inside of the transits frames has to be checked again when starting with the installation of the sealing system. Clean the inside of the transit frames thoroughly and remove any dirt, oil, grease and other residues or corrosion from the inside of the transit frame.

**INSTALLATION INSTRUCTIONS FOR NOFIRNO®  
MULTI-PIPE TRANSIT SEALING SYSTEM**

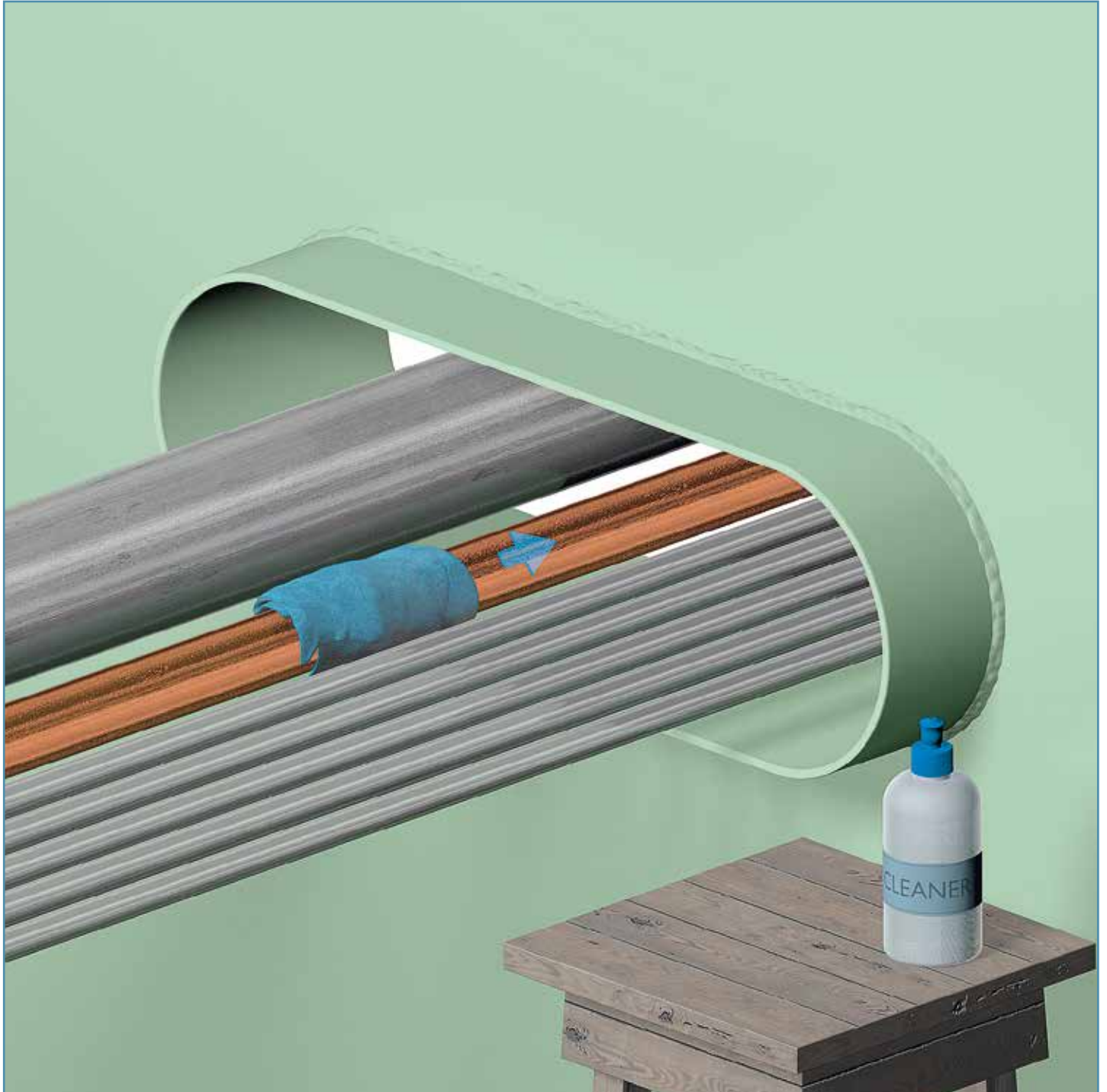

Clean and dry the pipes thoroughly in a similar way. Any moisture, dirt or oil residues will have a negative impact on the adhesive properties of the NOFIRNO® sealant to be applied after filling the transit frame.

**INSTALLATION INSTRUCTIONS FOR NOFIRNO®  
MULTI-PIPE TRANSIT SEALING SYSTEM**

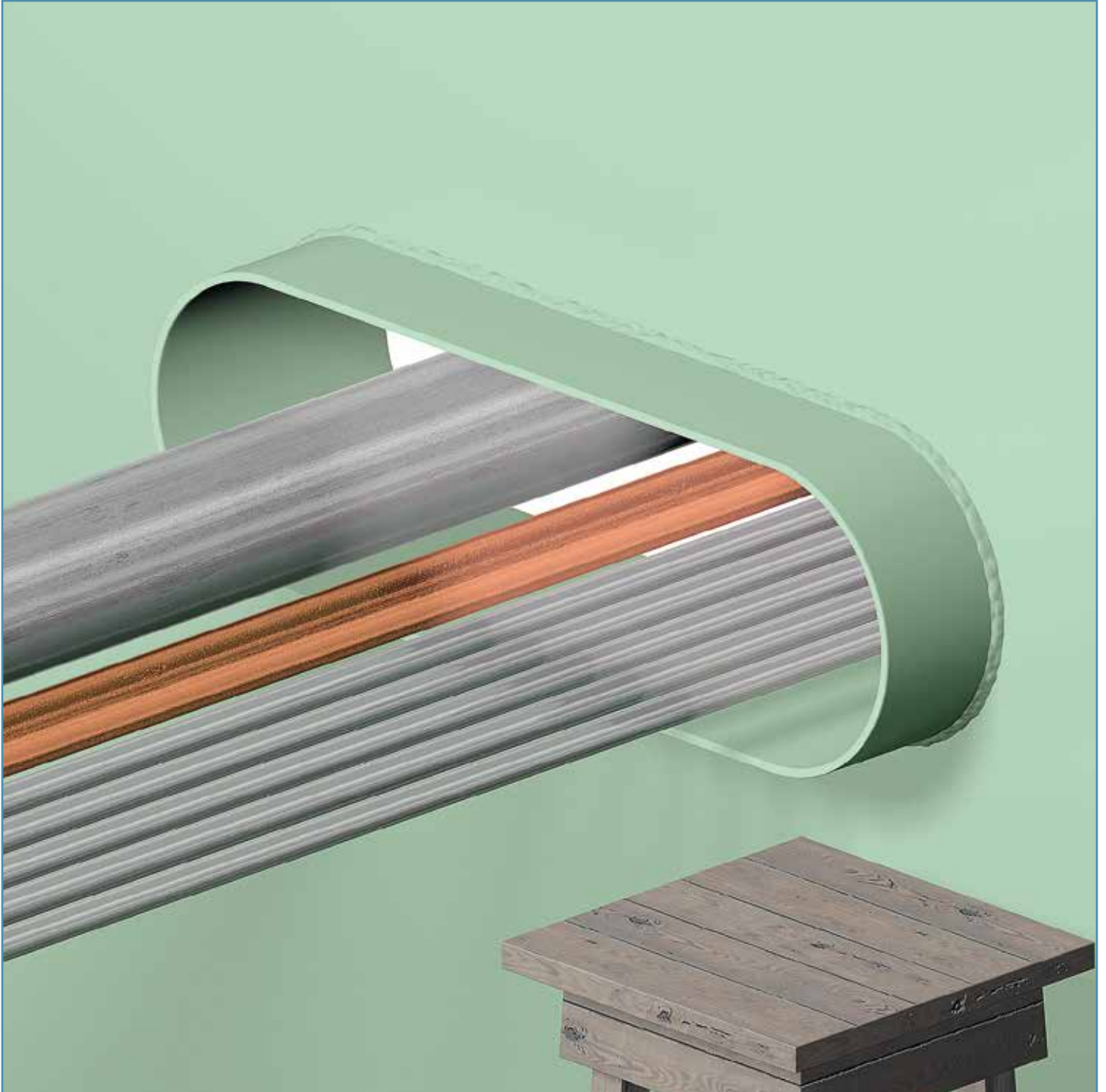

The pipes have to be cleaned at the spot where the sealant is applied in a later stage. This means 20 mm at both sides of the transit. If feasible, it is of course easier to clean the pipes over their full length inside the transit.

**INSTALLATION INSTRUCTIONS FOR NOFIRNO®  
MULTI-PIPE TRANSIT SEALING SYSTEM**

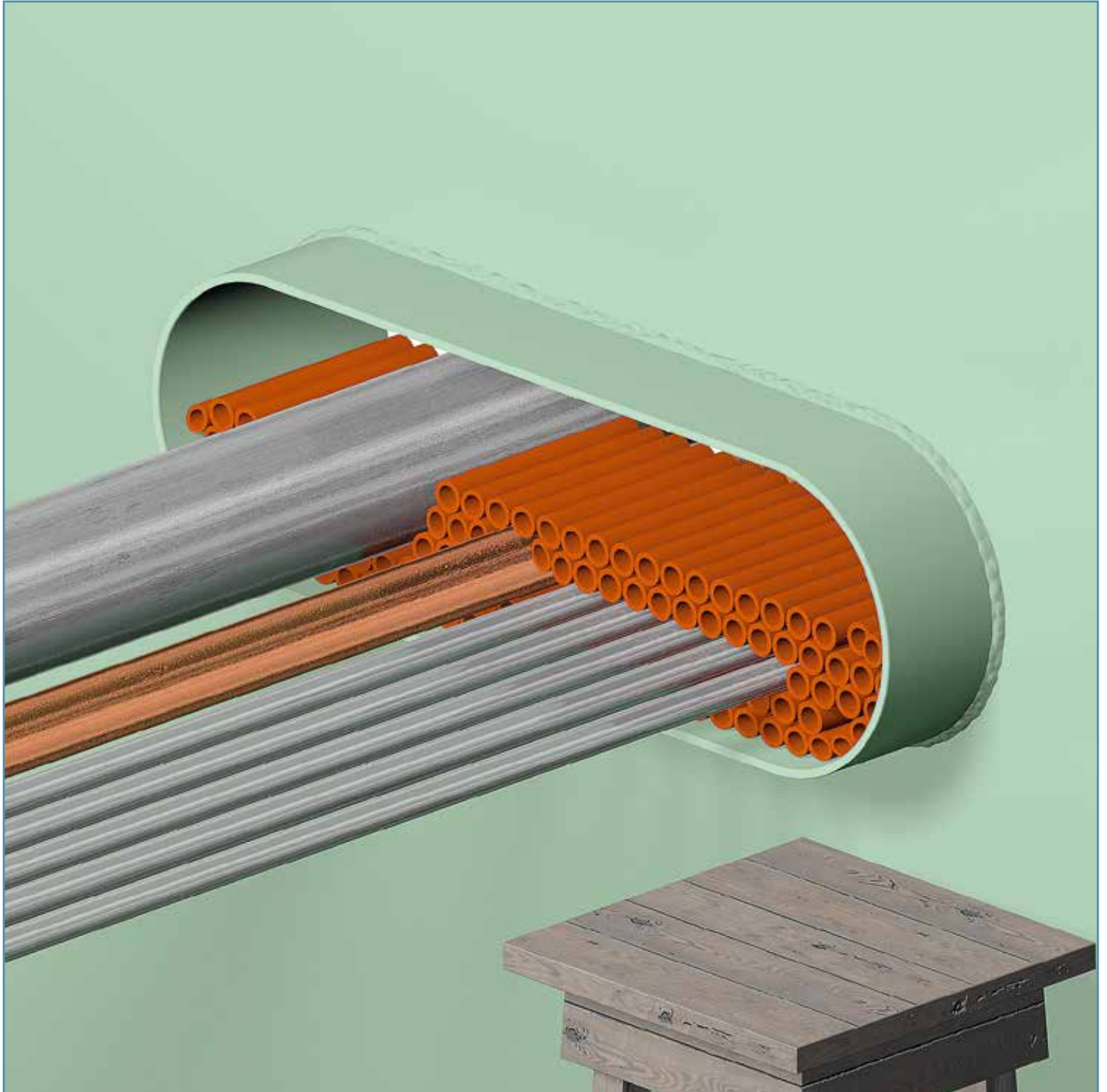

For later extensions, it is advisable to use NOFIRNO® single filler sleeves, since they are easier to remove when a new pipe has to be ducted.

## INSTALLATION INSTRUCTIONS FOR NOFIRNO® MULTI-PIPE TRANSIT SEALING SYSTEM

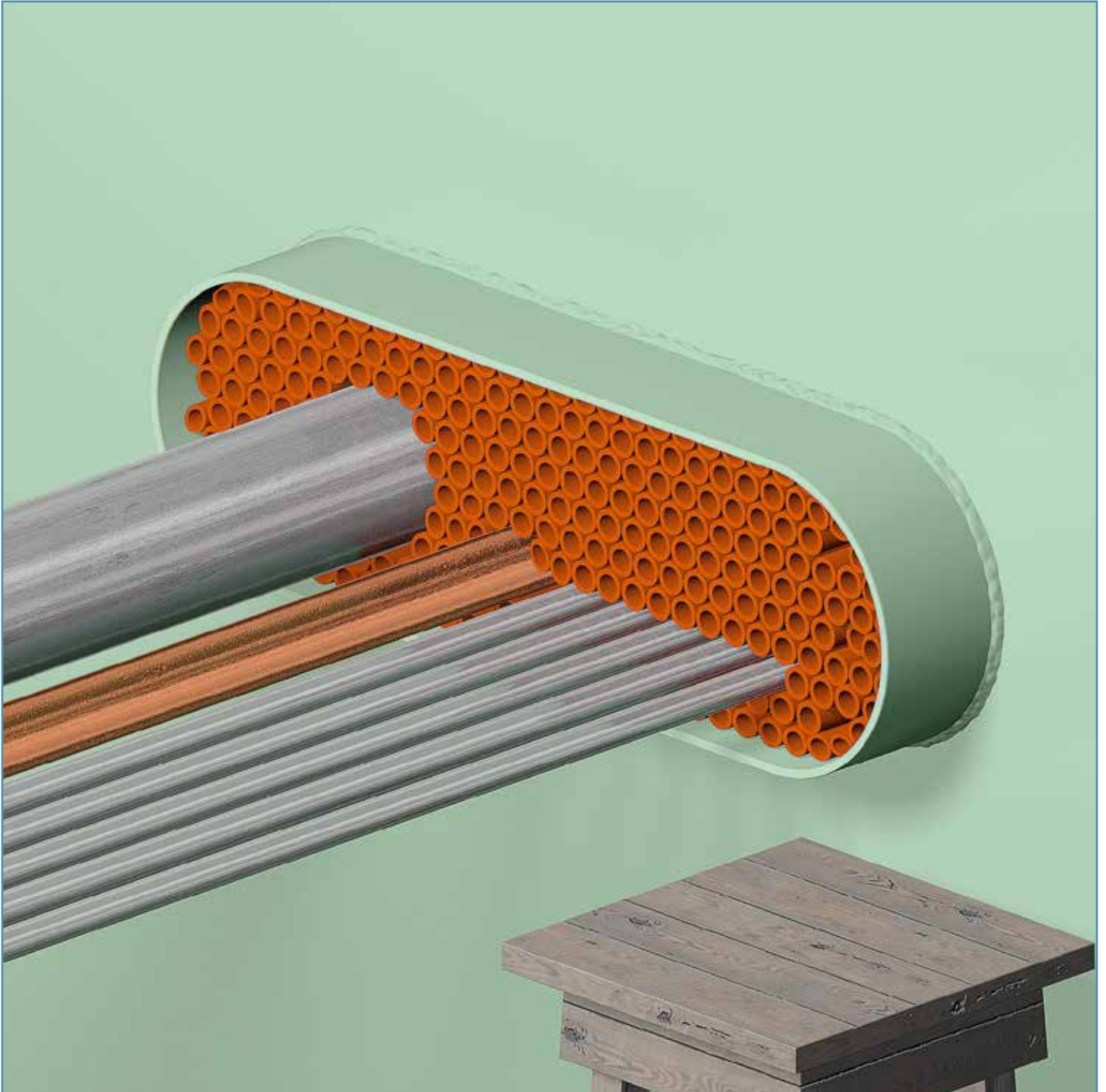

After using the multi-sets of filler sleeves 22/15 openings will be left in the set of fillers. These have to be filled. A tight fit of the filling is a necessity to improve overall mechanical stability. Especially in the case of watertight penetrations.

## INSTALLATION INSTRUCTIONS FOR NOFIRNO® MULTI-PIPE TRANSIT SEALING SYSTEM

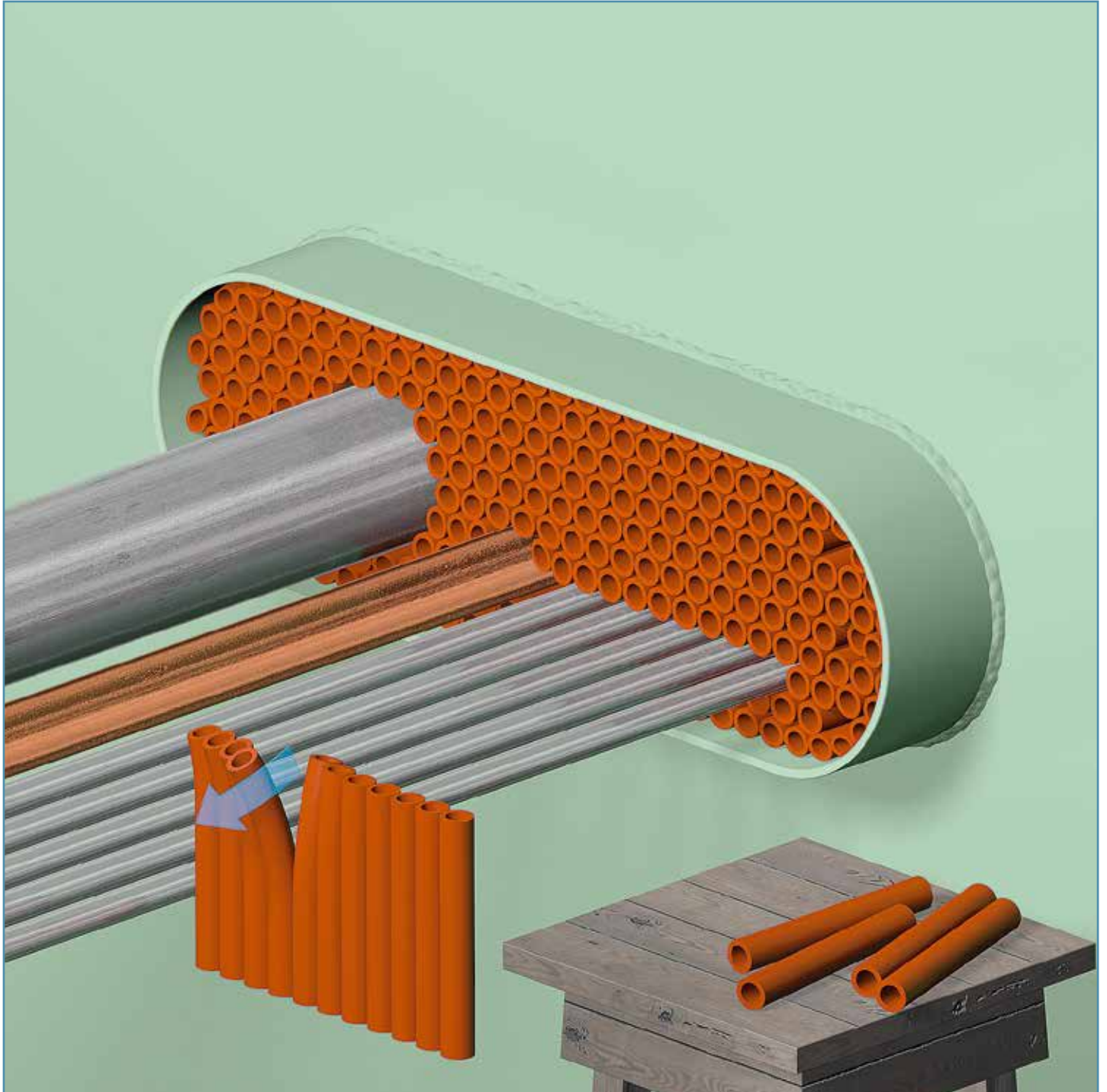

The smaller openings are now filled with parts of the sets of multi-filler sleeves. To tear off sleeves from the multi-set, the procedure is to do this backwards/forwards and not sideways. This is because of the strength of the intermediate rubber parts.

Push the filler sleeves into the transit frame in such a way as to leave about 20 mm free space at the front and the back. The insertion does not have to be precise in this regard. Adjustment of the set of sleeves to the 20 mm recess can be carried out just before applying the sealant.

## INSTALLATION INSTRUCTIONS FOR NOFIRNO® MULTI-PIPE TRANSIT SEALING SYSTEM

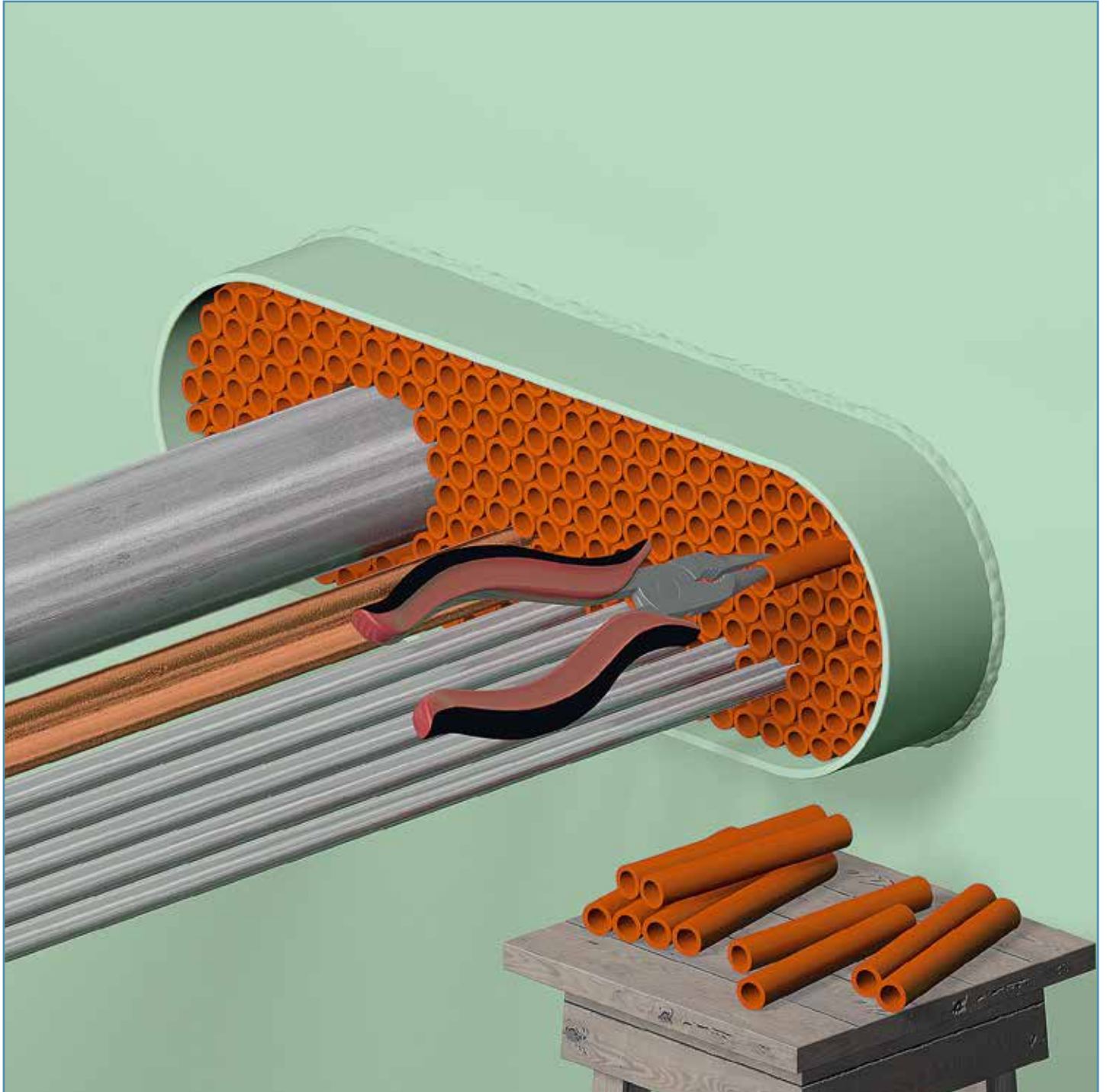

With a flat nose pliers, NOFIRNO® single filler sleeves are inserted in the remaining smaller open spaces in the set of fillers. Some smaller openings in the set of filler sleeves have to be filled with smaller types of filler sleeves 10/4, 15/8, and 18/12 to obtain a tight fit of the filling. Furthermore, a very tight fit of the filling is vital to the performance of the sealing system.

**INSTALLATION INSTRUCTIONS FOR NOFIRNO®  
MULTI-PIPE TRANSIT SEALING SYSTEM**

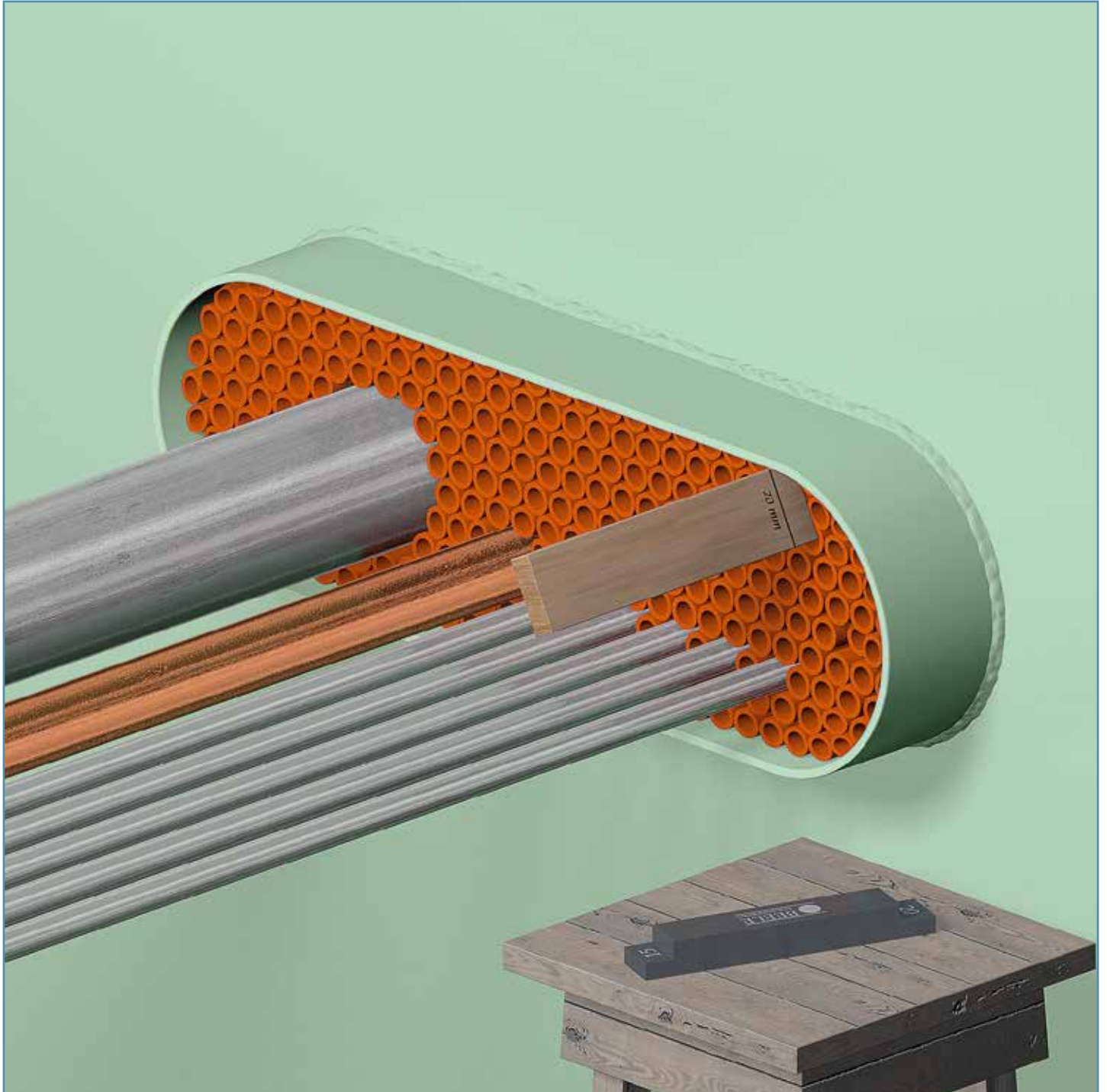

With a piece of wood marked with the required 20 mm depth, or with the aluminum adjuster developed by BEELE Engineering, the set of fillers can be adjusted to the required 20 mm recess inside the transit. Use a plastic hammer to adjust the set of filler sleeves with the NOFIRNO® adjuster.

**INSTALLATION INSTRUCTIONS FOR NOFIRNO®  
MULTI-PIPE TRANSIT SEALING SYSTEM**

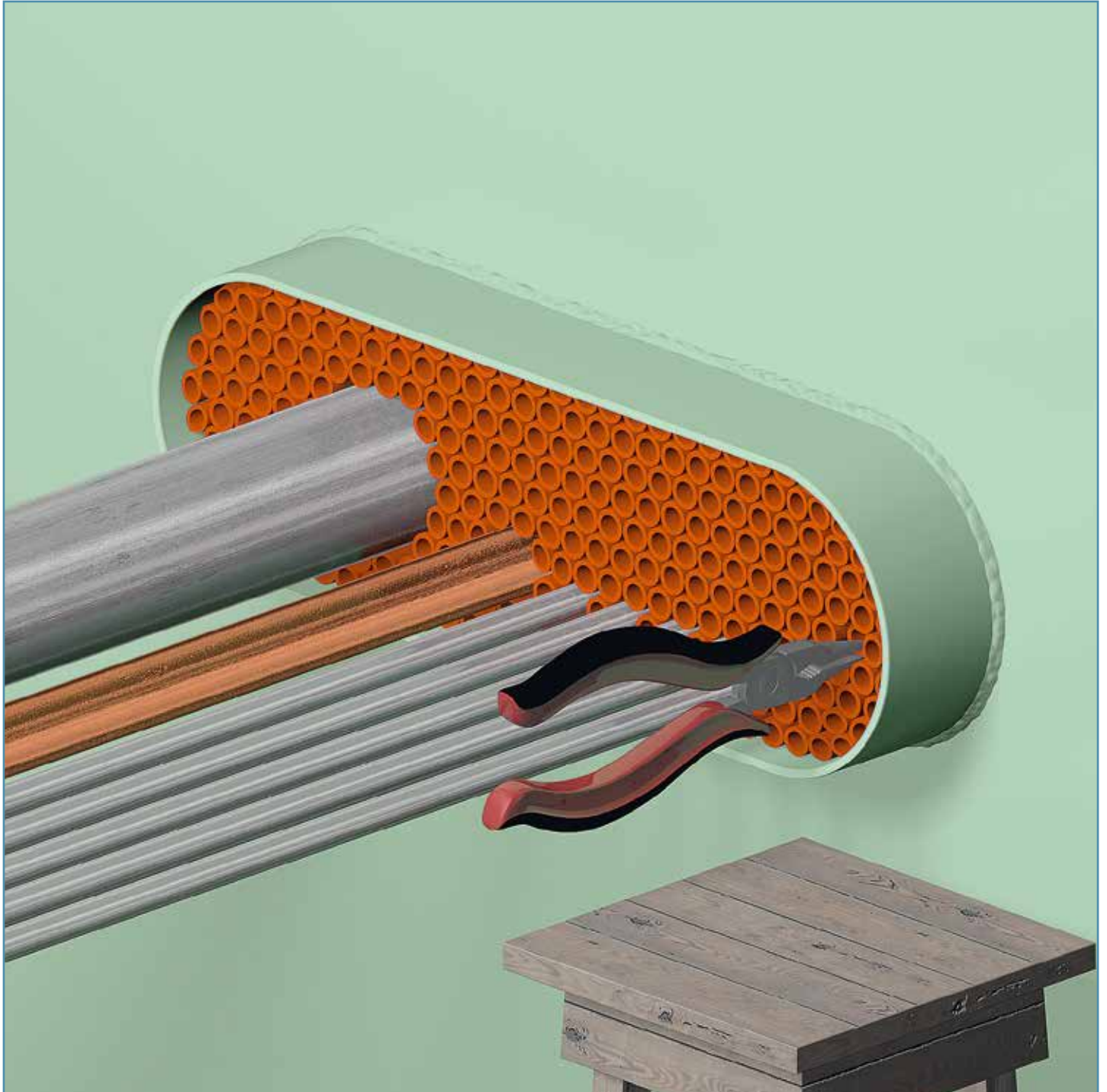

The filler set can be further adjusted with the aid of a flat nose pliers. Single filler sleeves sometimes might be inserted too deep. A ca. 20 mm free space at the front and back of the sealing system (+/- 2 mm tolerance is acceptable) is a must to obtain optimum sealing capacity of the sealing system.

## INSTALLATION INSTRUCTIONS FOR NOFIRNO® MULTI-PIPE TRANSIT SEALING SYSTEM

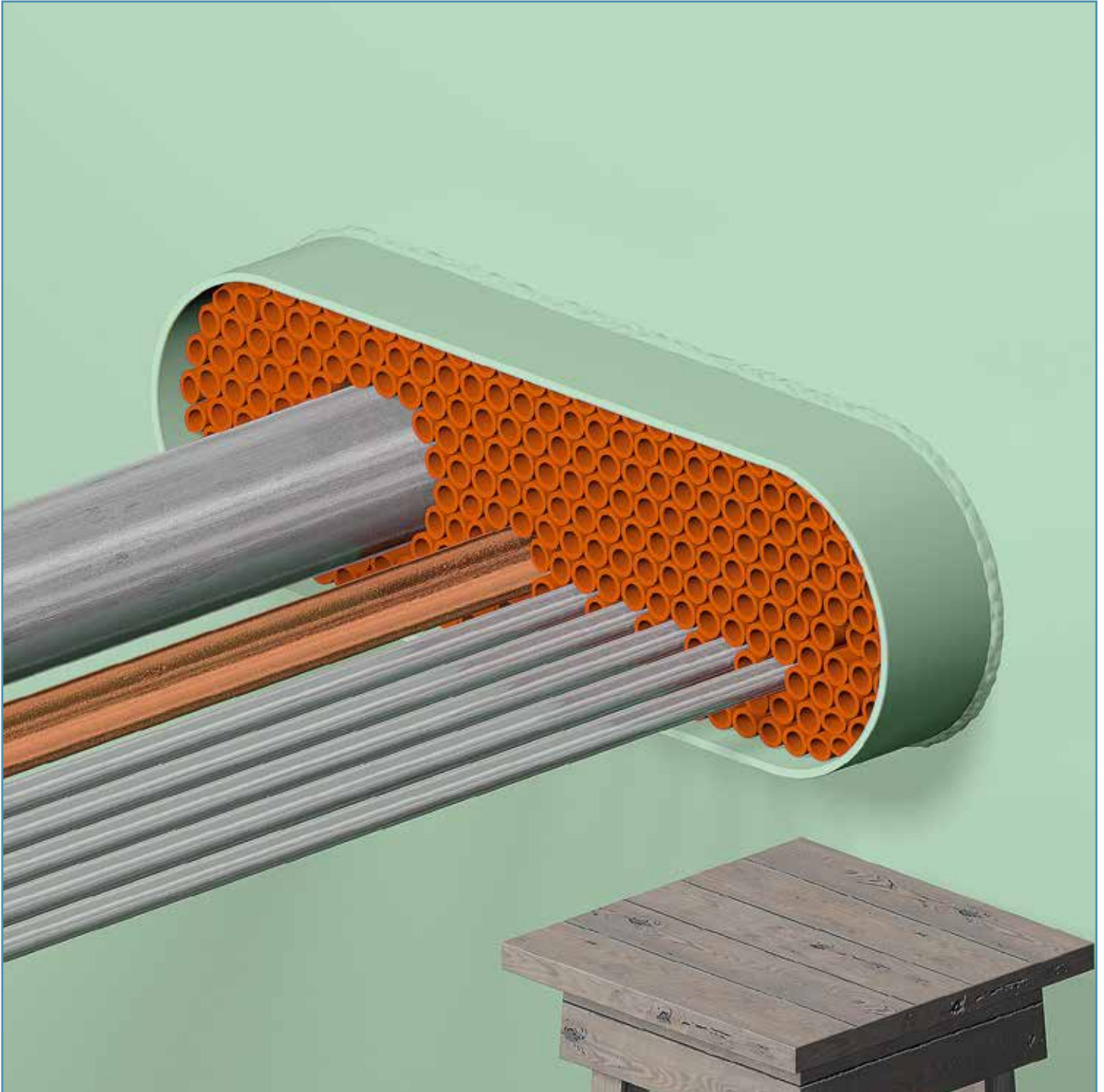

Before applying the NOFIRNO® sealant, it is advisable to perform a final check on the packing of insert and filler sleeves. A tight fit of the whole set of sleeves, in the required ratio, is not only vital for the mechanical stability of the sealing system, but also for the fire stopping properties. A final check should therefore be a part of quality control.

## INSTALLATION INSTRUCTIONS FOR NOFIRNO® MULTI-PIPE TRANSIT SEALING SYSTEM

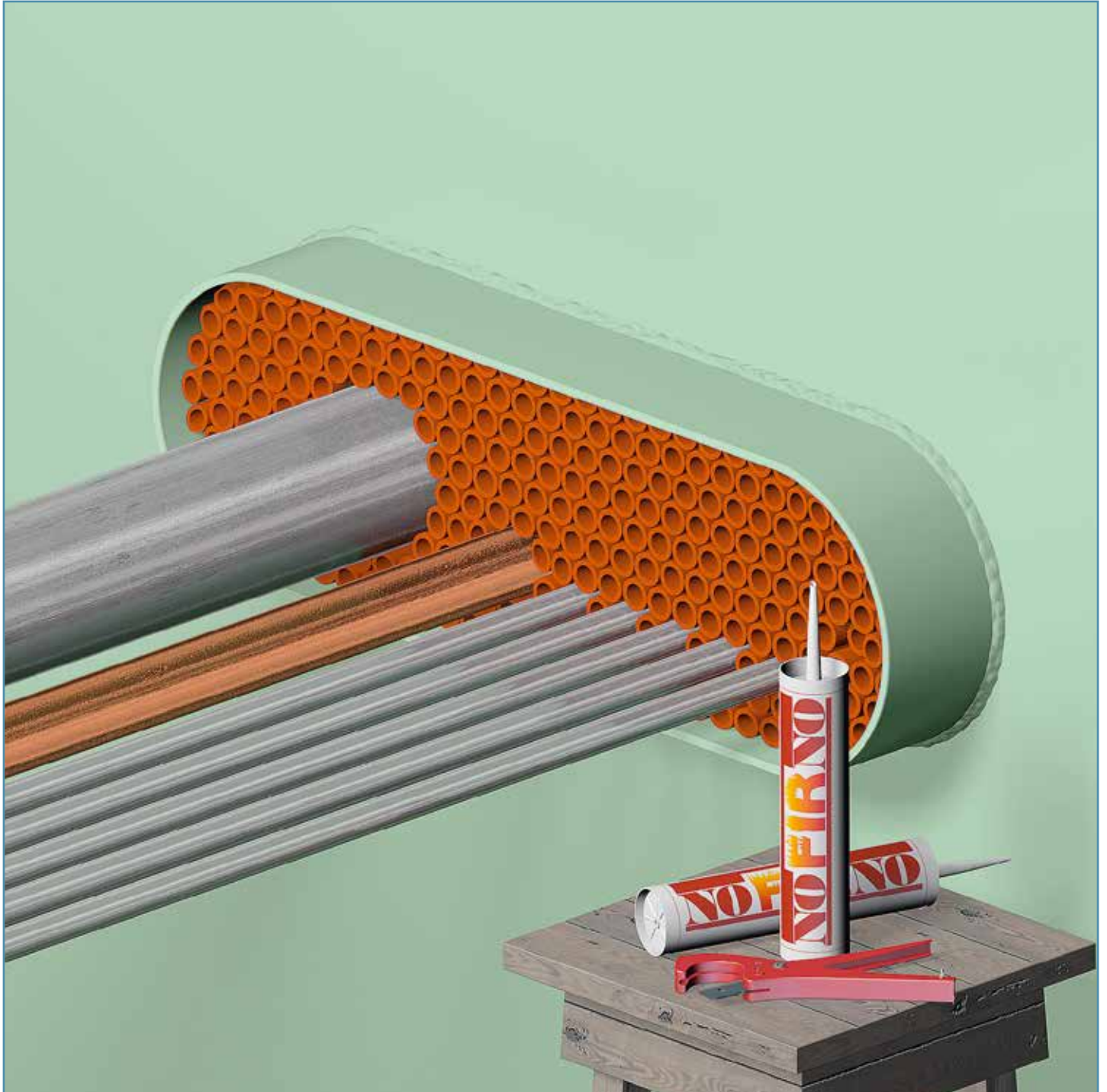

Final smoke, gas and watertight sealing of the NOFIRNO® multi-pipe transits is achieved with the application of NOFIRNO® sealant. NOFIRNO® sealant has proven excellent performance with regard to mechanical and fire resistance requirements. The NOFIRNO® sealing system has been successfully exposed to severe pressure, shock and vibration tests.

**INSTALLATION INSTRUCTIONS FOR NOFIRNO®  
MULTI-PIPE TRANSIT SEALING SYSTEM**



Cut the injection nozzles of the cartridges in an angled way to create a medium sized dispersing opening. This will improve the flow of the sealant in between the set of pipes. Furthermore, it is advisable to use professional sealant guns. Hand fatigue is prevented, and an optimum flow of the sealant is obtained. For larger penetrations, electric or pneumatic dispensers should be used.

## INSTALLATION INSTRUCTIONS FOR NOFIRNO® MULTI-PIPE TRANSIT SEALING SYSTEM



A 20 mm thick layer of NOFIRNO® sealant is applied at each side of the NOFIRNO® multi-pipe transit. NOFIRNO® sealant has an engineered viscosity, preventing the sealant from sagging and also allowing for a perfect flow of the sealant between the pipes during injection. For multi-pipe transits with a high filling rate, longer nozzles are available for the sealant cartridges.

Please refer to the Safety Data Sheet for more information about the working environment.

**INSTALLATION INSTRUCTIONS FOR NOFIRNO®  
MULTI-PIPE TRANSIT SEALING SYSTEM**



Skin formation of the sealant takes place after ca. 10-15 minutes. In case of larger transits with a low pipe filling rate, do not apply more sealant than can be finished within this time-frame.

**INSTALLATION INSTRUCTIONS FOR NOFIRNO®  
MULTI-PIPE TRANSIT SEALING SYSTEM**

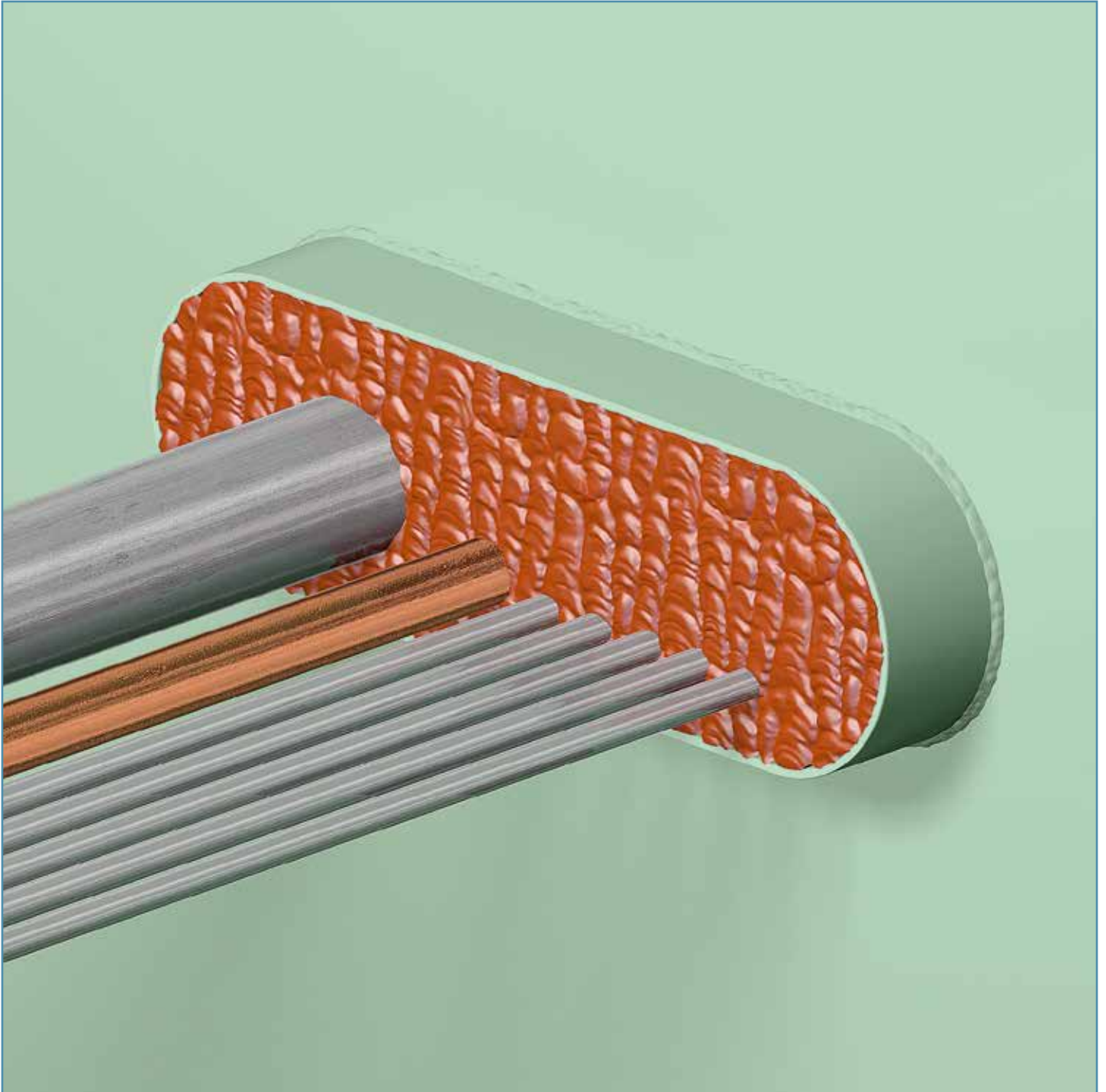

The multi-pipe transit should be overfilled with NOFIRNO® sealant, because some sealant will be pushed into the empty spaces between and into the hollow NOFIRNO® (multi) filler sleeves during further finishing. This will contribute also to obtain higher tightness ratings.

**INSTALLATION INSTRUCTIONS FOR NOFIRNO®  
MULTI-PIPE TRANSIT SEALING SYSTEM**



To smooth the surface of the NOFIRNO® sealant layer, a cloth is sprayed with water. This prevents the sealant from sticking to the cloth.

Please refer to the Safety Data Sheet for more information about the working environment.

**INSTALLATION INSTRUCTIONS FOR NOFIRNO®  
MULTI-PIPE TRANSIT SEALING SYSTEM**

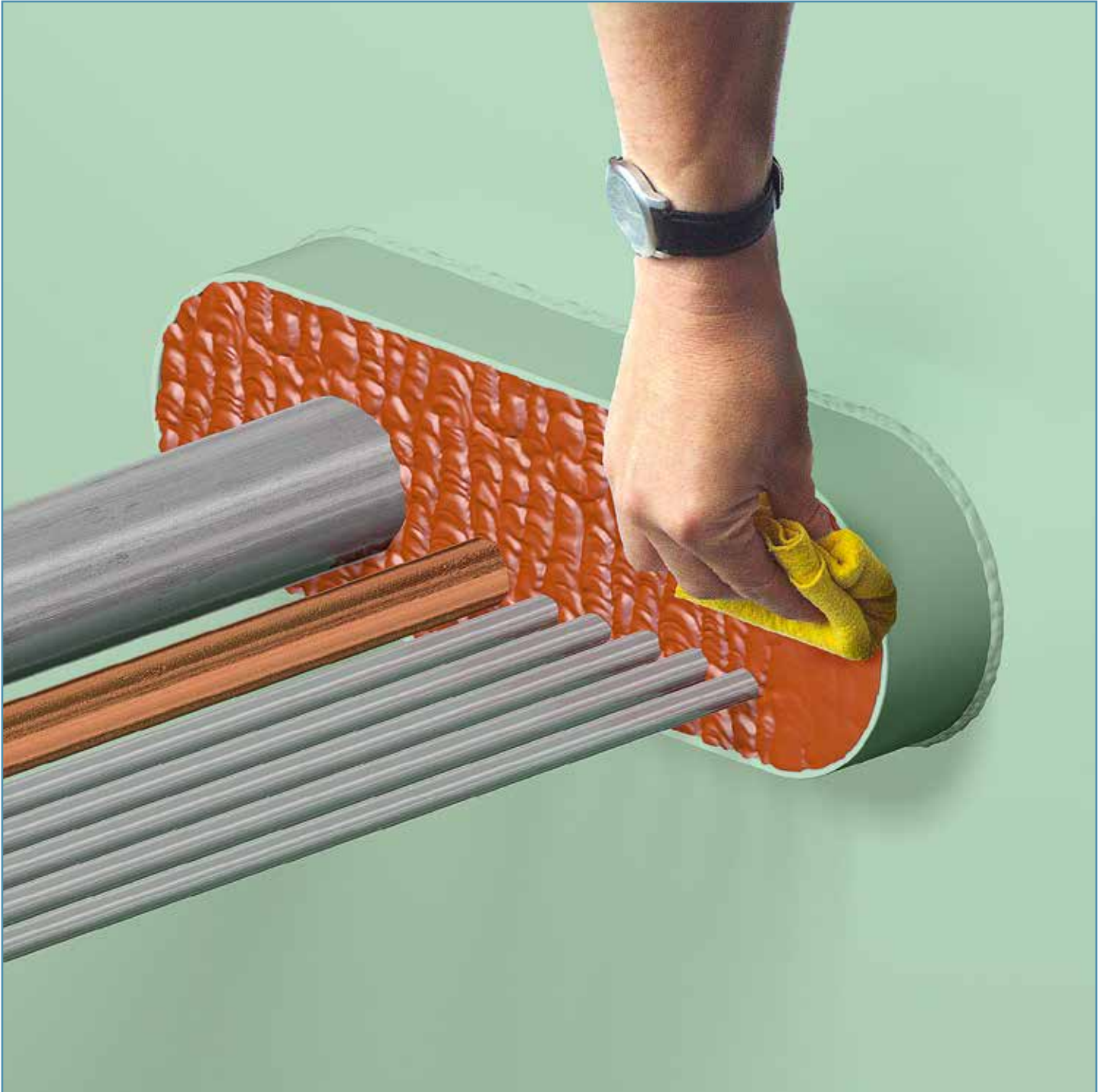

The cloth is then used to press down the sealant layer flush with the end of the transit frame. It is of utmost importance to ensure that the sealant is compressed very tightly so that the sealant is compressed into all empty spaces of the NOFIRNO® filler sleeve set, including partially into the hollow filler sleeves. The larger the adhesive surfaces of the sealant, the higher the performance of the system. The system can also be used for steam lines having temperatures up to +180° C.

## INSTALLATION INSTRUCTIONS FOR NOFIRNO® MULTI-PIPE TRANSIT SEALING SYSTEM

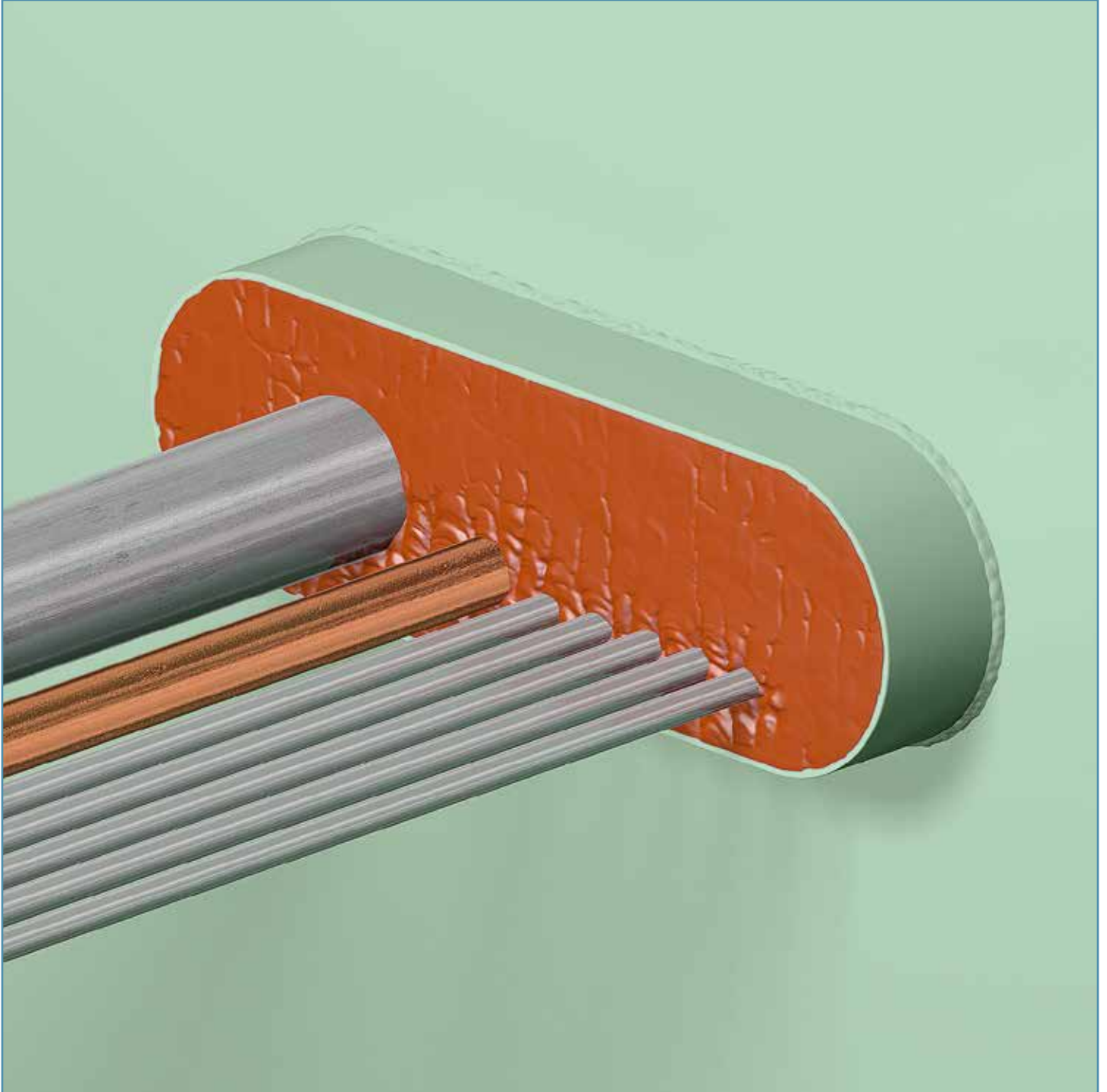

Due to the rapid skin formation of the sealant, smoothing should take place directly after compression of the sealant layer. As soon as skin formation takes place, a very neat smoothing of the sealant layer is not possible anymore.

Note: the NOFIRNO® sealant is water repellent so that water will drip off. Neat smoothing is helpful in this respect. The NOFIRNO® sealant is also seawater, UV, ozone and weathering resistant and offers a durability of decades.

**INSTALLATION INSTRUCTIONS FOR NOFIRNO®  
MULTI-PIPE TRANSIT SEALING SYSTEM**

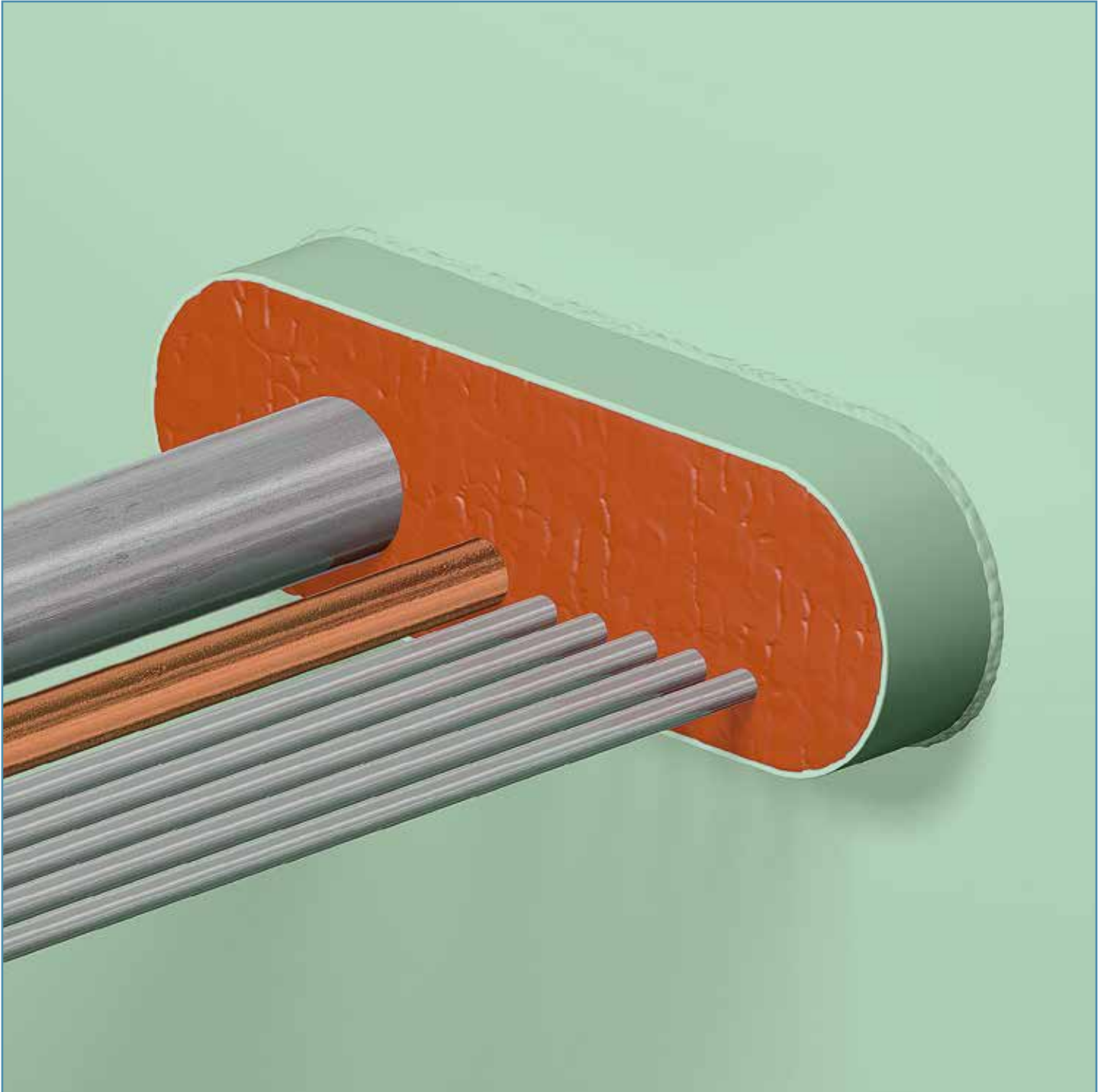

A last check should be made to ensure that the sealant layer is pressed down tightly and that no larger open holes are visible. Air enclosure within the individual layer of sealant should be prevented during finishing, because this would have a negative impact on the performance of the sealant layer under fire exposure.

Please refer to the Safety Data Sheet for more information about the working environment.

## INSTALLATION INSTRUCTIONS FOR NOFIRNO® MULTI-PIPE TRANSIT SEALING SYSTEM



The surface can be smoothed by hand. Just wet the hands thoroughly with water. No dirty hands when working with NOFIRNO® and a very neat surface is the result. Note: this should only be a smoothing procedure. Do not pack or compress the sealant further.

Wear protective gloves when working with NOFIRNO® sealant. Please refer to the Safety Data Sheet for more information.

## **INSTALLATION INSTRUCTIONS FOR NOFIRNO® MULTI-PIPE TRANSIT SEALING SYSTEM**

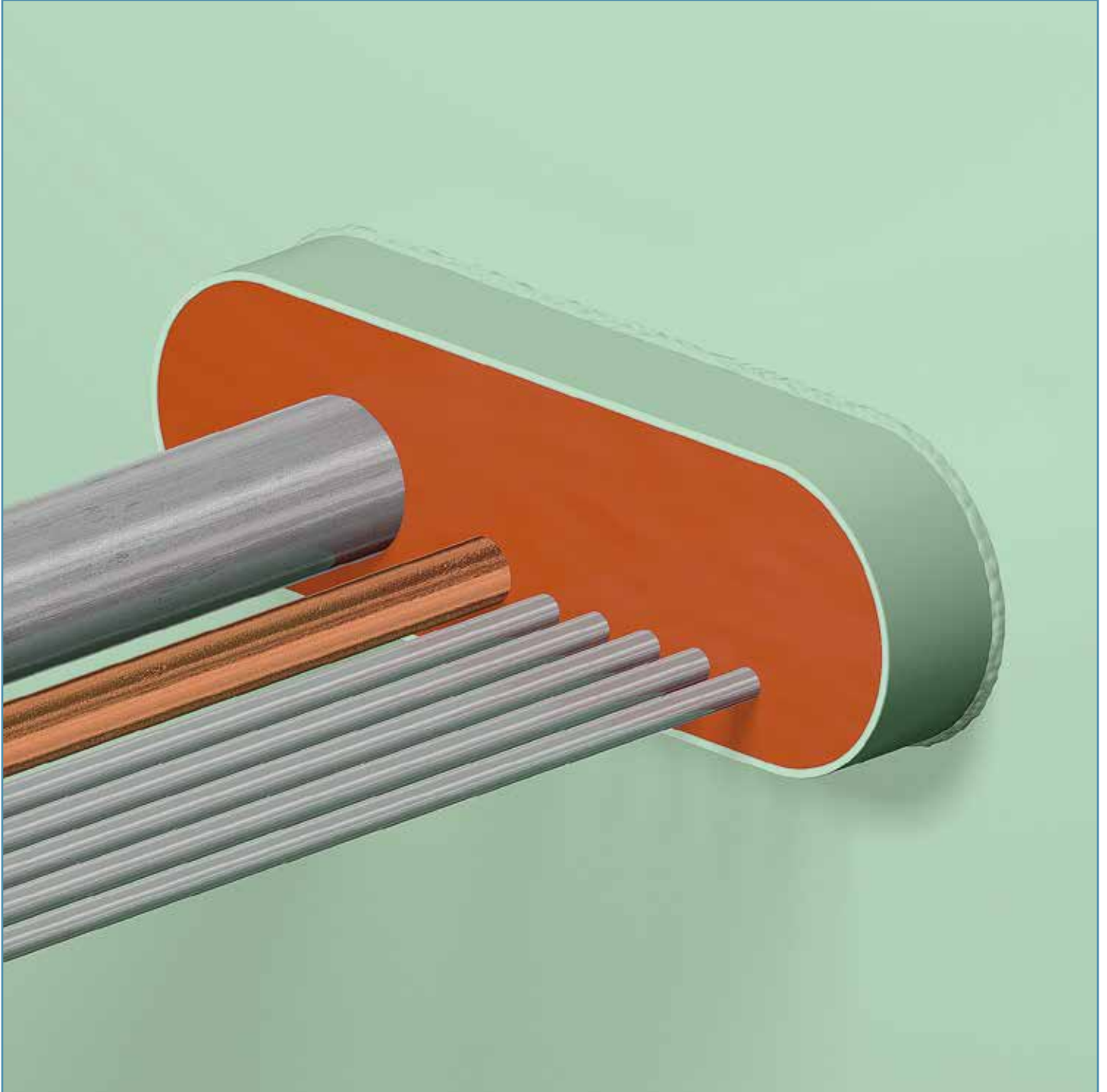

To obtain optimum adhesion during the curing process of the sealant, the pipes should be tightly fixed at both sides of the transit, as close as possible to the transit, and immediately after finishing the transit. Movement of the pipes during the curing process will impair the adhesion process to the surface of the pipe. Note: time needed for curing of the sealant is dependent on air humidity in combination with the environmental temperature. It is advisable to place a sticker near the finished transit, stating that the transit has been recently installed, and should not be touched or damaged.

## INSTALLATION INSTRUCTIONS FOR NOFIRNO® MULTI-PIPE TRANSIT SEALING SYSTEM

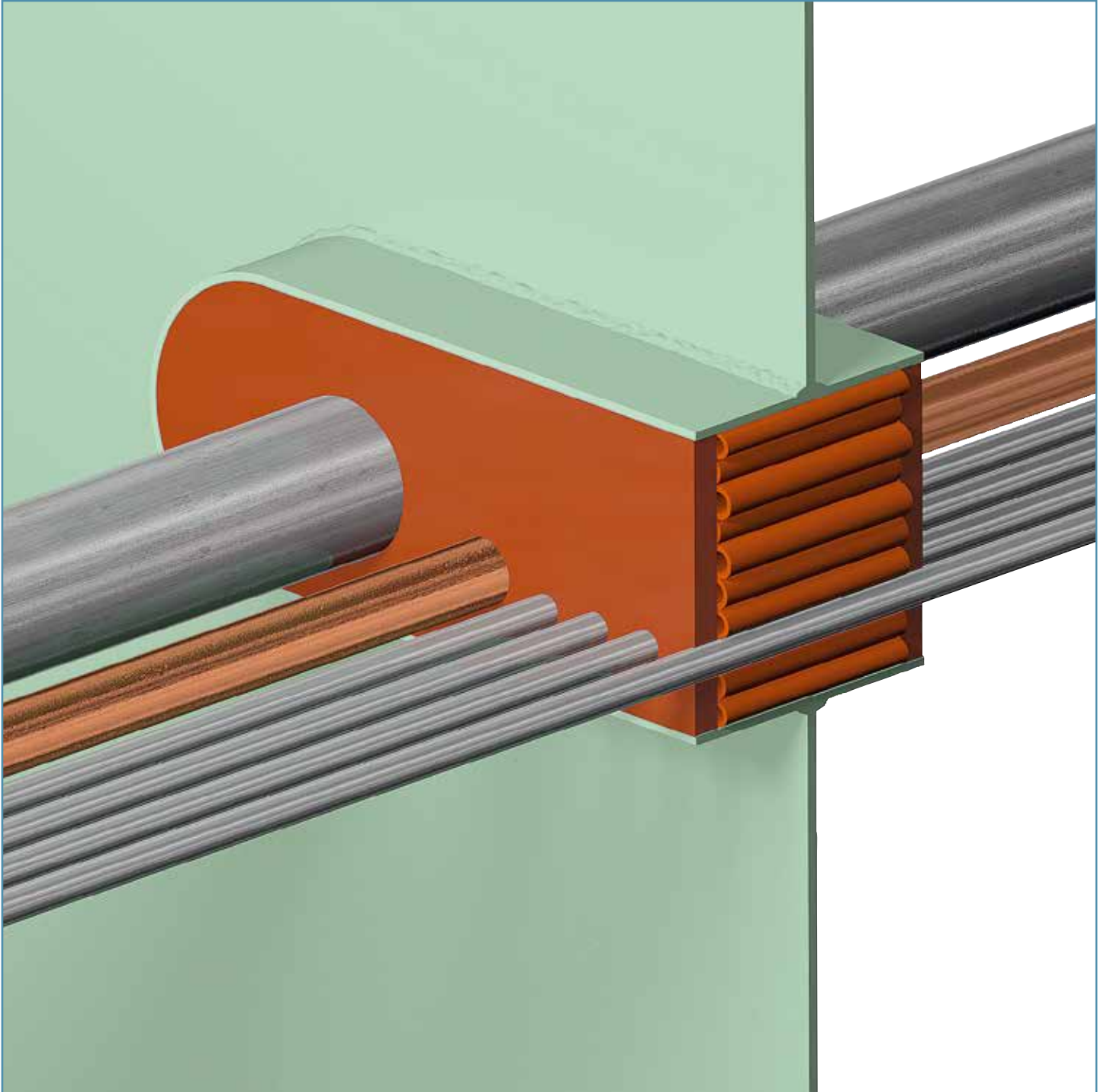

The NOFIRNO rubber grades of the sleeves and the NOFIRNO® sealant, which are compounded under strict conditions in our factory, are suitable for gas and water tight ducting, and for fire rated applications as well. The NOFIRNO® rubber and sealant stay flexible at temperatures of -50 °C, allowing application in arctic environments. The NOFIRNO® system can also be used for steam lines with temperatures up to +180 °C. The NOFIRNO® (multi-) pipe transits have excellent resistance to seawater, UV, ozone and weather. Based on the use of the high tech silicone composition of the NOFIRNO® sealant and rubber, the system offers excellent durability.

## INSTALLATION INSTRUCTIONS FOR NOFIRNO® MULTI-PIPE TRANSIT SEALING SYSTEM

Also certified for multi-mix penetrations  
metallic and plastic pipes and cables.  
Drawing NFN 136E

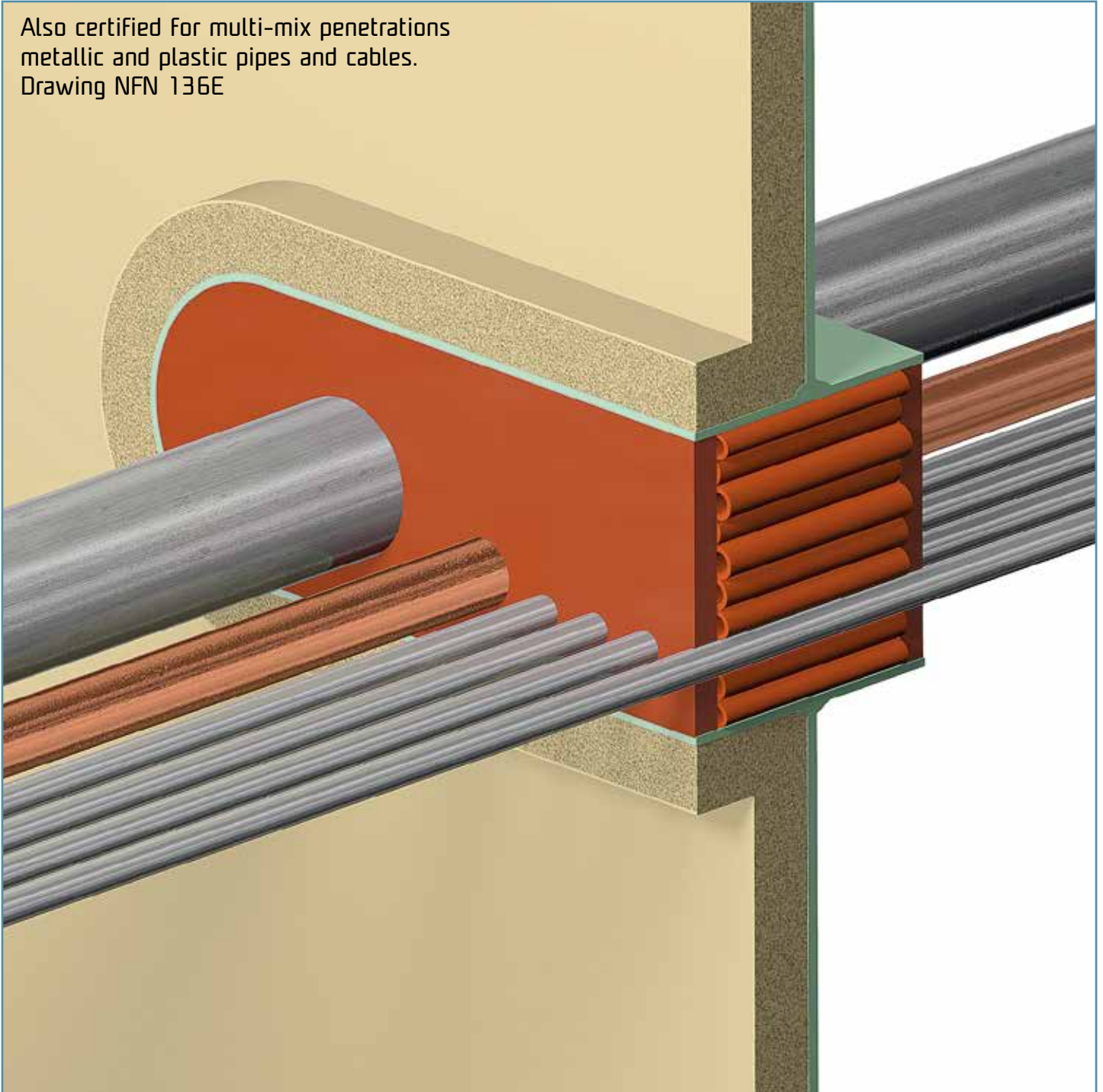

For A-class penetrations (which are insulated), the NOFIRNO® multi-pipe transit frame needs to be insulated only at the insulated side of the bulkhead .  
Check the Type Approval Certificates for the insulation lengths to be applied around the ducted pipes to fulfil the criteria of the maximum temperature rise for A-class penetrations according to the FTP code. MED certificate 192130009AA04 issued by KIWA Netherlands.  
No metal parts are incorporated in the sealing system. The conduit frames cannot corrode inside due to the tight sealant layers at both sides of the transit. No CUI (Corrosion Underneath Insulation).

## INSTALLATION INSTRUCTIONS FOR NOFIRNO® (MULTI-) PIPE TRANSIT SEALING SYSTEM

**direction of exposure:**  
**fire from either side**

Minimum clearance between the conduit sleeve and the ducted pipes and in between the ducted pipes:

|              |       |
|--------------|-------|
| OD pipe      |       |
| up to 3"     | 15 mm |
| ≥3" up to 6" | 20 mm |

**NOFIRNO MULTI-SEALING SYSTEM**  
for steel/ss/CuNi min. 1/16" - max. 6" NPS, GRP pipes min. 1" - max. 6" and copper pipes min. 1/16" - max 4" NPS

**max. size aperture 600x300 mm or equivalent of 1800 cm<sup>2</sup>, min. wall thickness 6 mm**  
Alternative: wall thickness min. 4 mm for transit frames max. 450x170x200 mm or equivalent of 765 cm<sup>2</sup> (20 mm sealant both sides).

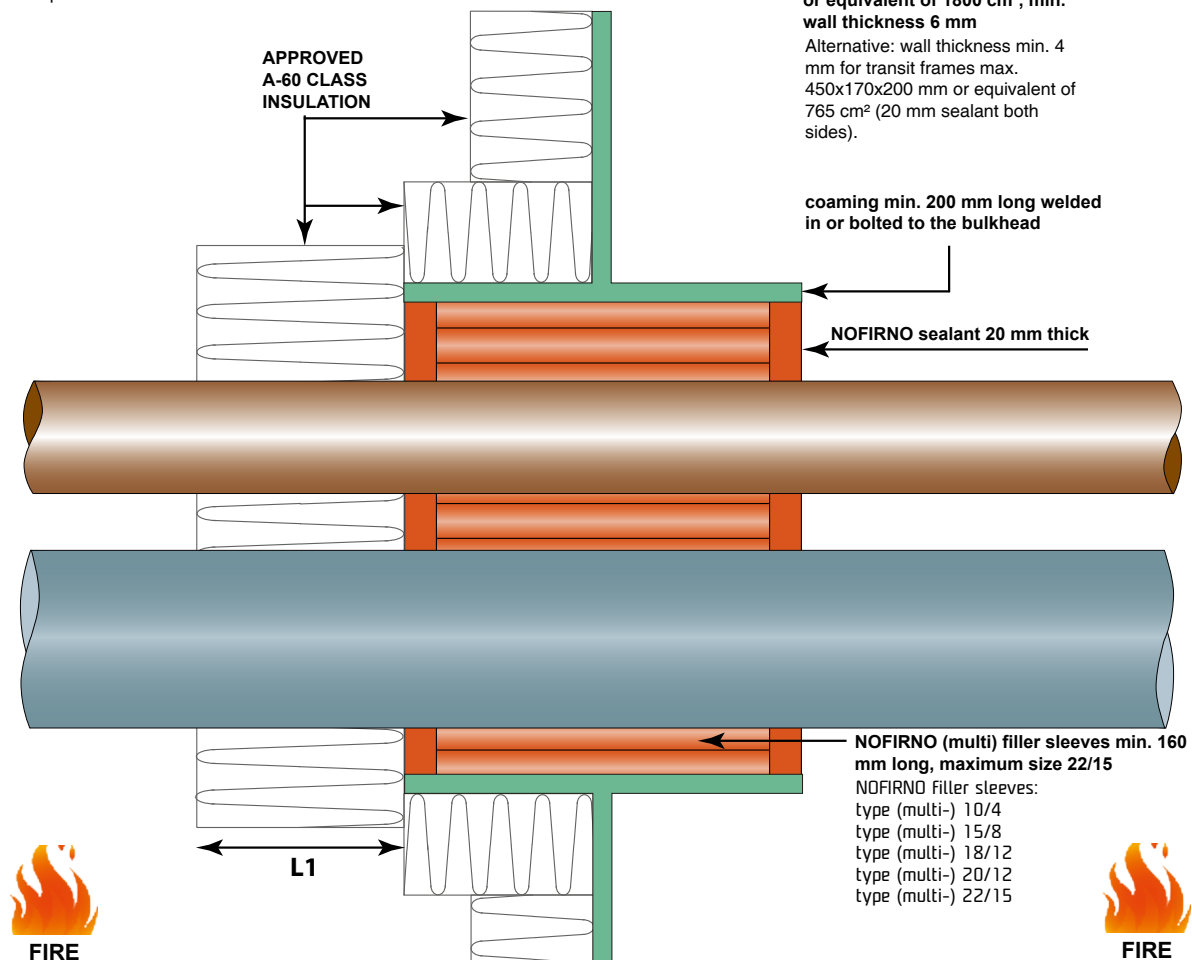

coaming min. 200 mm long welded in or bolted to the bulkhead

NOFIRNO sealant 20 mm thick

NOFIRNO (multi) filler sleeves min. 160 mm long, maximum size 22/15  
NOFIRNO filler sleeves:  
type (multi-) 10/4  
type (multi-) 15/8  
type (multi-) 18/12  
type (multi-) 20/12  
type (multi-) 22/15

L1 = min. length of Insulation around ducted pipe:

|                           |        |              |         |
|---------------------------|--------|--------------|---------|
| steel/ss/CuNi & GRP pipes |        | copper pipes |         |
| up to 1"                  | 200 mm | up to 1"     | 200 mm  |
| ≥1" up to 3"              | 350 mm | ≥1" up to 2" | 500 mm  |
| ≥3" up to 6"              | 500 mm | ≥2" up to 4" | 800 mm  |
|                           |        | 4"           | 1000 mm |

For application in aluminium partitions:  
Aluminium core to be insulated as not to exceed a core temperature of 150 °C.  
For fire from either side insulation to be applied on both sides.  
See paragraph in MED certificate.

**conduit sleeve positioned:**  
**- symmetrical**  
**or**  
**- non-symmetrical with longest length on insulated side**

|   |   |            |                 |  |
|---|---|------------|-----------------|--|
|   | Description: NOFIRNO sealing system for A60 class bulkheads |            |                 |  |
|   | Mat.: NOFIRNO sleeves/sealant                               |            |                 |  |
| Ref.: JAB   | Date:   | 14-10-2019 | Scale:          |  |
| <i>No part of this document may be reproduced by photocopy, print, microfilm or any means without the written permission of BEELE Engineering bv of The Netherlands</i> | Rev. 1  | 05-03-2020 | <b>NFN 134E</b> |  |
|   | Rev. 2  | 02-04-2020 |                 |  |

## INSTALLATION INSTRUCTIONS FOR NOFIRNO® (MULTI-MIX) PIPE/CABLE TRANSIT SEALING SYSTEM

**direction of exposure:  
fire from either side**

Minimum clearance between  
conduit sleeve and ducted metallic pipe:

|              |       |
|--------------|-------|
| OD pipe      |       |
| up to 3"     | 15 mm |
| ≥3" up to 6" | 20 mm |

**CRUSHER** plugs or wraps:  
minimum 160 mm long,  
thickness min. 2 mm for pipes up to 25 mm.  
thickness min. 4 mm for pipes 26-50 mm  
thickness min. 6 mm for pipes 51-74 mm  
thickness min. 8 mm for pipes 75-109 mm  
thickness min. 14 mm for pipes 110-124 mm  
thickness min. 18 mm for pipes 125-139 mm  
thickness min. 20 mm for pipes 140-160 mm

**CRUSHER** plugs/wraps around plastic  
pipes; **RISE** sleeves for cables

**NOFIRNO MULTI-MIX SEALING SYSTEM**  
for steel/ss/CuNi min. 1/16" - max. 6" NPS,  
copper pipes min. 1/16" - max 4" NPS, GRP  
pipes min. 1" - max. 6", plastic pipes max.  
**160 mm and cables max. 105 mm**

max. size aperture 1000x300 mm  
or equivalent of 3000 cm<sup>2</sup>, min.  
wall thickness 6 mm

Alternative: wall thickness min. 4  
mm for transit frames max.  
450x170x200 mm or equivalent of  
765 cm<sup>2</sup> (20 mm sealant both  
sides).

**coaming min. 200 mm long welded  
in or bolted to the bulkhead**

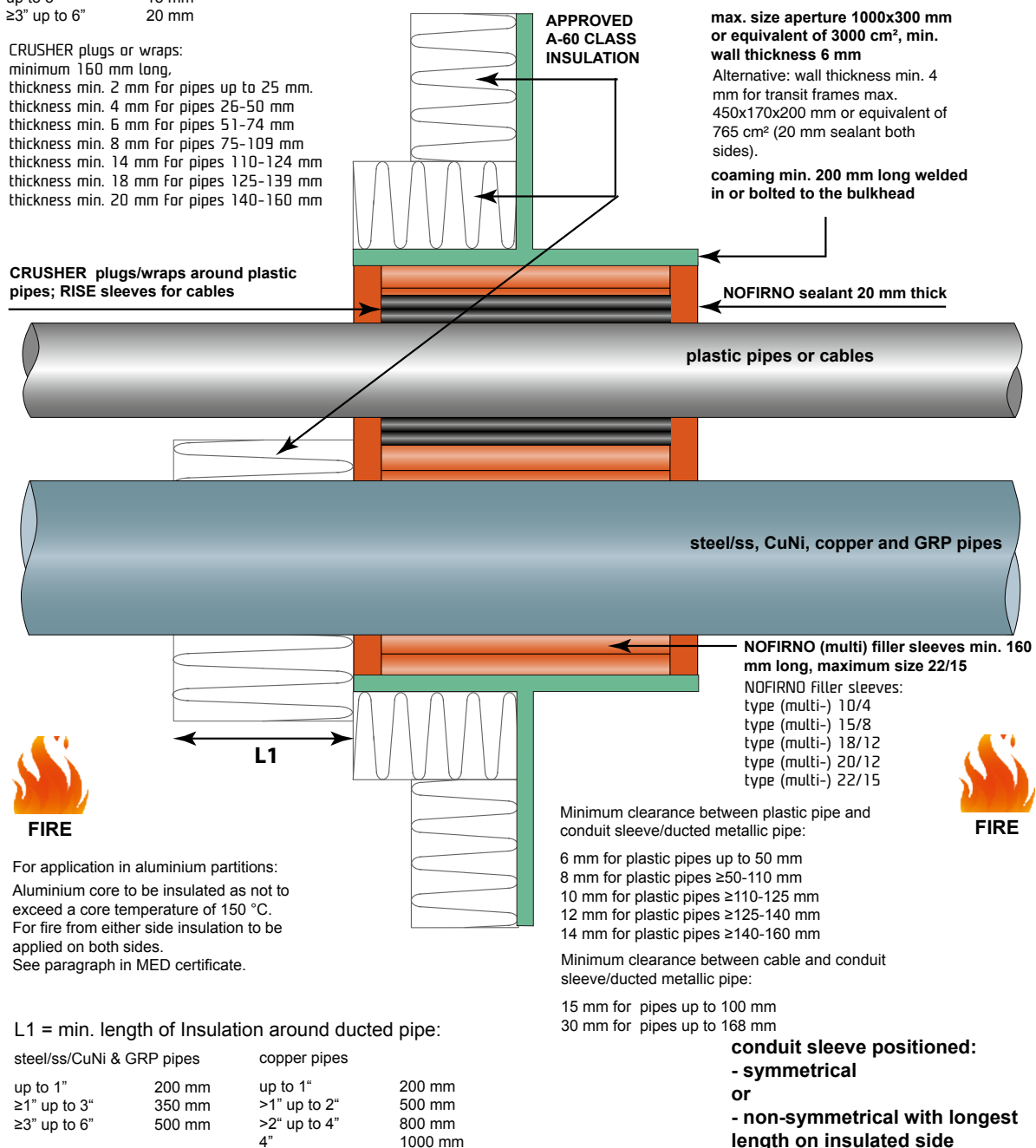

For application in aluminium partitions:  
Aluminium core to be insulated as not to  
exceed a core temperature of 150 °C.  
For fire from either side insulation to be  
applied on both sides.  
See paragraph in MED certificate.

|   |   |            |                 |  |
|---|---|------------|-----------------|--|
|   | Description: NOFIRNO sealing system for A60 class bulkheads |            |                 |  |
|   | Mat.: NOFIRNO sleeves/sealant                               |            |                 |  |
| Ref.: JAB   | Date:   | 14-10-2019 | Scale:          |  |
| <i>No part of this document may be reproduced by photocopy,<br/>print, microfilm or any means without the written permission<br/>of BEELE Engineering bv of The Netherlands</i> | Rev. 2  | 02-04-2020 | <b>NFN 136E</b> |  |
|   | Rev. 3  | 09-10-2020 |                 |  |

**INSTALLATION INSTRUCTIONS FOR NOFIRNO®  
MULTI-PIPE TRANSIT SEALING SYSTEM**

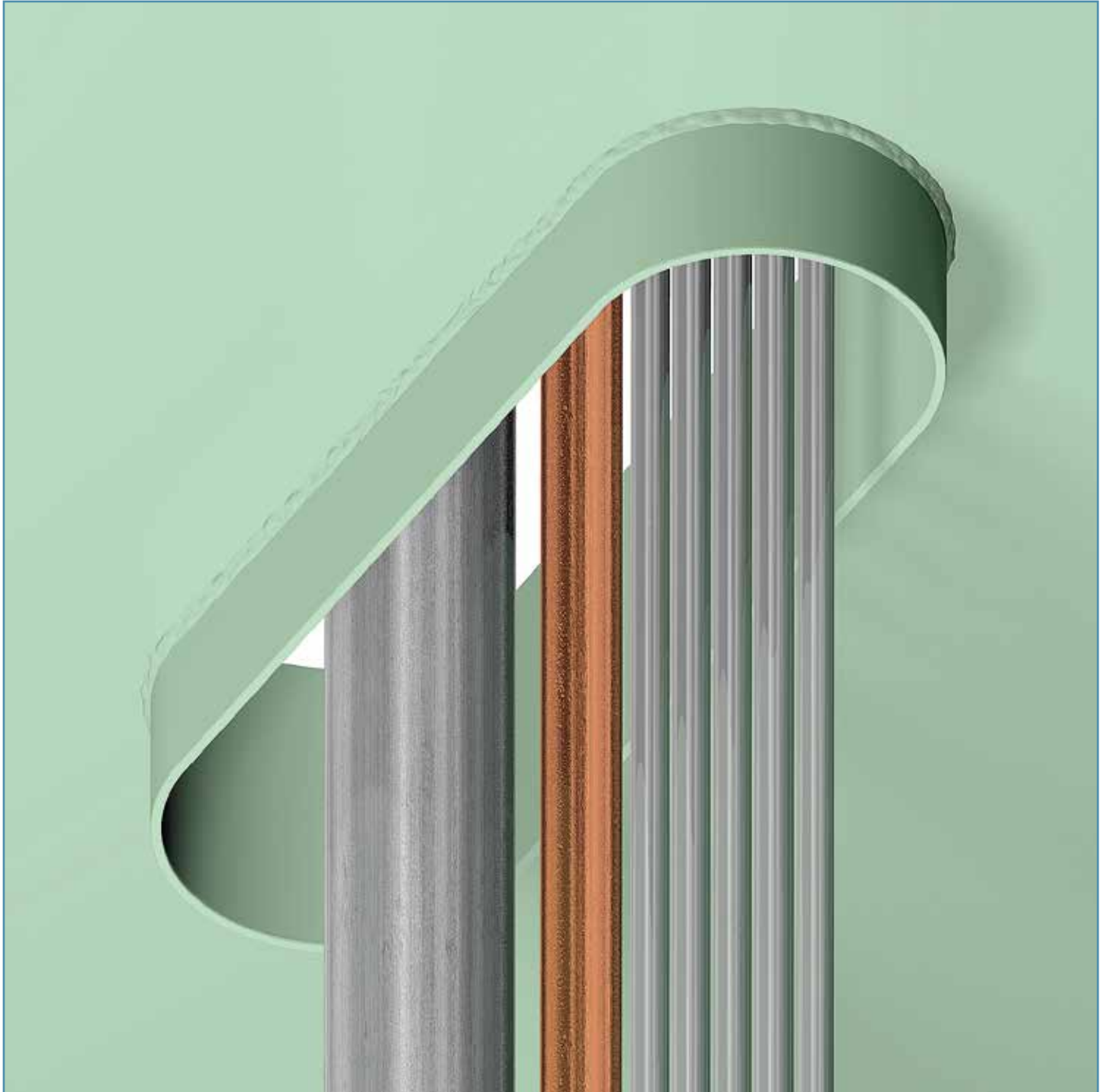

Deck penetrations are also easy to install with the NOFIRNO® system.

**INSTALLATION INSTRUCTIONS FOR NOFIRNO®  
MULTI-PIPE TRANSIT SEALING SYSTEM**

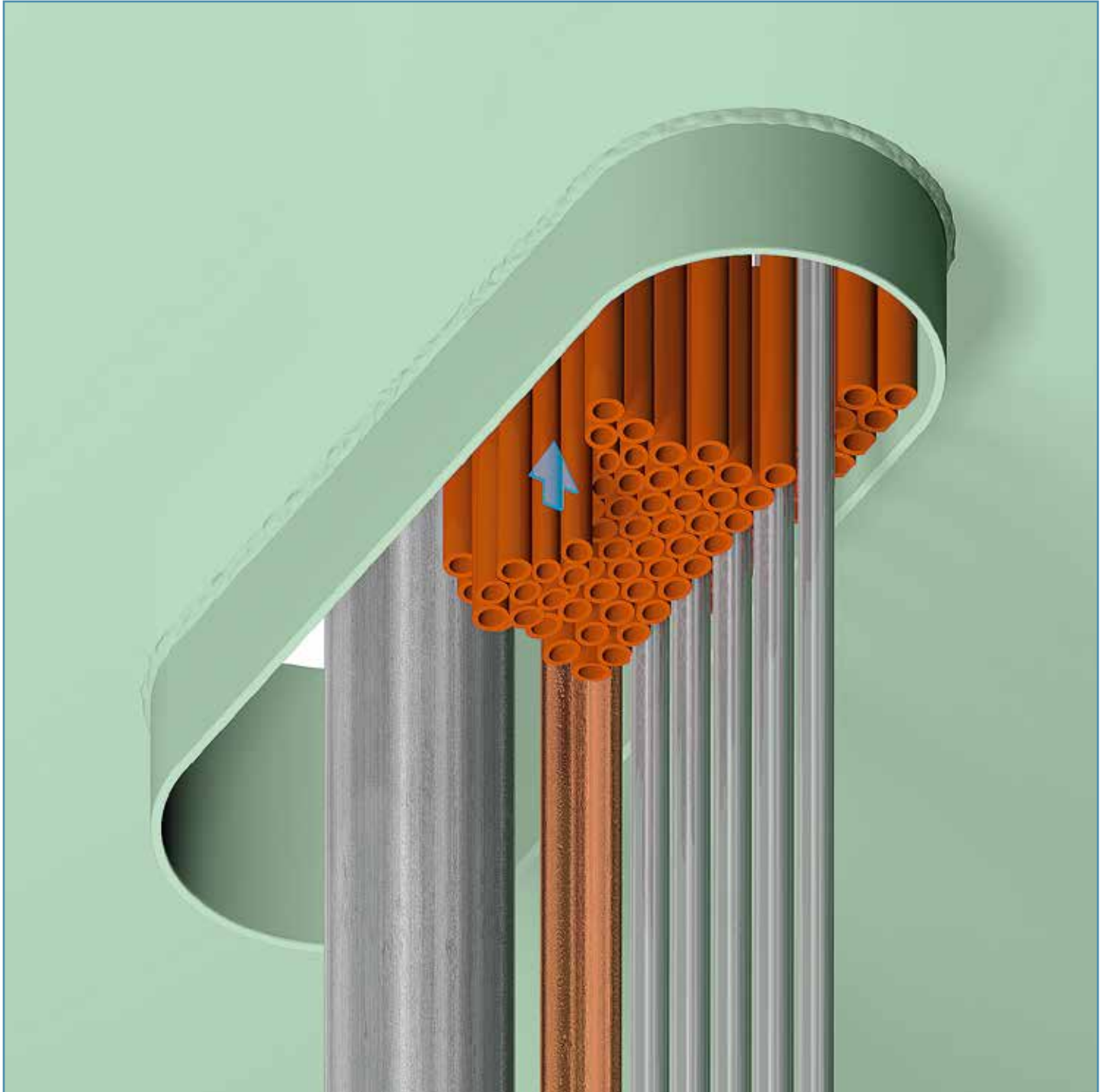

The multi-filler sleeves are very useful, especially for sealing deck penetrations. By making use of the NOFIRNO® multi-filler sleeves, sets and bundles can be made to ensure tight fitting inside the transit. Inserting fitting sets or bundles of multi-sleeves will ensure that sleeves won't fall out of the conduit frame. With NOFIRNO® single filler sleeves, the filling of larger vertical transits will be more difficult.

**INSTALLATION INSTRUCTIONS FOR NOFIRNO®  
MULTI-PIPE TRANSIT SEALING SYSTEM**

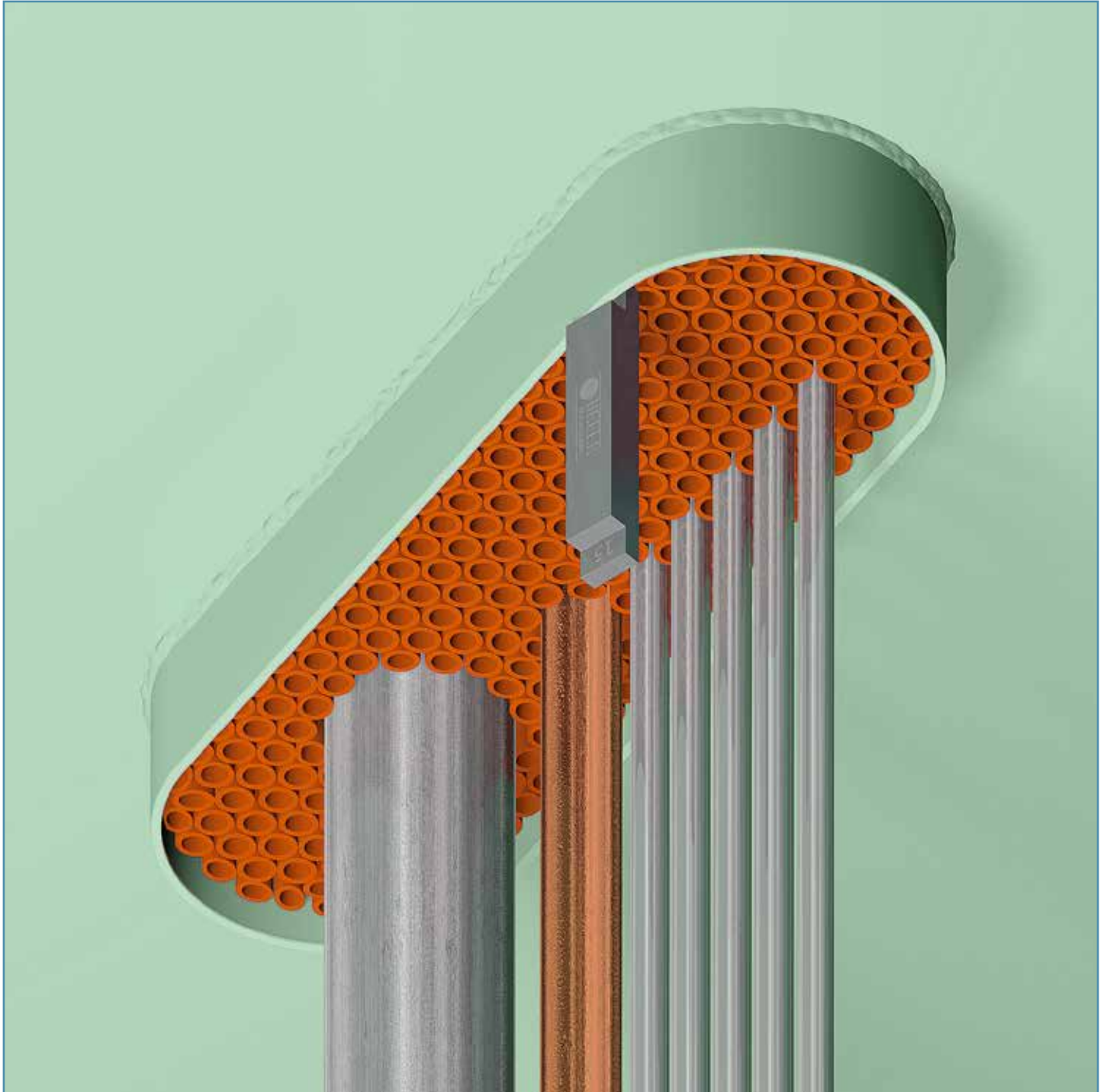

With the Beele® adjuster or a marked piece of wood, the set of fillers is adjusted inside the transit. The NOFIRNO® rubber grade and the NOFIRNO® sealant, which are compounded under strict conditions in our factory, are suitable for gas and water tight ducting, and for highest fire rated applications as well.

**INSTALLATION INSTRUCTIONS FOR NOFIRNO®  
MULTI-PIPE TRANSIT SEALING SYSTEM**

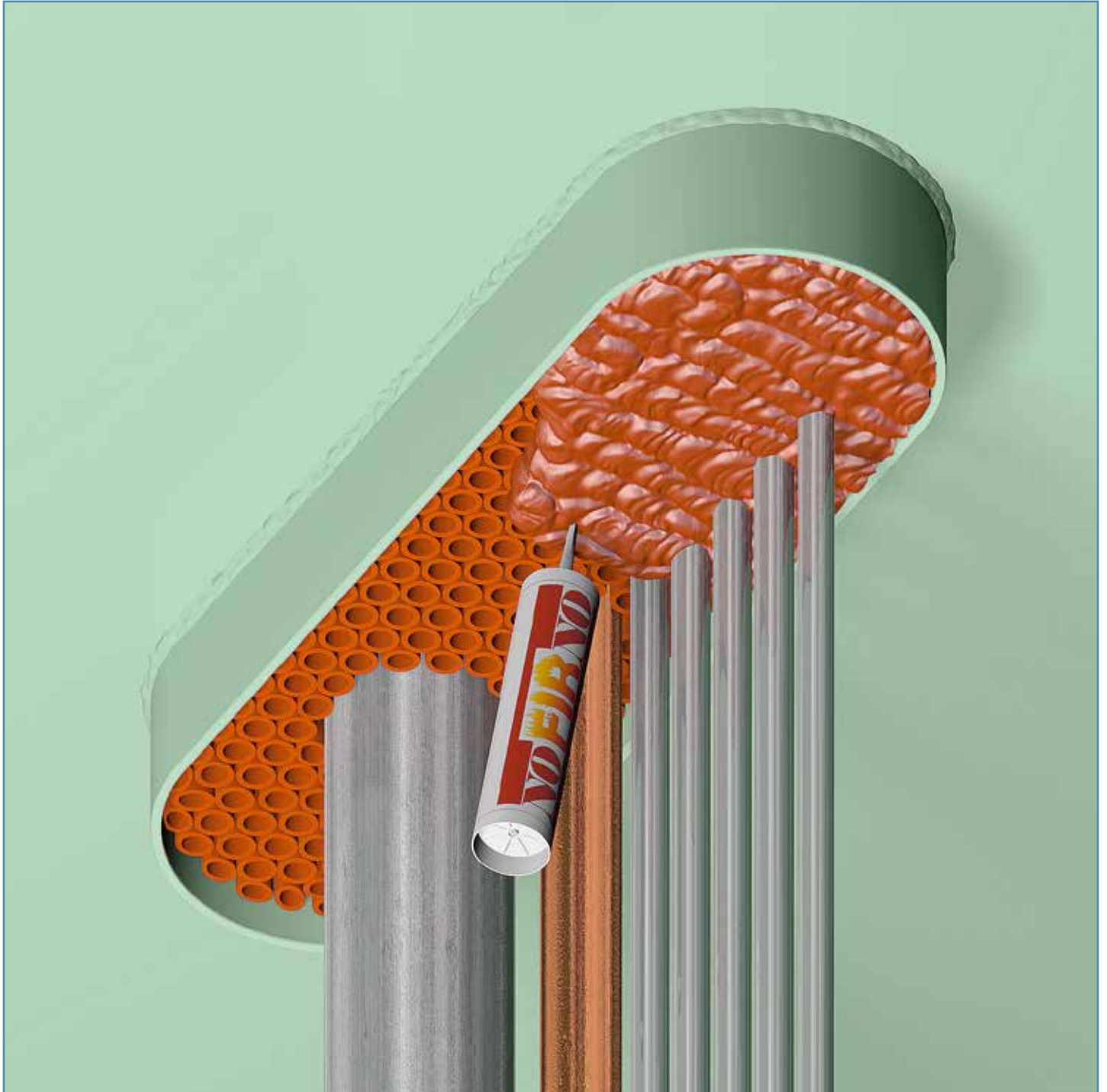

The NOFIRNO® sealant can be applied overhead for deck/floor transits without dripping or sagging. After application of the sealant, the NOFIRNO® sealant is pressed tightly with a cloth sprayed with water. This prevents the sealant from sticking to the cloth.

Please refer to the Safety Data Sheet for more information about the working environment.

**INSTALLATION INSTRUCTIONS FOR NOFIRNO®  
MULTI-PIPE TRANSIT SEALING SYSTEM**

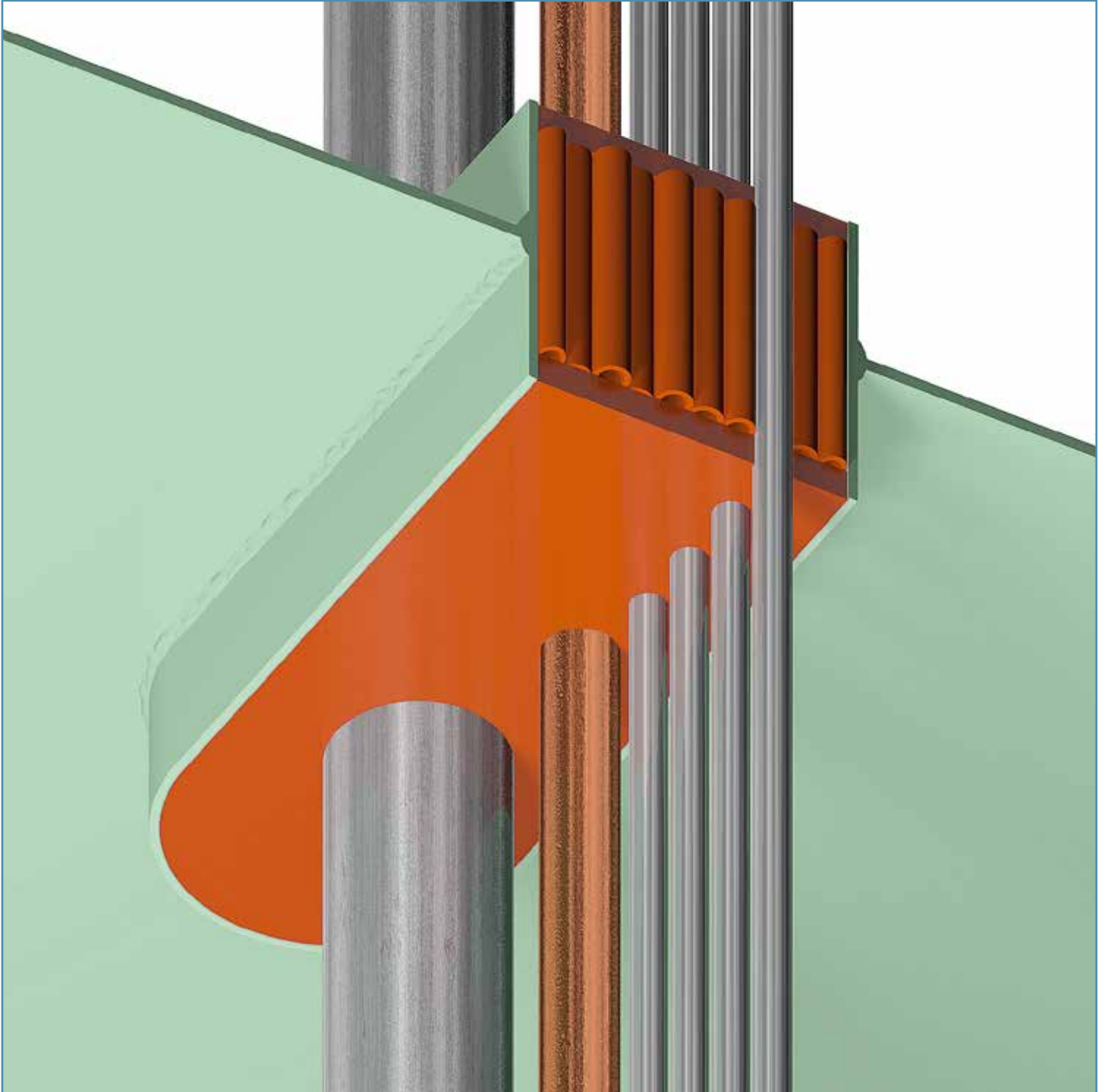

The surface can be smoothed by hand. Just wet the hands thoroughly with water. No dirty hands when working with NOFIRNO® and a very neat surface is the result. Note: this should only be a smoothing procedure. Do not pack or compress the sealant further.

Wear protective gloves when working with NOFIRNO® sealant. Please refer to the Safety Data Sheet for more information.

## INSTALLATION INSTRUCTIONS FOR NOFIRNO® MULTI-PIPE TRANSIT SEALING SYSTEM

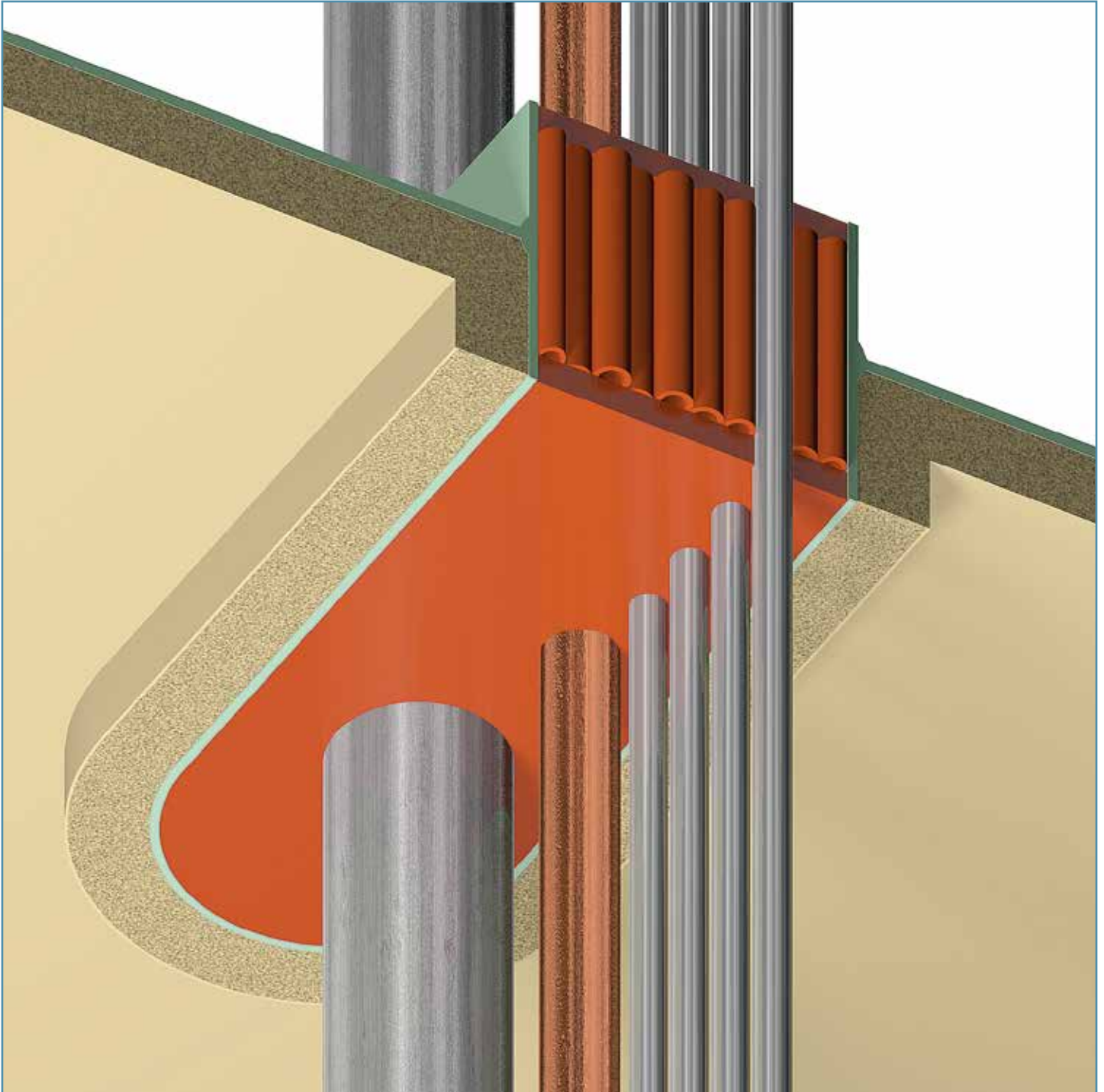

For A-class penetrations (which are insulated), the NOFIRNO® multi-pipe transit frame needs to be insulated only at the insulated side of the deck.  
Check the Type Approval Certificates for the insulation lengths to be applied around the ducted pipes to fulfil the criteria of the maximum temperature rise for A-class penetrations according to the FTP code. MED certificate 192130009AA04 issued by KIWA Netherlands.  
No metal parts are incorporated in the sealing system. The conduit frames cannot corrode inside due to the tight sealant layers at both sides of the transit. No CUI (Corrosion Underneath Insulation).

## INSTALLATION INSTRUCTIONS FOR NOFIRNO® (MULTI-) PIPE TRANSIT SEALING SYSTEM

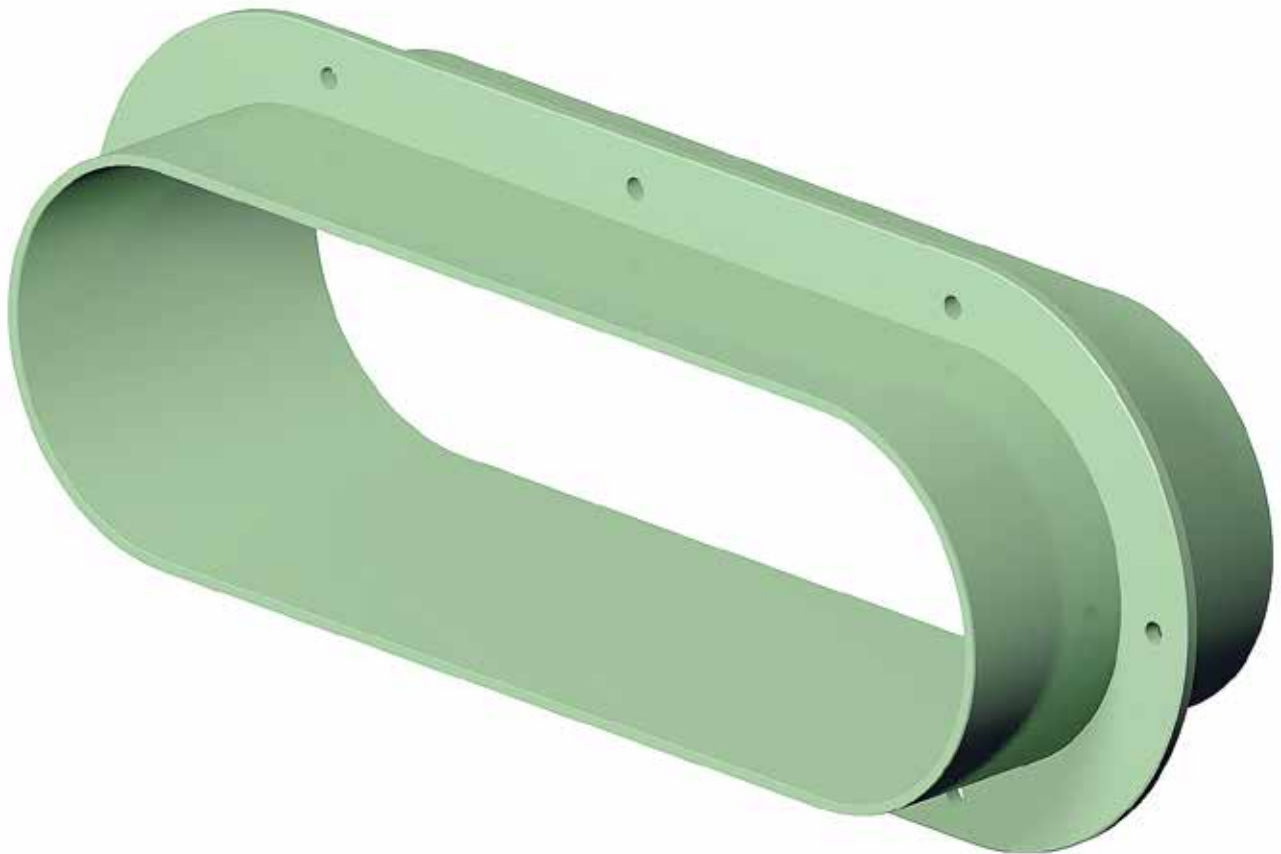

Flanged frames with a flange for bolting (60 mm wide and 6 mm thick) with a hole configuration for fixation, can be used also for the NOFIRNO® multi-pipe sealing system.

## INSTALLATION INSTRUCTIONS FOR NOFIRNO® (MULTI-) PIPE TRANSIT SEALING SYSTEM

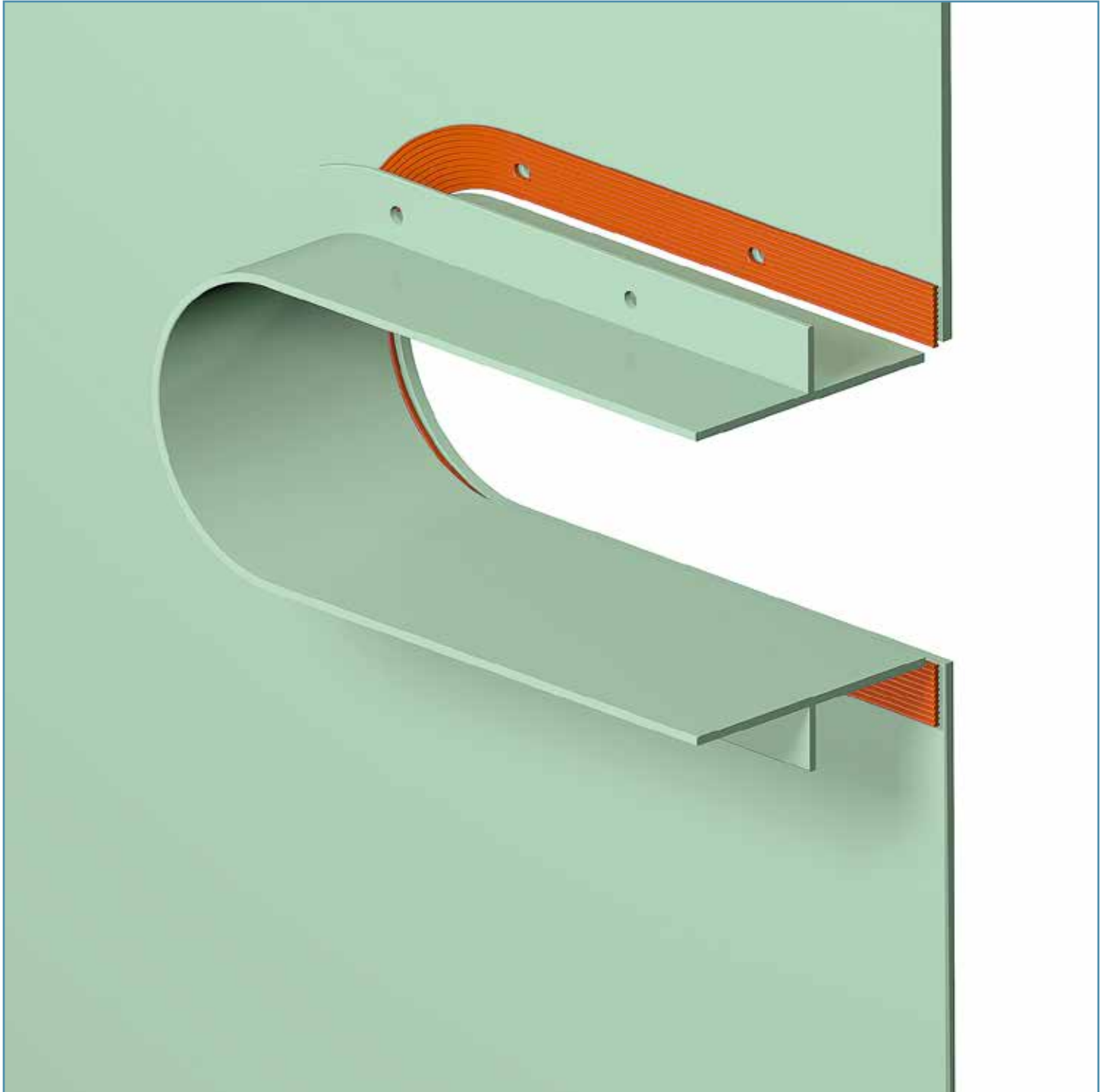

The flanged transit frames are bolted against the partition. A firesafe NOFIRNO® gasket has to be applied between the flange of the transit frame and the partition. The gaskets have a designed profiling to exclude the need for excessive compression (6-10 Nm is sufficient). The reduced forces on the profiled rubber make the usual need for retightening from time to time a thing of the past.

## INSTALLATION INSTRUCTIONS FOR NOFIRNO® (MULTI-) PIPE TRANSIT SEALING SYSTEM

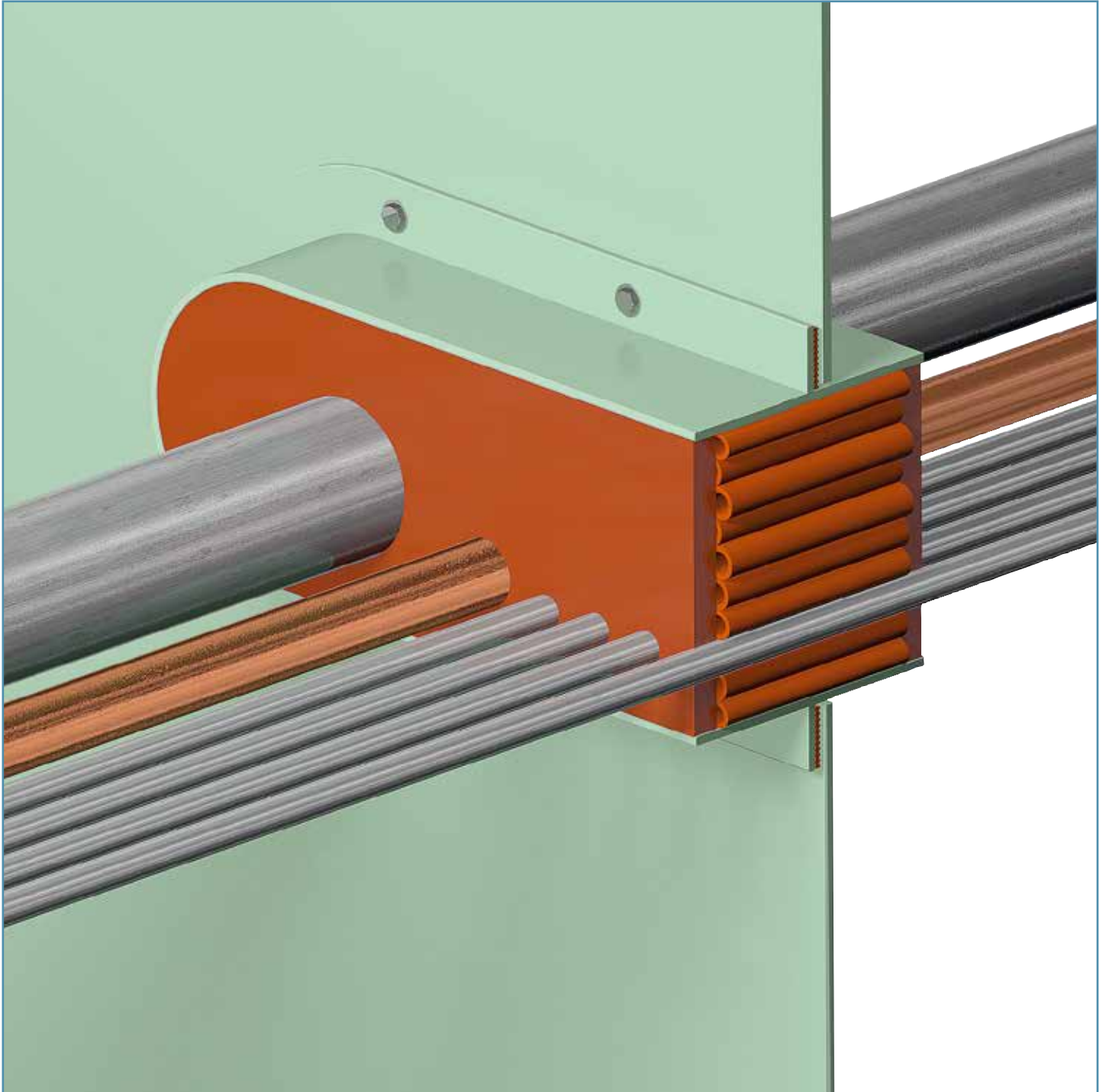

For A-class penetrations (which are insulated), the NOFIRNO® (multi-) pipe transit Frame needs to be insulated only at the insulated side of the bulkhead or at the lower side of the deck. Check the Type Approval Certificates for the insulation lengths to be applied around the ducted pipes to fulfil the criteria of the maximum temperature rise for A-class penetrations according to the FTP code.

## INSTALLATION INSTRUCTIONS FOR NOFIRNO® (MULTI-) PIPE TRANSIT SEALING SYSTEM

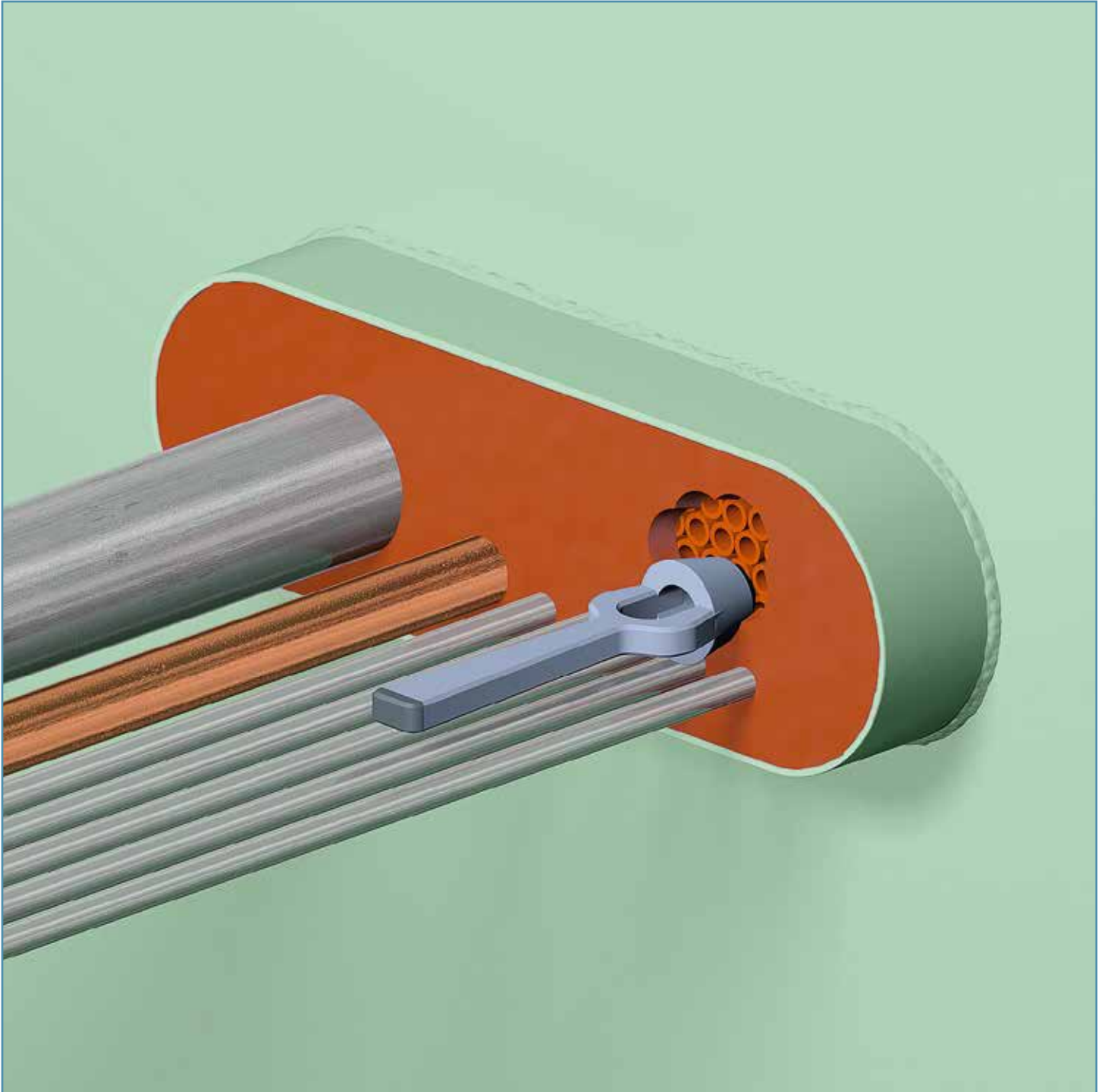

Adding an extra pipe through a finished NOFIRNO® multi-pipe transit is an easy job. With the use of NOFIRNO® filler sleeves as separators, no permanent deformation of the rubber parts will occur, and the pipes are ducted individually. This means there is no need to disassemble the whole transit. Cut away the sealant layer at both sides of the penetration with a plastic knife or a hollow punch in a tapering shape, at a spot where there is sufficient spare space visible on the surface of the sealant layer.

**INSTALLATION INSTRUCTIONS FOR NOFIRNO®  
(MULTI-) PIPE TRANSIT SEALING SYSTEM**

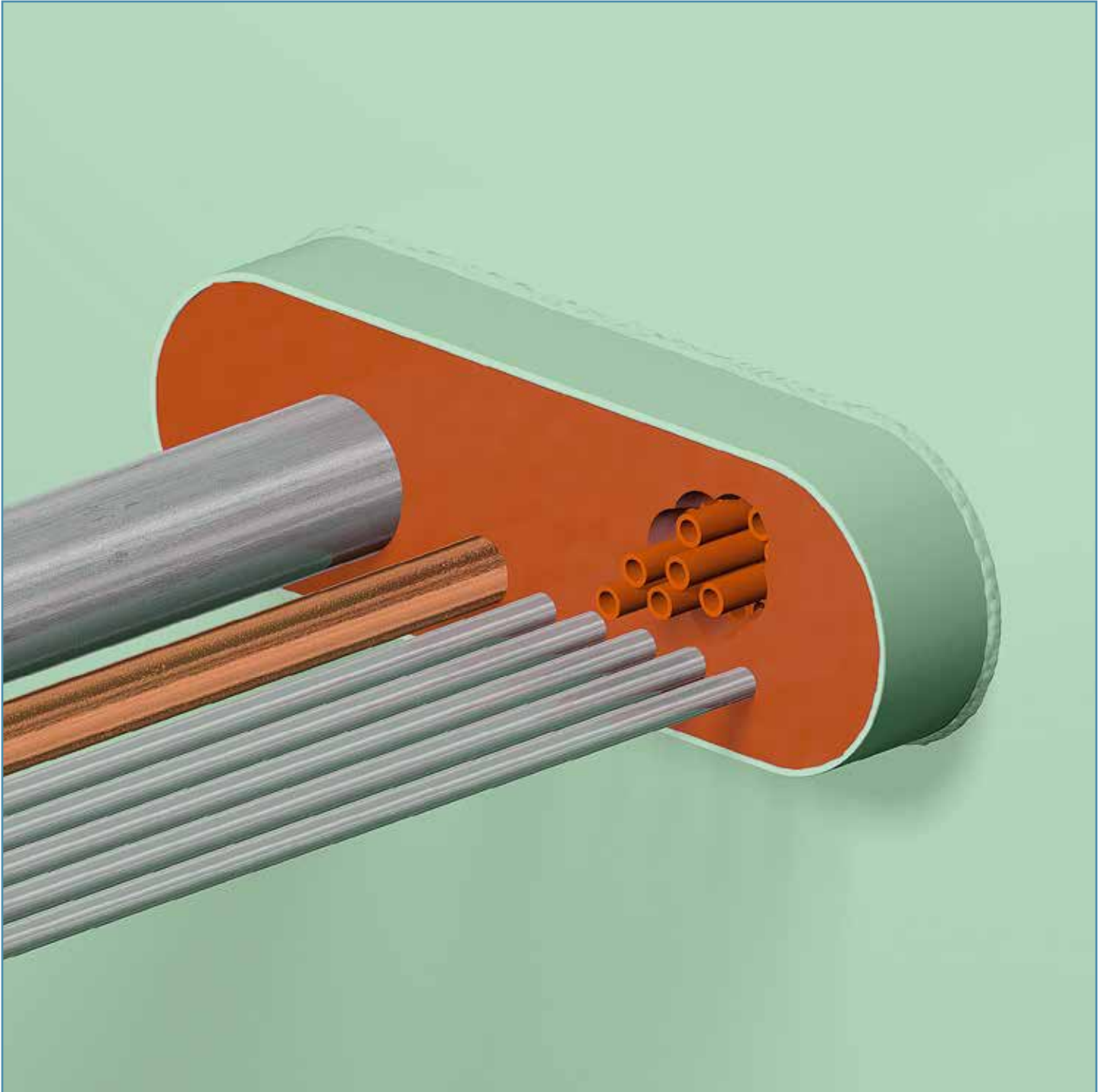

Remove enough NOFIRNO® filler sleeves to create an appropriate opening for the pipe to be ducted.

**INSTALLATION INSTRUCTIONS FOR NOFIRNO®  
(MULTI-) PIPE TRANSIT SEALING SYSTEM**

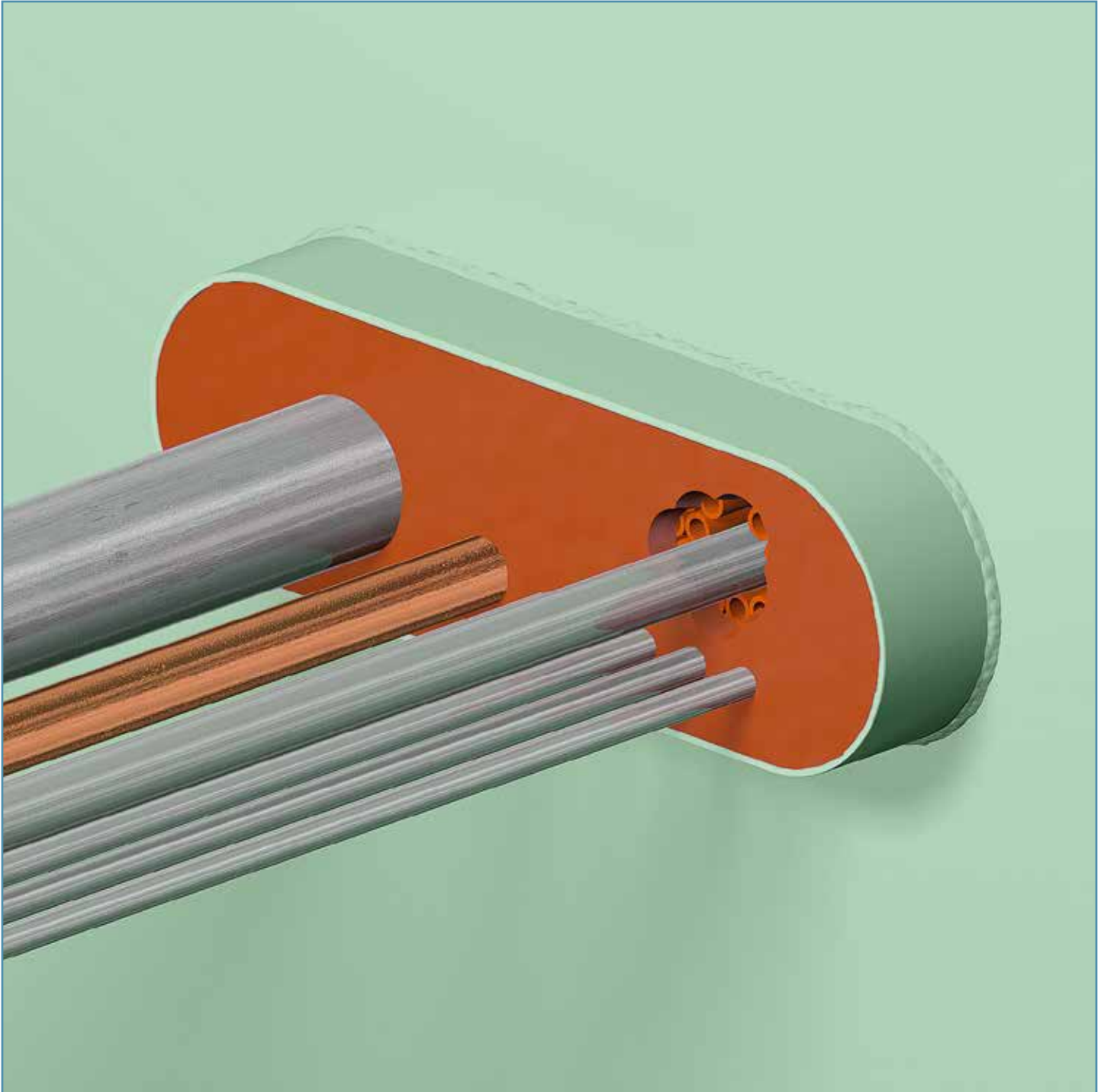

A pipe is ducted through the free passage opening in the NOFIRNO® multi-pipe transit. For adding a pipe, there is in fact no more disassembling needed than removing some filler sleeves. No extra costs for the extension of the pipe set other than some new sealant to be applied.

**INSTALLATION INSTRUCTIONS FOR NOFIRNO®  
(MULTI-) PIPE TRANSIT SEALING SYSTEM**

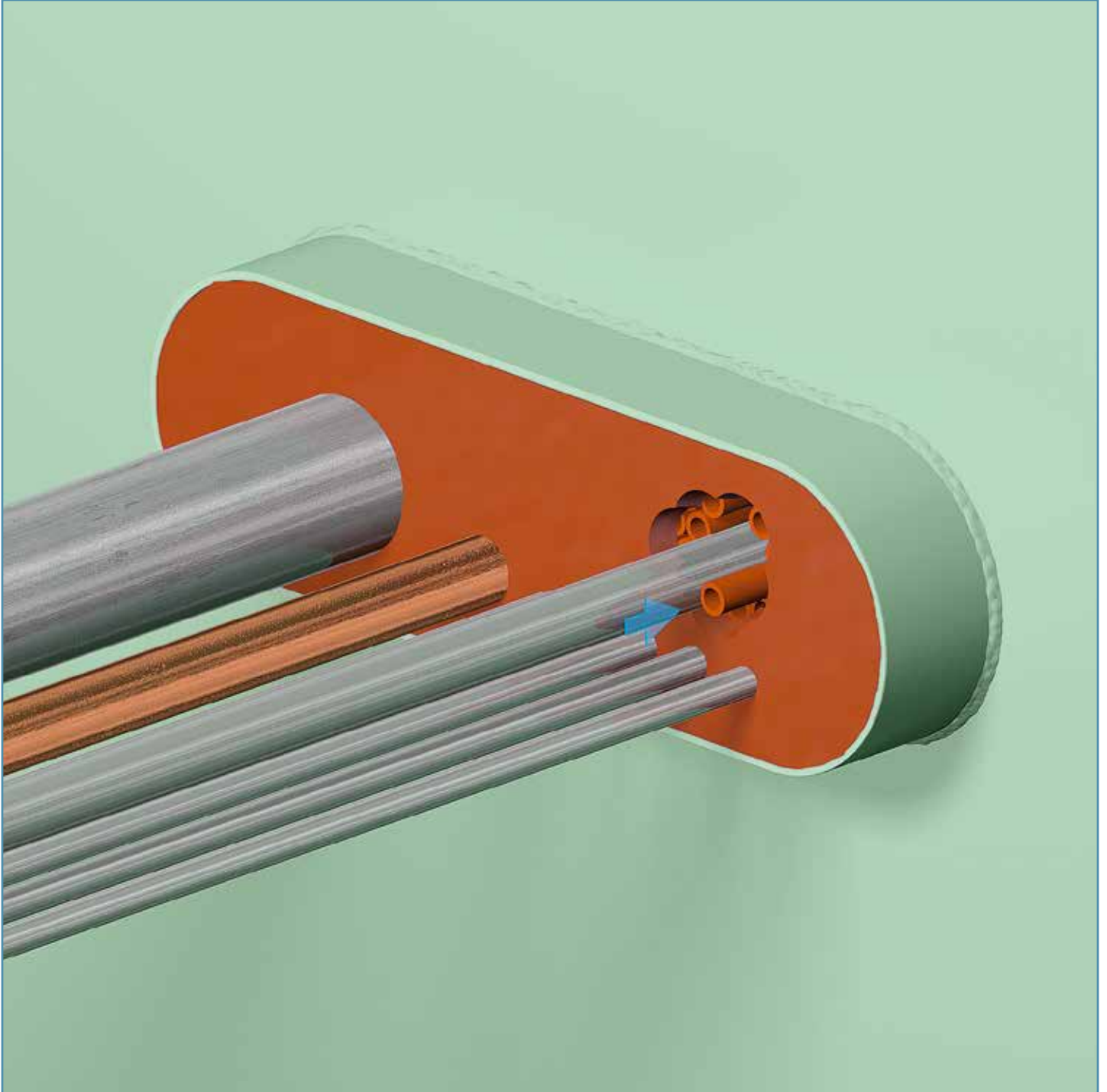

Refill the open spaces around the ducted pipe with NOFIRNO® Filler sleeves. Ensure a tight fit of the Filler sleeves around the ducted pipe to obtain mechanical stability of the sealing system, and to prevent the ducted pipe from movement inside the pipe transit.

**INSTALLATION INSTRUCTIONS FOR NOFIRNO®  
(MULTI-) PIPE TRANSIT SEALING SYSTEM**



Clean and dry the newly ducted pipe thoroughly and refill the opening in the sealant layer at both sides of the transit with NOFIRNO® sealant. The fresh sealant adheres very well to the already cured sealant. Finish the new sealant layer in the same way as done for the initial sealant layer.

Please refer to the Safety Data Sheet for more information about the working environment.

**INSTALLATION INSTRUCTIONS FOR NOFIRNO®  
(MULTI-) PIPE TRANSIT SEALING SYSTEM**

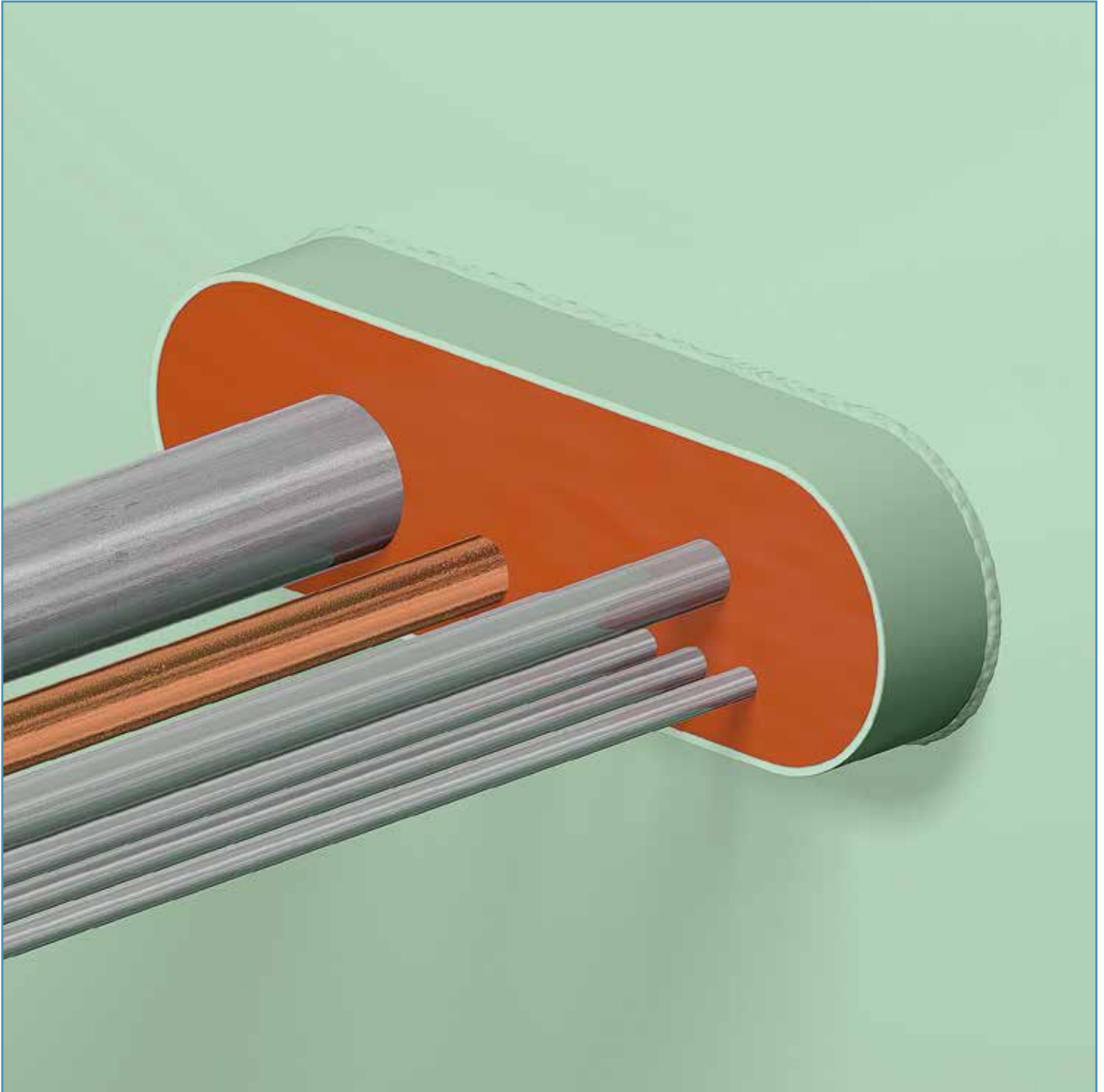

Note: time needed for curing of the sealant is dependent on air humidity in combination with the environmental temperature.

## INSTALLATION INSTRUCTIONS FOR NOFIRNO® BLIND TRANSIT SEALING SYSTEM

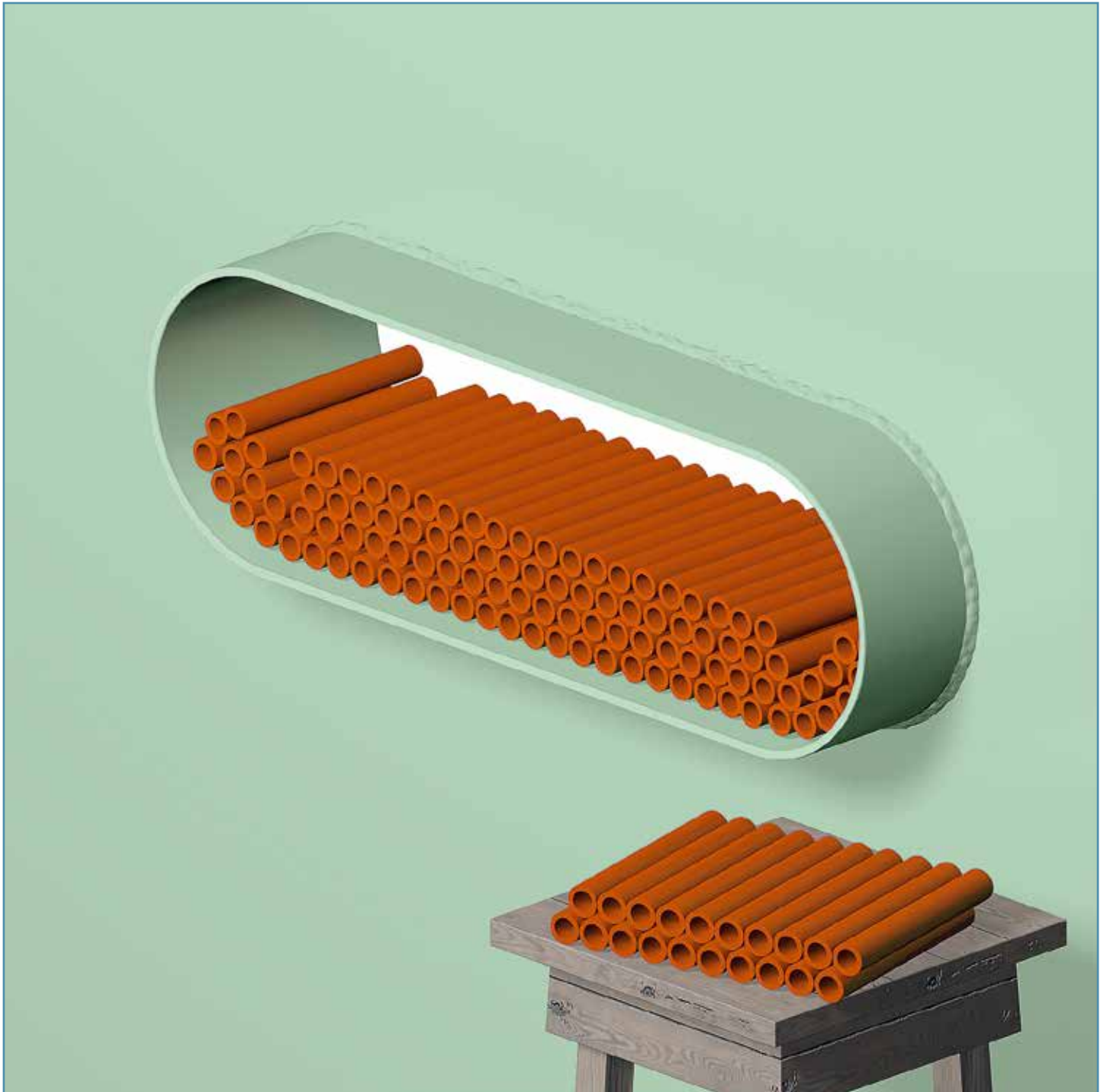

The NOFIRNO® system has been tested also for blind penetrations.

The space inside the transit frame is filled with NOFIRNO® filler sleeves type 22/15. For ease of filling, the NOFIRNO® filler sleeves are supplied non-split. Multi-filler sleeves (set of 10) are preferred for filling larger spaces.

Filling the conduit frame with NOFIRNO® multi-filler sleeves starts with stacking the multi-set on top of each other and to place rolled-up sets of multi-sleeves in the corners.

## INSTALLATION INSTRUCTIONS FOR NOFIRNO® BLIND TRANSIT SEALING SYSTEM

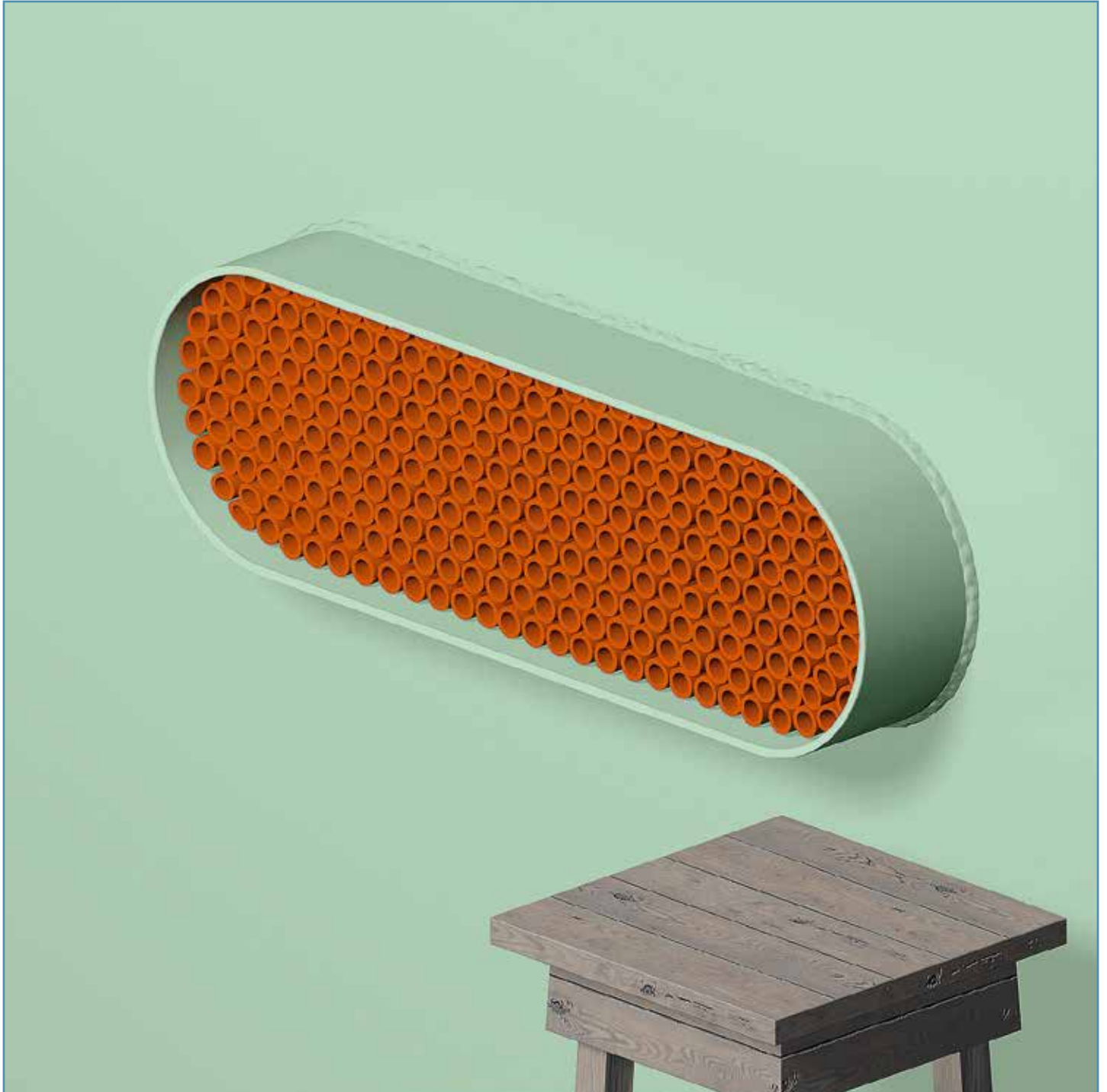

Before applying the NOFIRNO® sealant, it is advisable to perform a final check on the packing of the filler sleeves. A tight fit of the whole set of sleeves in the required ratio is not only vital for the mechanical stability of the sealing system, but also for the fire stopping properties. A final check should therefore be a part of quality control.

## **INSTALLATION INSTRUCTIONS FOR NOFIRNO® BLIND TRANSIT SEALING SYSTEM**



The NOFIRNO rubber grade of the sleeves and the NOFIRNO® sealant, which are compounded under strict conditions in our factory, are suitable for gas and water tight ducting, and for fire rated applications as well. The NOFIRNO® sealant stays flexible at temperatures of -50 °C, allowing application in arctic environments.

The NOFIRNO® blind transits have excellent resistance to seawater, UV, ozone and weather. Based on the use of the high tech silicone composition of the NOFIRNO® sealant and rubber, the system offers excellent durability.

**INSTALLATION INSTRUCTIONS FOR NOFIRNO®  
BLIND TRANSIT SEALING SYSTEM**

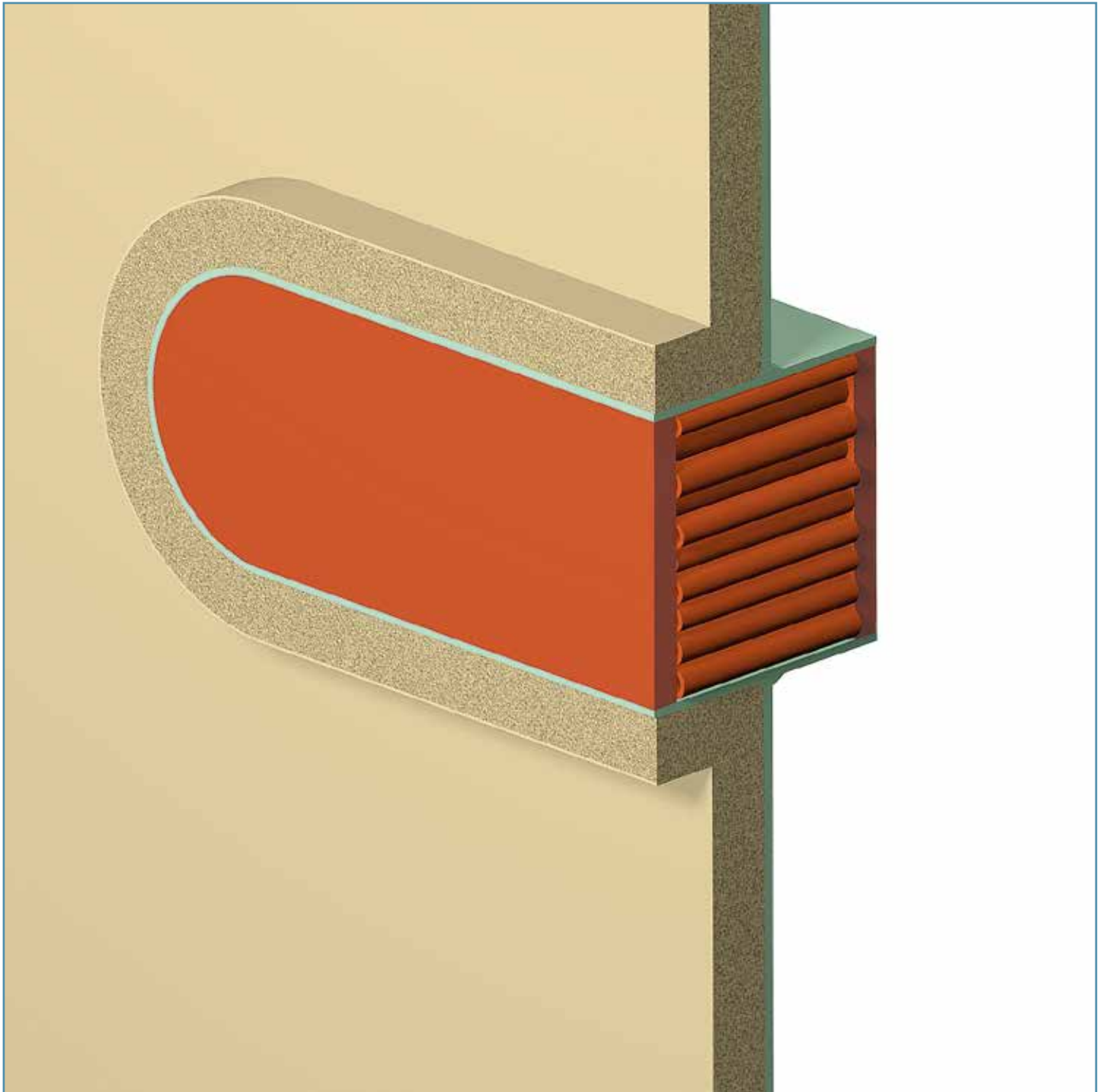

For A-class penetrations (which are insulated), the NOFIRNO® blind transit frame needs to be insulated only at the insulated side of the bulkhead or the lower side of the deck. No extra insulation needed in front of the transit. Max. size of the coaming 600x300 mm.

For transits larger than 300x150 mm partitions have to be provided dividing the transit in sections. See drawings NFN 138E and NFN 139E.

**INSTALLATION INSTRUCTIONS FOR NOFIRNO®  
BLIND TRANSIT SEALING SYSTEM IN DECKS**

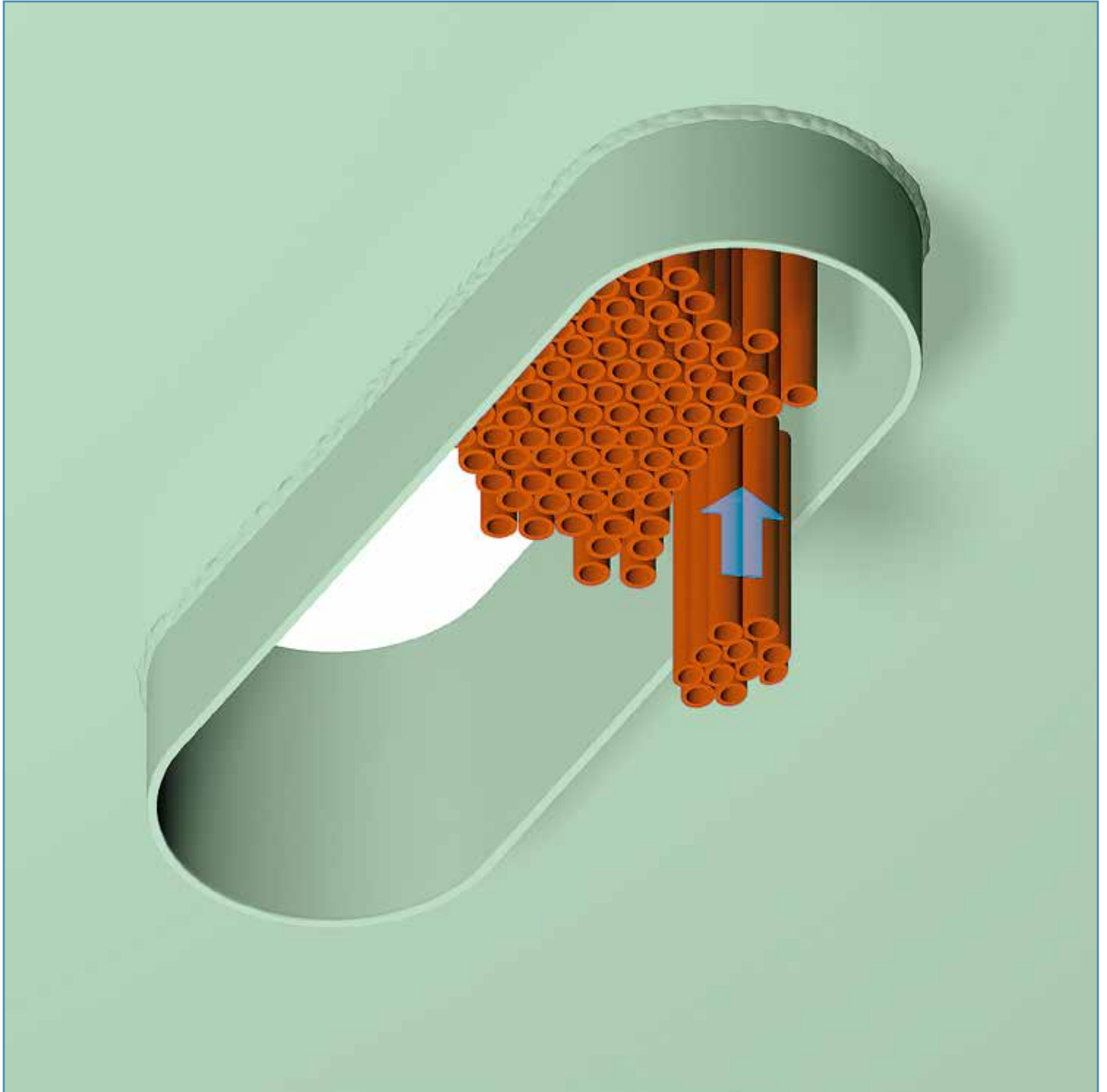

The multi-filler sleeves are very useful, especially for sealing deck penetrations. By making use of the NOFIRNO® multi-filler sleeves, sets and bundles can be made to ensure tight fitting inside the transit. Inserting fitting sets or bundles of multi-sleeves will ensure that sleeves won't fall out of the conduit frame.

**INSTALLATION INSTRUCTIONS FOR NOFIRNO®  
BLIND TRANSIT SEALING SYSTEM IN DECKS**



The NOFIRNO® sealant can be applied overhead for deck/floor transits without dripping or sagging. After application of the sealant, the NOFIRNO® sealant is pressed tightly with a cloth sprayed with water. This prevents the sealant from sticking to the cloth. The surface can be smoothed by hand. Just wet the hands thoroughly with water. No dirty hands when working with NOFIRNO® and a very neat surface is the result.

Use protective gloves when working with NOFIRNO® sealant. Please refer to the Safety Data Sheet for more information.

## INSTALLATION INSTRUCTIONS FOR NOFIRNO® BLIND TRANSIT SEALING SYSTEM

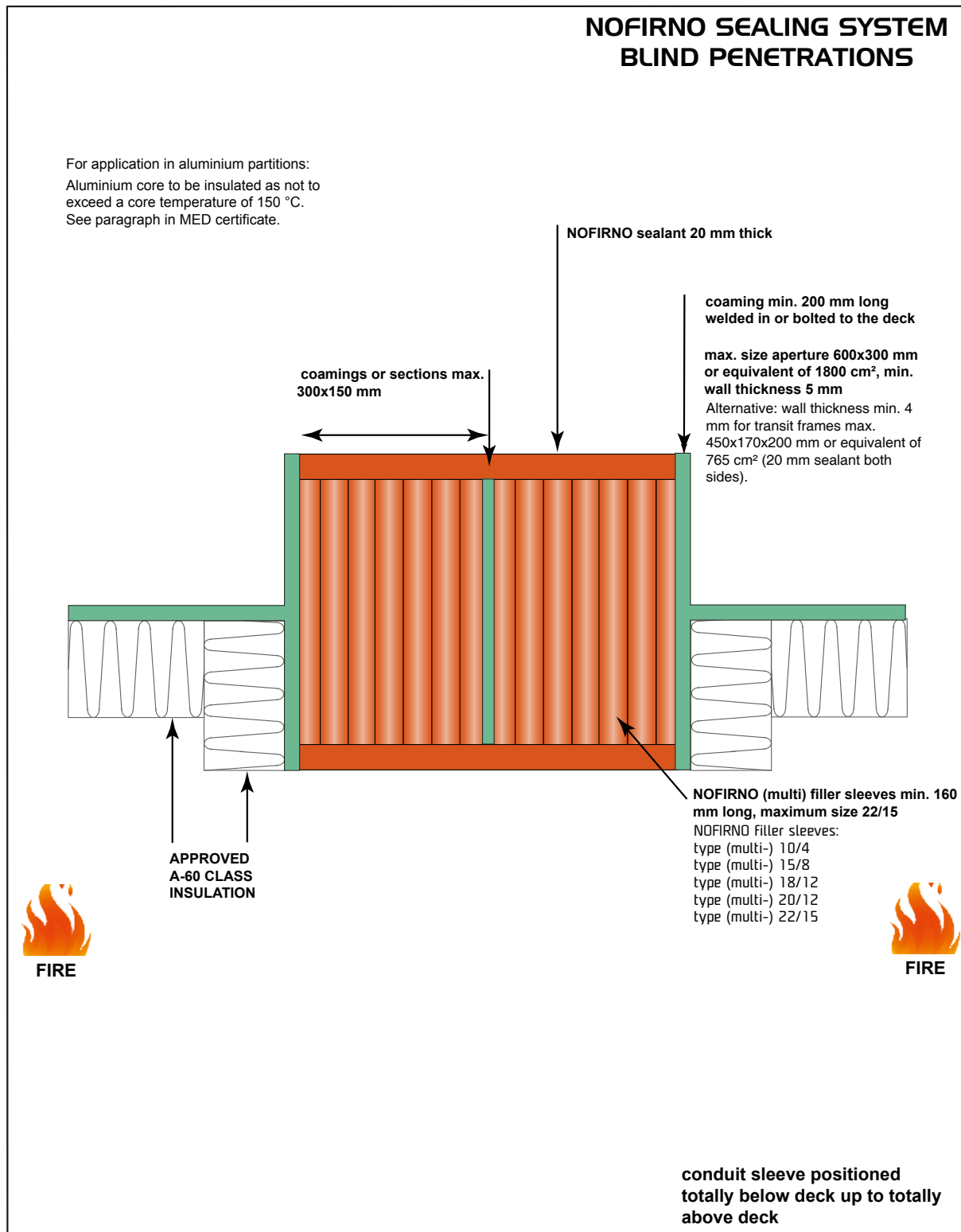

Description: NOFIRNO sealing system for A60 class decks

Mat.: NOFIRNO sleeves/sealant

Ref.: JAB

Date:

14-10-2019

Scale:

*No part of this document may be reproduced by photocopy, print, microfilm or any means without the written permission of BEELE Engineering bv of The Netherlands*

Rev. 2

02-04-2020

Rev. 3

15-10-2020

**NFN 139E**

## INSTALLATION INSTRUCTIONS FOR NOFIRNO® (MULTI-) PIPE TRANSIT SEALING SYSTEM



Certificate of  
EC Type-examination (Module B)  
**192130009/AA/04**  
**Product Category: MED/3.26b**  
**USCG Approval No: 164.138/EC0560**

|               |   |                                       |                 |
|---------------|---|---------------------------------------|-----------------|
| <b>Issued</b> | 17 May 2021                             | <b>Date of expiration of validity</b> | 31 October 2024 |
| <b>Page</b>   | 1 of 52<br>Certificate has four Annexes | <b>Last date of placement</b>         | 31 October 2024 |

With respect to Marine Equipment Directive 2014/90/EU and the implementing Regulation (EU) 2020/1170, Kiwa Telefication Notified Body 0560 declares that the equipment:

|                      |                               |
|----------------------|-------------------------------|
| Product description: | <b>NOFIRNO sealing system</b> |
| Trademark:           | <b>NOFIRNO</b>                |
| Type designation:    | <b>NOFIRNO</b>                |
| Variants:            | <b>See Annex 3</b>            |

|               |                          |
|---------------|--------------------------|
| Manufacturer: | <b>BEELE ENGINEERING</b> |
| Address:      | <b>Beunkdijk 11</b>      |
| City:         | <b>7122 NZ AALTEN</b>    |
| Country:      | <b>Netherlands</b>       |

Complies with the international instruments and test standards as listed in the Annex.  
This certificate is granted to:

|          |                          |
|----------|--------------------------|
| Name:    | <b>BEELE ENGINEERING</b> |
| Address: | <b>Beunkdijk 11</b>      |
| City:    | <b>7122 NZ AALTEN</b>    |
| Country: | <b>Netherlands</b>       |

CERTIFICATE

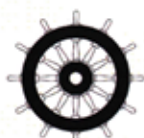

0560



Gözde Tuzcu  
Assessor



**Kiwa Telefication**  
Wilmsdorp 50  
7327 AC APELDOORN  
The Netherlands  
Tel: +31 88 998 3600  
[www.telefication.com](http://www.telefication.com)

Chamber of commerce  
51565536

# STATE-OF-THE ART METALLIC & PLASTIC PIPE SEALING SYSTEMS

**NOFIRNO**

**slipsil**  
**slipsil**  
**XL-120**

**DYNATITE**

**CRUSHER**

## NOFIRNO®

- Approved for harshest fire ratings for pipe transits (A, H and Jet Fire class).
- Allows axial and radial movement of the ducted pipe. High pressure ratings - designed for gas and/or watertight penetrations.
- Prevents corrosion inside the penetration.
- NOFIRNO® rubber sleeves and sealant will remain stable and not be consumed by fire.
- **Breakthrough - MULTI-ALL-MIX® SYSTEM**
- Approved for any combination of cable and/or metallic, GRP or plastic pipes!

## SLIPSIL®

- Designed to provide fire safe, gas and watertight seals for pipe penetrations.
- For transits carrying single or multiple metal pipes with the same diameter (hydraulic and pneumatic lines).
- Installs in a couple of minutes. Lubricate and push - that is it!
- No bolting or other mechanical devices.
- Absorbs mechanical stresses, vibration and prevents galvanic corrosion problems.
- Wide temperature range: -60 °C up to +180 °C.
- **Proven - simple, shortest conduit length**
- The system of choice in shipyards worldwide for more than 30 years!

## DYNATITE®

- For applications where a high degree of (instantaneous) tightness is required.
- Dynamic sealing when a disaster occurs.
- Plugs are compressible and will return to their original shape after shock pressure.
- Easily withstands shock pressure loads of up to 15 bar (220 psi).
- Ideal solution for the columns of offshore rigs and collision bulkheads.
- **Breakthrough - dynamic compression**
- Based on high-tech rubber grade and engineered profiling, the DYNATITE® plugs can be substantially compressed and get tighter with excessive pressure.

## CRUSHER®

- Simple and effective system for all plastic pipe transits.
- RISE®/ULTRA C-FIT crushers squeeze and seal.
- RISE®/ULTRA wraps to be used for non-SLIPSIL® and oversized conduit sleeves.
- RISE®/ULTRA C-FIT crushers and wraps integrated in the NOFIRNO® sealing system.
- NOFIRNO® sealant adheres well to plastics: high degree of water tightness feasible.
- **Breakthrough - adhesion under fire load**
- RISE®/ULTRA compound forms an adhesive mass during fire exposure!
- Approved for a multiple mixture of all kinds of plastic pipes.

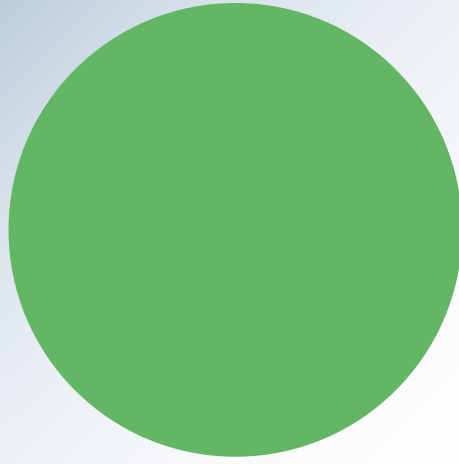

***WE CARE***

**BEELE ENGINEERING:  
A COMPANY DEDICATED  
TO SAFETY  
FOR OVER 45 YEARS**



**BEELE Engineering bv**  
Beunkdijk 11 - 7122 NZ AALTEN - THE NETHERLANDS  
Tel. +31 543 461629 - Fax +31 543 461786 - E-mail: [info@beele.com](mailto:info@beele.com)  
Websites: <https://www.beele.com>, [sealingvalley.com](https://sealingvalley.com) and [fissiccoating.com](https://fissiccoating.com)